

# VTD SERIES

## DC Voltage Transducers

VTD Series Voltage Transducers are high-performance transducers for sensing voltage in DC powered installations. Applicable for use on circuits to 600 VDC, VTD voltage transducers provide fully isolated 0–5 VDC, 0–10 VDC, and 4–20 mA outputs proportional to rated nominal voltage in DC circuits. Housed in a slim, compact, easy-to-install DIN rail mounted case, the VTD Series comes in a variety of nominal voltages.



### Voltage Transducer Applications

#### Voltage Monitoring

- Detect below normal or “brown out” voltage conditions; protect against possible motor overheating.
- Identify conductor loss conditions by detecting voltage reduction in one motor lead.
- Monitor over voltage conditions associated with regenerative voltage to help in diagnosing/avoiding motor drive issues.
- Detect voltage conditions that may cause stress or damage to soft starter components (SCRs).

DC Voltage Transducer Control

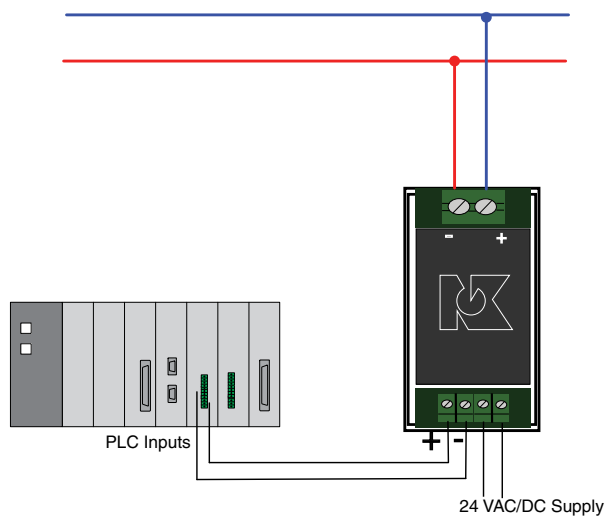

For additional Application Examples, go to [www.nktechnologies.com/applications](http://www.nktechnologies.com/applications)

### Voltage Transducer Features

#### Accurate Output

- Several ranges available for your application, from 0–15 VDC to 0–600 VDC.

#### Standard Current and Voltage Sensor Outputs

- Industry standard outputs makes use with existing controllers, data loggers and SCADA equipment easy and reliable.

#### Input/Output Isolation

- Input and Output circuitry electrically isolated for improved safety of use.

#### Compact DIN Rail Mounted Case\*

- Space saving 35 mm wide enclosure mounts quickly for an attractive installation.

#### UL/cUL and CE Approved

- Accepted worldwide.

\*For information on the DIN rail accessories kit, see page 128.

### Voltage Transducer Dimensions

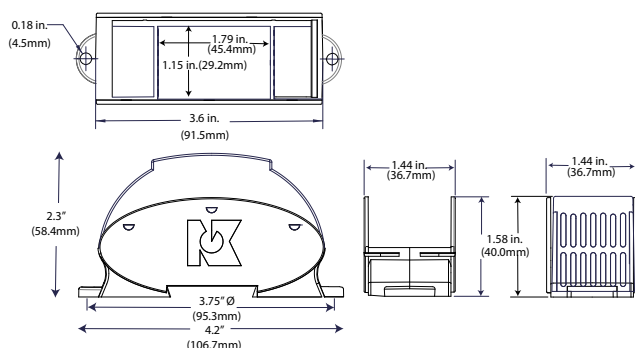

### Voltage Transducer Connections

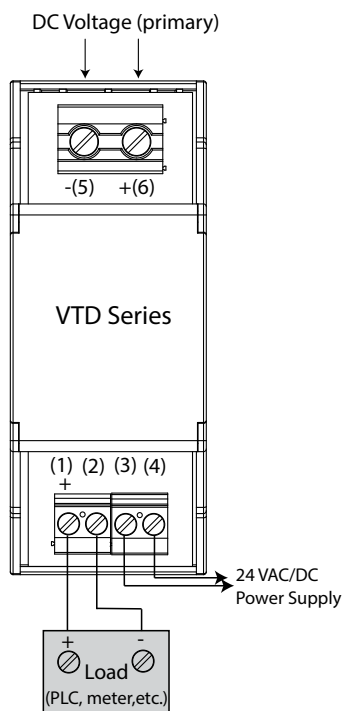

### Voltage Transducer Specifications



<b>Power Supply</b>	24 VAC/DC (20–45 DC, 22–38 VAC)
<b>Input Range</b>	15 V, 25 V, 50 V, 150 V, 300 V, 600 VDC
<b>Power Consumption</b>	<2 VA
<b>Output</b>	<ul style="list-style-type: none"> <li>• 4–20 mA (capped at 24 mA max.)</li> <li>• 0–5 VDC (capped at 5.75 VDC),</li> <li>• 0–10 VDC (capped at 11.5 VDC)</li> </ul>
<b>Output Loading</b>	<ul style="list-style-type: none"> <li>• 4–20 mA output: &lt;500 Ω</li> <li>• 0–5/10 VDC output: &gt;10 KΩ</li> </ul>
<b>Response Time</b>	250 ms (90% step change)
<b>Accuracy</b>	<1%
<b>Isolation Voltage</b>	UL listed to 1270 VAC, tested to 5 KV
<b>Frequency Range</b>	DC
<b>Case</b>	UL94 V-0 Flammability Rated
<b>Mounting</b>	DIN rail or panel mounting
<b>EMC/Immunity</b>	EN50081-1, EN50082-2
<b>Ripple</b>	<1% (peak to peak)
<b>Environmental</b>	-4 to 122°F (-20 to 50°C) 0–95% RH, non-condensing
<b>Listings</b>	UL/cUL, CE

### Voltage Transducer Ordering Information

Sample Model Number: VTD1-420-24U-DIN  
 DC voltage transducer with 25 V range, standard 4–20 mA proportional output; 24 V externally powered with a DIN rail compatible case.



(1) Nominal Range	
0	0–15 VDC
1	0–25 VDC
2	0–50 VDC
3	0–150 VDC
4	0–300 VDC
5	0–600 VDC
(2) Output Type	
005	0–5 VDC
010	0–10 VDC
420	4–20 mA
(3) Supply Voltage	
24U	24 VAC/DC external power supply
(4) Mounting	
DIN	DIN rail compatible

**OEMs** Test & Evaluation Units for OEMs  
 Free program expedites evaluation process. See page 3 for details.

