

DS1 SERIES

DC Current Sensing Switches

The DS1 Series Current Sensing Switches are designed to trip a solid-state contact when there is DC current through the sensor window. The sensor can be used to interlock two operations for safety. When one load is energized, the contact will keep another from also energizing. The power supply voltage and the controlled circuit voltage can be derived from a single source or separate sources. The monitored circuit can be any DC voltage and any amount of current as long as the conductor will pass through the window. The monitored circuit is completely isolated from the control circuit. If there is 3/4 of one amp through the aperture, the output will change state.



Current Sensing Switch Applications

- As a safety interlock, it is a non-intrusive method to keep personnel safe.
- Alarm contact when a load is operating or when it is not energized.
- Detect PV system leakage by monitoring the earth bond conductor.
- Use the contact to turn on a lighting circuit when a load is energized.
- Instant indication of equipment status.

Current Sensing Switch Features

Compact, One-piece Design

- Fits in easily amongst motor starters and power supplies in crowded control cabinets.

Input Isolation

- Safer than shunt/relay combinations.

Unique Power Supply Connection

- Sensor power and switched load share a common point making installation easy.

Built-in Mounting Feet

- Simple, two-screw installation allows for secure mounting.

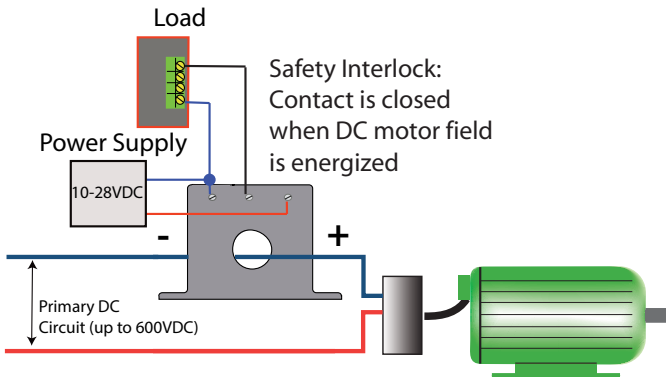

For additional Application Examples, go to www.nktechnologies.com/applications

OEMs Test & Evaluation Units for OEMs
Free program expedites evaluation process. See page 1 for details.

Current Sensing Switch Dimensions

FF Case

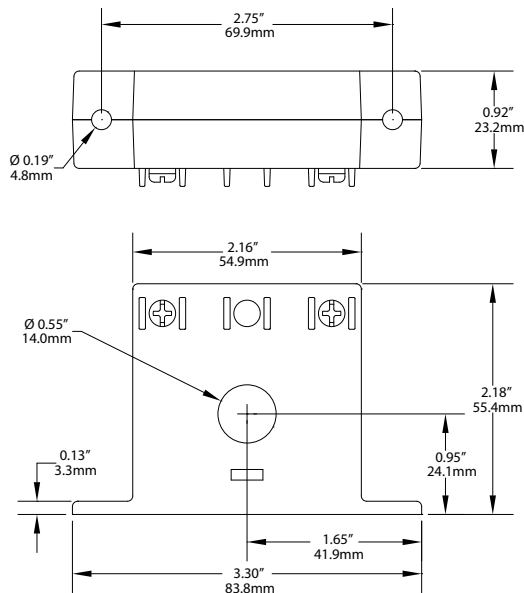

Current Sensing Switch Connections

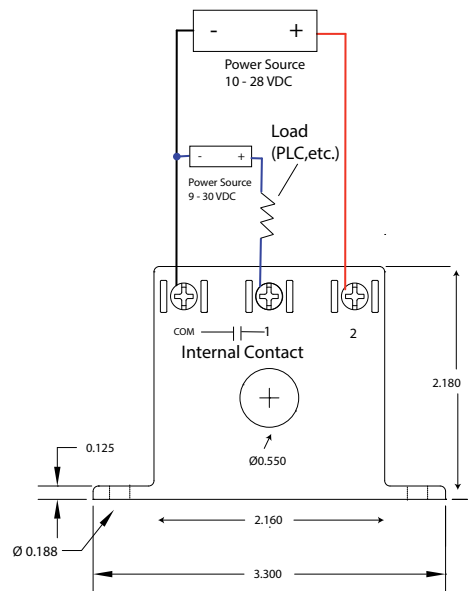

Notes:
 Zinc plated screw terminals solid-core case.
 Split core versions are not available.
 12–22 AWG solid or stranded.

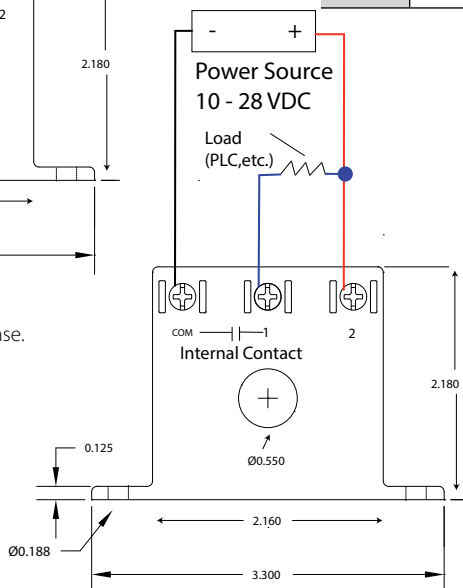

Current Sensing Switch Specifications

Power Supply	10–28 VDC
Power Consumption	<2 VA
Setpoint Range	0.75 A (factory set)
Output Description	Isolated solid-state relay
Off-state Leakage	<1 μ A
Response Time	600 ms max.
Time Delay	None, after 5 seconds when first powered up
Output Rating	1 A up to 30 VDC
Hysteresis	5%
Overload	500 A continuous, 1000 A @ 5 sec.
Isolation Voltage	Tested to 3 KV
Frequency Range	DC
Case	UL94 V-0 Flammability Rated
Environmental	-4 to 122°F (-20 to 50°C) 0–95% RH, non-condensing

Current Sensing Switch Ordering Information

Sample Model Number: DS1-NODC-FF

Solid-core DC current sensing switch closes with 0.75 ADC, normally open, front terminal solid-core case. (DIN rail adapters are included)

DS ⁽¹⁾ 1 - ⁽²⁾ N O D C - ⁽³⁾ F F

(1) Range

1	0.75 ADC
---	----------

(2) Output Type

NODC	Normally Open (1 A @ 28 VDC)
------	------------------------------

(3) Case Style

FF	Solid-core, Front Terminals
----	-----------------------------

