

For the electronic measurement of current: DC, AC, pulsed..., with galvanic separation between the primary and the secondary circuit.



## Features

- Closed loop (compensated) current transducer using an extremely accurate zero flux detector
- 9-pin D-Sub male secondary connector
- Status signal to indicate the transducer state
- LED indicator confirms normal operation
- Metal housing to improve immunity to EMC & power dissipation
- Operating temperature  $-40\text{ }^{\circ}\text{C}$  to  $85\text{ }^{\circ}\text{C}$
- Large aperture  $\varnothing 38\text{ mm}$  for cables and busbars.

## Advantages

- Very high accuracy
- Excellent linearity
- Extremely low temperature drift
- Wide frequency bandwidth
- High immunity to external fields
- No insertion losses
- Very low noise on output signal
- Low noise feedback to primary conductor.

## Applications

- Feedback element in high performance gradient amplifiers for MRI
- Feedback element in high-precision, high-stability power supplies
- Calibration unit
- Feedback element for Power Meter (e.g. EV Test Benches)
- Medical equipment.

## Standards

IEC 61010-1

EMC:

- IEC 61000-6-2: 2016
- IEC 61000-6-3: 2006 + A1 (2010)

Safety:

- IEC 61010-2-030: 2017
- IEC 61010-1:2010/AMD1: 2016.

## Application Domains

- Industrial
- Laboratory
- Medical.

## Safety



Caution

If the device is used in a way that is not specified by the manufacturer, the protection provided by the device may be compromised. Always inspect the electronics unit and connecting cable before using this product and do not use it if damaged. Mounting assembly shall guarantee the maximum primary conductor temperature, fulfill clearance and creepage distance, minimize electric and magnetic coupling, and unless otherwise specified can be mounted in any orientation.



Caution, risk of electrical shock

This transducer must be used in limited-energy secondary circuits SELV according to IEC 61010-1, in electric/electronic equipment with respect to applicable standards and safety requirements in accordance with the manufacturer's operating specifications.

Use caution during installation and use of this product; certain parts of the module can carry hazardous voltages and high currents (e.g. primary conductor).

Ignoring this warning can lead to injury and or/or cause serious damage.

De-energize all circuits and hazardous live parts before installing the product.

All installations, servicing operations and use must be carried out by trained and qualified personnel practicing applicable safety precautions.

This transducer is a built-in device, no maintenance required; cleaning by dry compressed air is authorized.

This transducer is a build-in device, whose hazardous live parts must be inaccessible after installation.

This transducer must be mounted in a suitable end-enclosure.

Besides make sure to have a distance of minimum 30 mm between the primary conductor (return bar) and the transducer and other neighboring components.

Main supply must be able to be disconnected.

Always inspect the current transducer for damage before using this product.

Never connect or disconnect the external power supply while the primary circuit is connected to live parts.

Never connect the output to any equipment with a common mode voltage to earth greater than 30 V.

Always wear protective clothing and gloves if hazardous live parts are present in the installation where the measurement is carried out.

Safe and trouble-free operation of this transducer can only be guaranteed if transport, storage and installation are carried out correctly and are carried out with care.

The current transducer shall not be opened or modified.

If not working, the current transducer shall be replaced by an equivalent device.



ESD susceptibility

The product is susceptible to ESD damage if the secondary (D-Sub) connector pins are touched without being properly grounded.



Caution, hot surface

Power supply cable must support a temperature of 100 °C at least and it must be fixed in a way to not be in contact with the product housing and primary conductor.

Do not dispose of this product as unsorted municipal waste. Contact a qualified recycler for disposal.

## Absolute maximum ratings

Parameter	Symbol	Unit	Value
Maximum supply voltage (working) (-40 ... 85 °C)	$\pm U_{C\ max}$	V	16.5
Maximum primary conductor temperature	$T_{B\ max}$	°C	100

Absolute maximum ratings apply at 25 °C unless otherwise noted.  
 Stresses above these ratings may cause permanent damage.  
 Exposure to absolute maximum ratings for extended periods may degrade reliability.

## Environmental and mechanical characteristics

Parameter	Symbol	Unit	Min	Typ	Max	Comment
Ambient operating temperature	$T_A$	°C	-40		85	
Ambient storage temperature	$T_{A\ st}$	°C	-40		85	
Relative humidity	$RH$	%	20		80	Non condensing
Dimensions						See drawing on <a href="#">page 9</a>
Mass	$m$	kg		1.3		
Altitude <sup>1)</sup>		m			2000	
Environmental conditions						Indoor
Cooling conditions						Natural convection
Degree of protection against mechanical impacts				IK 08		With busbar completely filling the aperture

## Insulation coordination

Parameter	Symbol	Unit	Value	Comment
RMS voltage for AC insulation test, 50 Hz, 1 min	$U_d$	kV	4.2	Between primary and secondary + shield
Impulse withstand voltage 1.2/50 µs	$U_{Ni}$	kV	8	
Clearance (pri. - sec.) <sup>2)</sup>	$d_{Cl}$	mm	11.5	Shortest distance through air
Creepage distance (pri. - sec.) <sup>2)</sup>	$d_{Cp}$	mm	11.9	Shortest path along device body
Comparative tracking index	$CTI$		600	
Rated insulation RMS voltage	$U_{Nm}$	V	1000	Basic insulation according to IEC 61010-1 CAT III, PD2
Rated insulation RMS voltage			1000	Reinforced insulation according to IEC 61010-1 CAT II, PD2

- Notes:** <sup>1)</sup> Insulation coordination at 2000 m  
<sup>2)</sup> Mating connector not included in this calculation, which can degrade Clearance and Creepage distance depending on the material and dimensions of said mating connector.

**Electrical data**

At  $T_A = 25\text{ °C}$ ,  $\pm U_C = \pm 15\text{ V DC}$ , unless otherwise noted (see Min, Max, typ, definition paragraph in [page 5](#)).

Parameter	Symbol	Unit	Min	Typ	Max	Comment
Primary nominal DC current (continuous)	$I_{PNDC}$	A	-500		500	$T_A = -40 \dots 85\text{ °C}$
Primary nominal AC RMS current (continuous)	$I_{PNAC}$	A	-500		500	$T_A = -40 \dots 85\text{ °C}$ ;
Peak primary current, measuring range	$\hat{I}_{PM}$	A	-800		800	With $\pm U_C = 14.25\text{ V}$ , $T_A = -40 \dots 85\text{ °C}$ , $R_M = 2.5\text{ }\Omega$ ;
Measuring resistance	$R_M$	$\Omega$	0		2.5	for other values see curves <a href="#">page 7</a>
Secondary nominal RMS current	$I_{SN}$	A	$\approx -0.667$		$\approx 0.667$	
Maximum withstand primary peak current <sup>1)</sup>	$\hat{I}_{Pmax}$	kA	-5		5	Non repetitive pulse 100 ms
Resistance of secondary winding	$R_S$	$\Omega$		6.5		@ $25\text{ °C}$
Number of secondary turns	$N_S$			750		
DC supply voltage ==	$+U_C$	V	14.25	15	15.75	
DC supply voltage ==	$-U_C$	V	-14.25	-15	-15.75	
DC current consumption ==	$+I_C$	A		0.12		@ $I_P = 0$
				0.79		@ $I_P = I_{PN}$
				1.19		@ $I_P = I_{PM}$
DC current consumption ==	$-I_C$	A		0.07		@ $I_P = 0$
				0.74		@ $I_P = I_{PN}$
				1.14		@ $I_P = I_{PM}$
RMS noise current 0 ... 10 Hz referred to primary <sup>2)</sup>	$I_{no}$	ppm		0.05	0.1	
RMS noise current 0 ... 10 kHz referred to primary <sup>2)</sup>				1.5	4	
RMS noise current 0 ... 100 kHz referred to primary <sup>2)</sup>				3.5	10	
Peak-to-peak noise current <sup>2)</sup>	$I_{no pp}$	ppm		18	34	
Fluxgate excitation frequency		kHz		15.625		$T_A = -40 \dots 85\text{ °C}$
Electrical offset current referred to primary <sup>2)</sup>	$I_{OE}$	ppm	-10		10	@ $25\text{ °C}$
Temperature coefficient of $I_{OE}$ referred to primary <sup>2)</sup>	$TCI_{OE}$	ppm/K	-0.2	0.05	0.2	$T_A = -40 \dots 85\text{ °C}$
Offset stability <sup>2)</sup>		ppm/month	-0.2		0.2	
Linearity error <sup>2)</sup>	$\varepsilon_L$	ppm	-1.5	0.8	1.5	
			-3	1	3	$T_A = -40 \dots 85\text{ °C}$
Delay time to 10 % of the final output value for $I_{PN}$ step	$t_{D10}$	$\mu\text{s}$			< 1	
Delay time to 90 % of the final output value for $I_{PN}$ step	$t_{D90}$	$\mu\text{s}$			< 1	$di/dt$ of 100 A/ $\mu\text{s}$
Frequency bandwidth ( $\pm 1\text{ dB}$ )	$BW$	kHz		400		Small-signal bandwidth, 1.5 % of $I_{PN}$
Frequency bandwidth ( $\pm 3\text{ dB}$ )				520		
Start-up time	$t_{start}$	s			< 15	$T_A = -40 \dots 85\text{ °C}$

**Notes:** <sup>1)</sup> Single pulse only, not AC. The transducer may require a few seconds to return to normal operation when autoreset system is running; <sup>2)</sup> All ppm figures refer to full-scale which corresponds to a secondary nominal RMS current.

### Definition of typical, minimum and maximum values

Minimum and maximum values for specified limiting and safety conditions have to be understood as such as well as values shown in “typical” graphs.

On the other hand, measured values are part of a statistical distribution that can be specified by an interval with upper and lower limits and a probability for measured values to lie within this interval.

Unless otherwise stated (e.g. “100 % tested”), the LEM definition for such intervals designated with “min” and “max” is that the probability for values of samples to lie in this interval is 99.73 %.

For a normal (Gaussian) distribution, this corresponds to an interval between -3 sigma and +3 sigma. If “typical” values are not obviously mean or average values, those values are defined to delimit intervals with a probability of 68.27 %, corresponding to an interval between -sigma and +sigma for a normal distribution.

Typical, maximal and minimal values are determined during the initial characterization of the product.

### Power supply and load

In order to reach the measuring range according to the maximum measuring resistor, be careful with the setup measurement when wires length are high. It means that:

- the wires resistance could be not negligible
- the voltage at the output of the DC power supply and the voltage at the transducer could be significantly different.

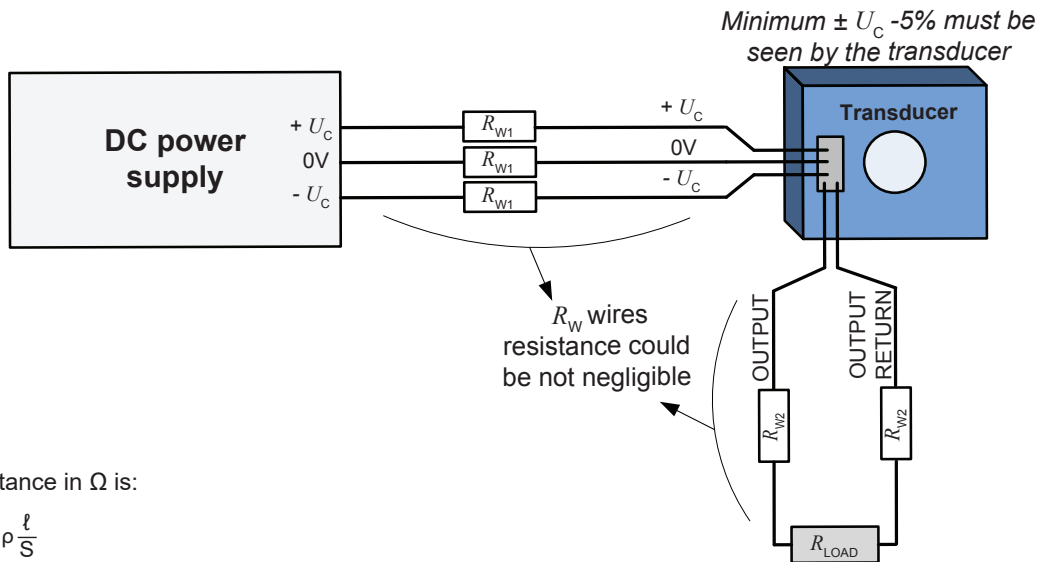

$R_w$  wire resistance in  $\Omega$  is:

$$R_w = \rho \frac{l}{S}$$

- S: Cross section of wire in  $m^2$
- l: Wire length in m
- $\rho$ : Resistivity of material in  $\Omega.m$

#### Total measuring resistance is:

$$R_M = R_L + 2 \times R_{W1} + 2 \times R_{W2}$$

If  $R_{W1} = R_{W2} = R_{WIRE}$  then  $R_M = R_L + 4 \times R_{WIRE}$

### Overload protection - Electrical specification - Status

The overload occurs when the primary current  $I_p$  exceeds a trip level such that the fluxgate detector becomes completely saturated and, consequently, the transducer will switch from normal operation to overload mode.

This trip level is guaranteed to be greater than  $I_{P_M}$  and its actual value depends on operating conditions such as temperature and measuring resistance.

When this happens, the transducer will automatically begin to sweep in order to lock on the primary current again.

The overload conditions will be:

- The secondary current  $I_s$  generated is a low frequency signal.
- The signal normal operation status (between pin 3 and 8 of the D-sub connector) switches to  $U+$  or  $\approx 0.7 V$ . See the status port wiring below.
- The green LED indicator (normal operation status) turns off.

The measuring can resume when the primary current returns in the measuring range between  $-I_{P_N}$  and  $+I_{P_N}$ . Then the signal normal operation status switches to GND and the green LED indicator (normal operation status) switches on.

### Status/Interlock port wiring

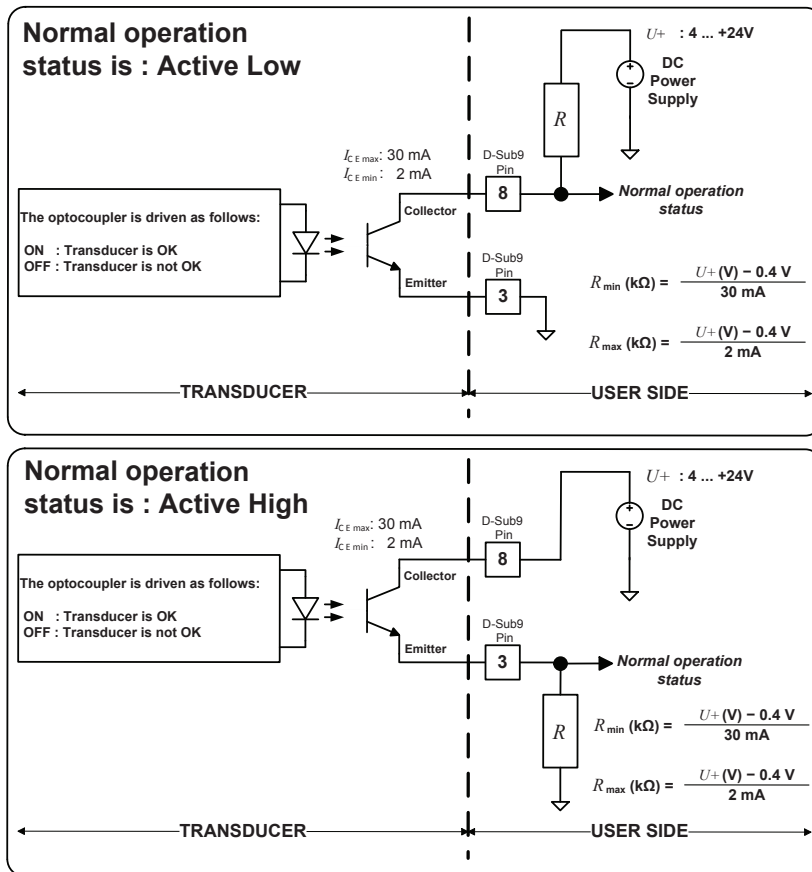

The following table shows how the normal operation status acts as below:

Status	Value	Description
Active Low	$\approx 0.7 V$	The transducer is OK (Normal operation)
	$U+$	The transducer is not OK (Overload mode or supply fault)
Active High	$U+$	The transducer is OK (Normal operation)
	$\approx 0.7 V$	The transducer is not OK (Overload mode or supply fault)

Maximum measuring resistance versus primary current and temperature

$\pm U_c = \pm 14.25\text{ V}$

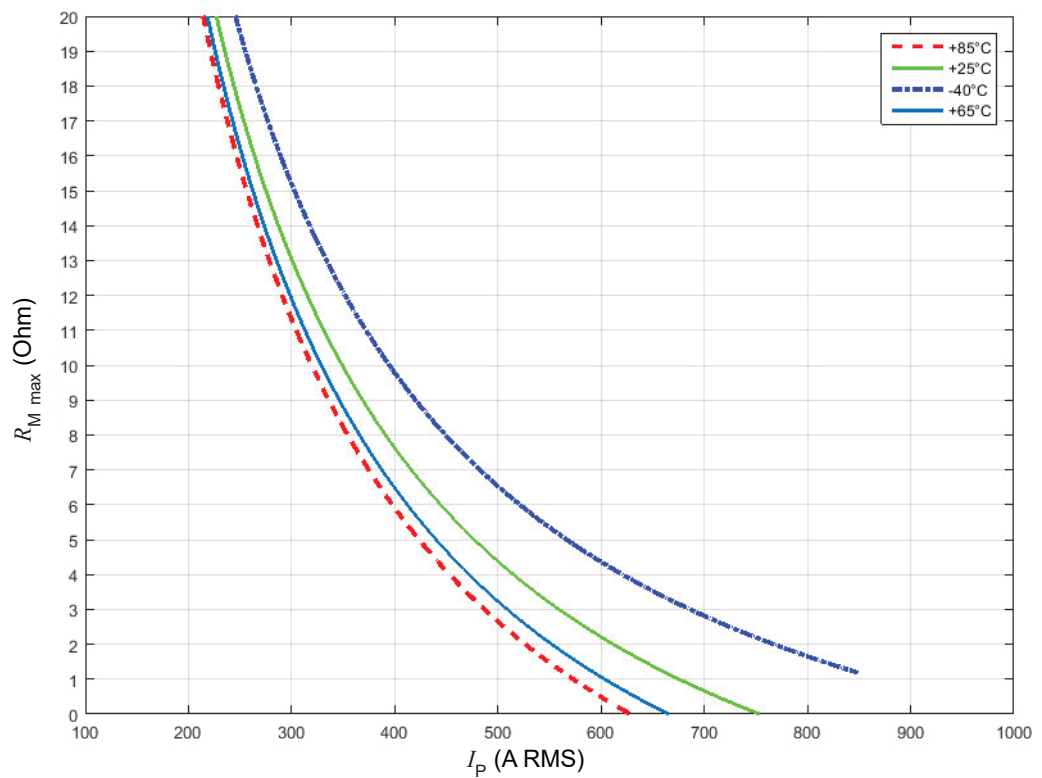
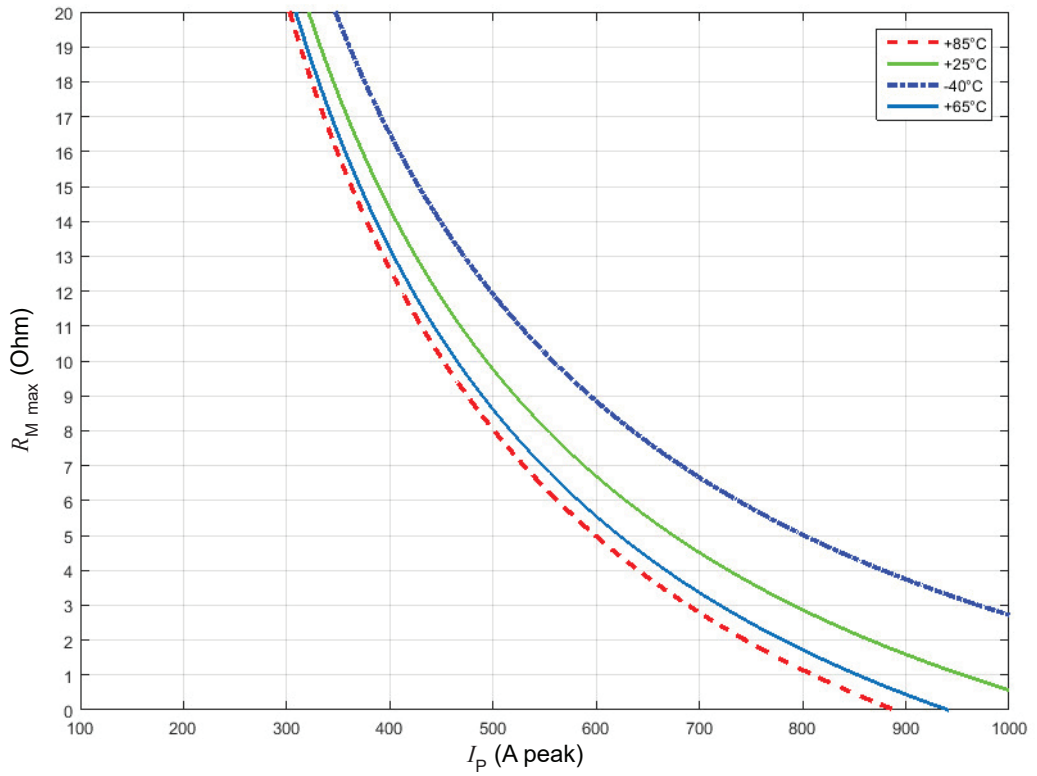

## Performance parameters definition

The schematic used to measure all electrical parameters is shown below:

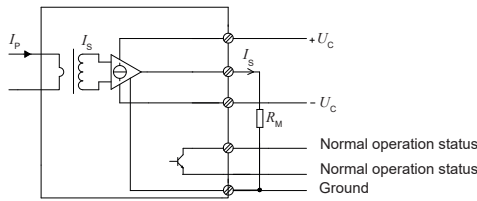

### Transducer simplified model

The static model of the transducer at temperature  $T_A$  is:

$$I_S = N_P/N_S \cdot I_P + \varepsilon$$

In which

$$\varepsilon = I_{OE} \text{ at } 25^\circ\text{C} + I_{OT}(T_A) + \varepsilon_L \cdot I_{PM} \cdot N_P/N_S$$

Where,

$$I_{OT}(T_A) = TCI_{OE} \cdot |T_A - 25^\circ\text{C}| \cdot I_{PM} \cdot N_P/N_S$$

- $I_S$  : secondary current (A)
- $N_P/N_S$  : turns ratio (1:  $N_S$ )
- $I_P$  : primary current (A)
- $I_{PM}$  : primary current, measuring range (A)
- $T_A$  : ambient operating temperature ( $^\circ\text{C}$ )
- $I_{OE}$  : electrical offset current (A)
- $I_{OT}$  : temperature variation of  $I_{OE}$  at  $T_A$  (A)
- $\varepsilon_L$  : linearity error

This is the absolute maximum error. As all errors are independent, a more realistic way to calculate the error would be to use the following formula:

$$\varepsilon = \sqrt{\sum_{i=1}^N \varepsilon_i^2}$$

### Linearity

To measure linearity, the primary current (DC) is cycled from 0 to  $I_{PM}$ , then to  $-I_{PM}$  and back to 0. The linearity error  $\varepsilon_L$  is the maximum positive or negative difference between the measured points and the linear regression line, expressed in parts per million (ppm) of full-scale which corresponds to the maximum measured value.

### Electrical offset

The electrical offset current  $I_{OE}$  is the residual output current when the input current is zero.

The temperature variation  $I_{OT}$  of the electrical offset current  $I_{OE}$  is the variation of the electrical offset from  $25^\circ\text{C}$  to the considered temperature.

### Delay times

The delay time  $t_{D10}$  @ 10 % and the delay time  $t_{D90}$  @ 90 % with respect to the primary are shown in the next figure.

Both slightly depend on the primary current  $di/dt$ . They are measured at nominal current.

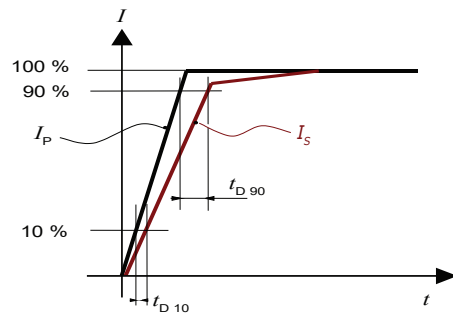

$t_{D10}$  (delay time @ 10 %) and  $t_{D90}$  (delay time @ 90 %)

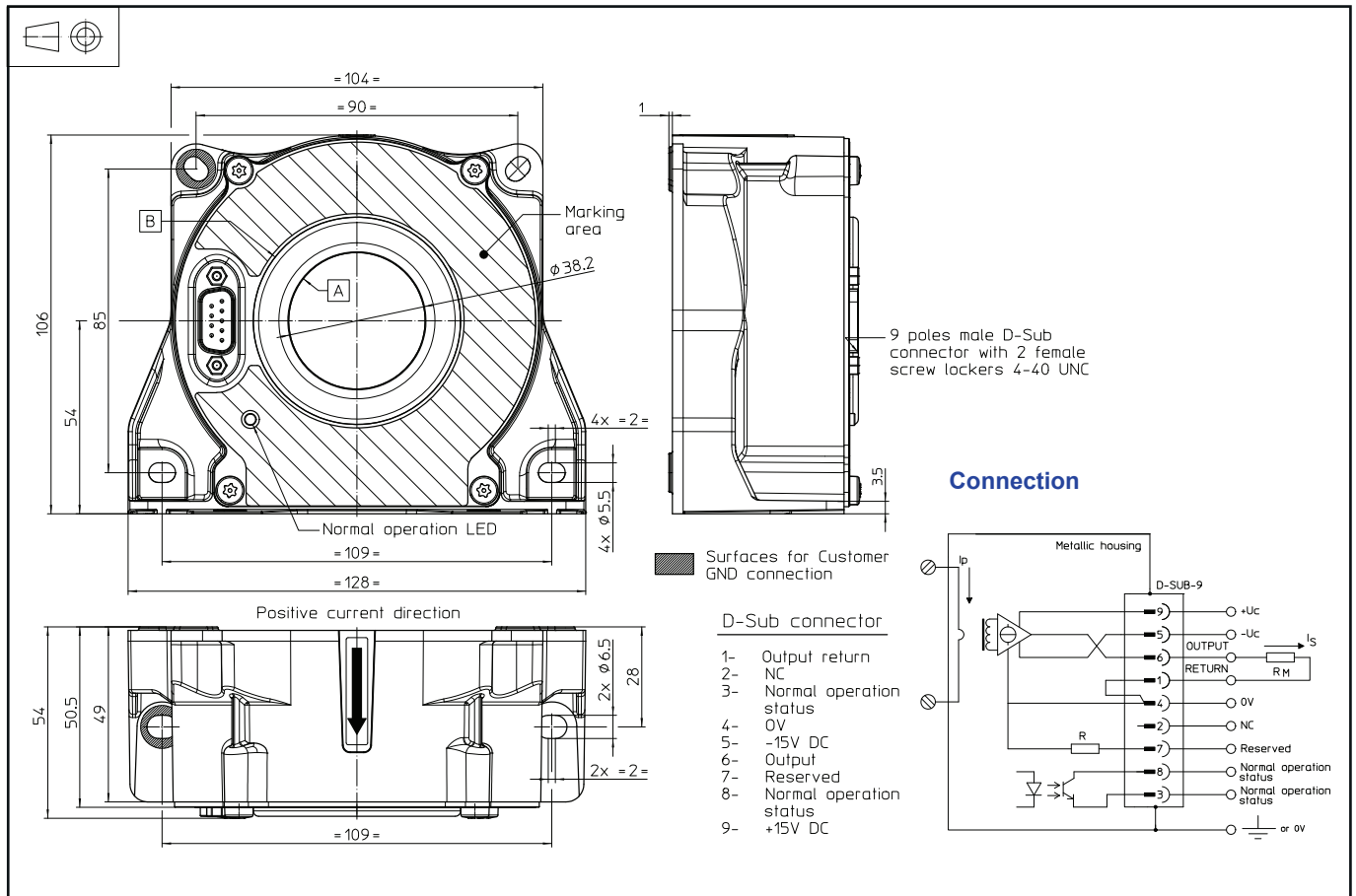

**Dimensions (in mm)**

**Connection**

- Normal operation status (Pins 3 and 8)  
Normal operation means:
  - $\pm 15\text{ V}$  ( $\pm U_c$ ) present
  - 0 V on D-Sub has to be tied
  - zero detector is working
  - compensation current  $\leq I_{PM\text{ DC}}$
  - green LED indicator switches on.
- Direct current = (DC)

**Mechanical characteristics**

- General tolerance  $\pm 0.5\text{ mm}$
- Transducer fastening
  - Horizontal mounting
    - 4 slotted holes  $\phi 5.5\text{ mm}$
    - 4 M5 steel screws
  - Vertical mounting
    - 2 slotted holes  $\phi 6.5\text{ mm}$
    - 2 M6 steel screws
- Recommended fastening torque
  - Horizontal mounting: 3.7 N·m
  - Vertical mounting: 4.4 N·m
- Recommended fastening torque: 4.4 N·m
- Connection of secondary: on D-Sub-9, UNC 4-40
- Manual tightening until full stop

**Remarks**

- $I_s$  is positive when  $I_p$  flows in the direction of the arrow.
- We recommend that a shielded output cable and plug are used to ensure the maximum immunity against electrostatic fields.
- Temperature of the primary conductor should not exceed  $100\text{ }^\circ\text{C}$ .
- We recommend to fix the potential of the housing to the ground or 0 V (on indicated surfaces).
- Installation of the transducer must be done unless otherwise specified on the datasheet, according to LEM Transducer Generic Mounting Rules. Please refer to LEM document N°ANE120504 available on our Web site: <https://www.lem.com/en/file/3137/download>.
- All mounting recommendations are given for a standard mounting. Screws with flat and spring washers.