

Current Transducer HAR 1000-S

For the electronic measurement of currents: DC, AC, pulsed..., with galvanic separation between the primary circuit and the secondary circuit.



$$I_{PN} = \pm 1000 \text{ A}$$

$$V_{out} = \pm 5 \text{ V}$$

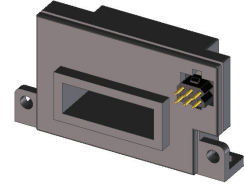

Electrical data

I_{PN}	Primary nominal RMS current	± 1000	A
I_{PM}	Primary current, measuring range @ $U_C = @ \pm 15 \text{ V}$	± 2500	A
R_{INS}	Insulation resistance @ 500 V DC	> 500	M Ω
V_{out}	Output voltage (Analog) @ $\pm I_{PN}$, $R_L = 10 \text{ k}\Omega$, $T_A = 25 \text{ }^\circ\text{C} \pm 5$	± 5	V
R_L	Load resistance	≥ 10	k Ω
R_{out}	Output internal resistance	< 100	Ω
U_C	Supply voltage ($\pm 5 \%$)	± 15	V
I_C	Current consumption	$< \pm 20 + I_S$	mA

Accuracy - Dynamic performance data

X	Accuracy ¹⁾ @ I_{PN} , $T_A = 25 \text{ }^\circ\text{C}$, $U_C = \pm 15 \text{ V}$, $R_L = 10 \text{ k}\Omega$	$< \pm 0.5$	% of I_{PN}
ϵ_L	Linearity error (0 ... $\pm I_{PN}$)	$< \pm 0.5$	% of I_{PN}
V_O	Offset voltage @ $I_p = 0$, $T_A = 25 \text{ }^\circ\text{C}$	$< \pm 20$	mV
V_{OH}	Hysteresis offset voltage @ $I_p = 0$ and specified R_M , after an excursion of $1 \times I_{PN}$	$< \pm 15$	mV
V_{OT}	Temperature variation of V_O (between $-40 \text{ }^\circ\text{C}$... $+70 \text{ }^\circ\text{C}$)	$< \pm 50$	mV
$V_{out T}$	Temperature variation of V_{out} (between $-40 \text{ }^\circ\text{C}$... $+70 \text{ }^\circ\text{C}$)	$< \pm 5.5$	mV
t_r	Step response time to 90 % of I_{PN}	≤ 5	μs
BW	Frequency bandwidth (-3 dB)	DC ... 10	kHz

General data

T_A	Ambient operating temperature	$-40 \dots +70$	$^\circ\text{C}$
T_S	Ambient storage temperature	$-40 \dots +85$	$^\circ\text{C}$
m	Mass	400	g
	Standard(s)	EN 50155: 2007 ²⁾	

Notes: ¹⁾ Accuracy data exclude the electrical offset.

²⁾ Deviation of the offset during the test IEC 61000-4-3 between 150 to 300 MHz.

Features

- Closed loop (compensated) current transducer using the Hall effect
- Galvanic separation between primary and secondary circuit
- Insulation voltage 7000 V
- Extended measuring range
- Insulating plastic case recognized according to UL 94-V0.

Advantages

- Excellent accuracy
- Very good linearity
- Low temperature drift
- Optimized response time
- Wide frequency bandwidth
- No insertion losses
- High immunity to external interference
- Current overload capability.

Applications

- AC variable speed drives and servo motor drives
- Static converters for DC motor drives
- Battery supplied applications
- Uninterruptible Power Supplies (UPS)
- Switched Mode Power Supplies (SMPS)
- Power supplies for welding applications.

Application domain

- Industrial.

Current Transducer HAR 1000-S

Insulation coordination

U_d	RMS voltage for AC insulation test, 50 Hz, 1 min	≥ 7	kV
\hat{U}_w	Impulse withstand voltage 1.2/50 μ s	≥ 3.6 Min	kV
d_{cp}	Creepage distance	≥ 26	mm
d_{cl}	Clearance	≥ 19	mm
CTI	Comparative tracking index (group IIIa)	275	

Applications examples

According to EN 50178 and IEC 61010-1 standards and following conditions:

- Over voltage category OV 3
- Pollution degree PD2
- Non-uniform field

	EN 50178	IEC 61010-1
$d_{cp}, d_{cl}, \hat{U}_w$	Rated insulation voltage	Nominal voltage
Basic insulation	2500 V	> 1000 V
Reinforced insulation	1000 V	> 1000 V

Safety

This transducer must be used in limited-energy secondary circuits according to IEC 61010-1.



This transducer must be used in electric/electronic equipment with respect to applicable standards and safety requirements in accordance with the manufacturer's operating instructions.



Caution, risk of electrical shock

When operating the transducer, certain parts of the module can carry hazardous voltage (e.g. primary busbar, power supply). Ignoring this warning can lead to injury and/or cause serious damage.

This transducer is a build-in device, whose conducting parts must be inaccessible after installation. A protective housing or additional shield could be used. Main supply must be able to be disconnected.

Dimensions HAR 1000-S (in mm)

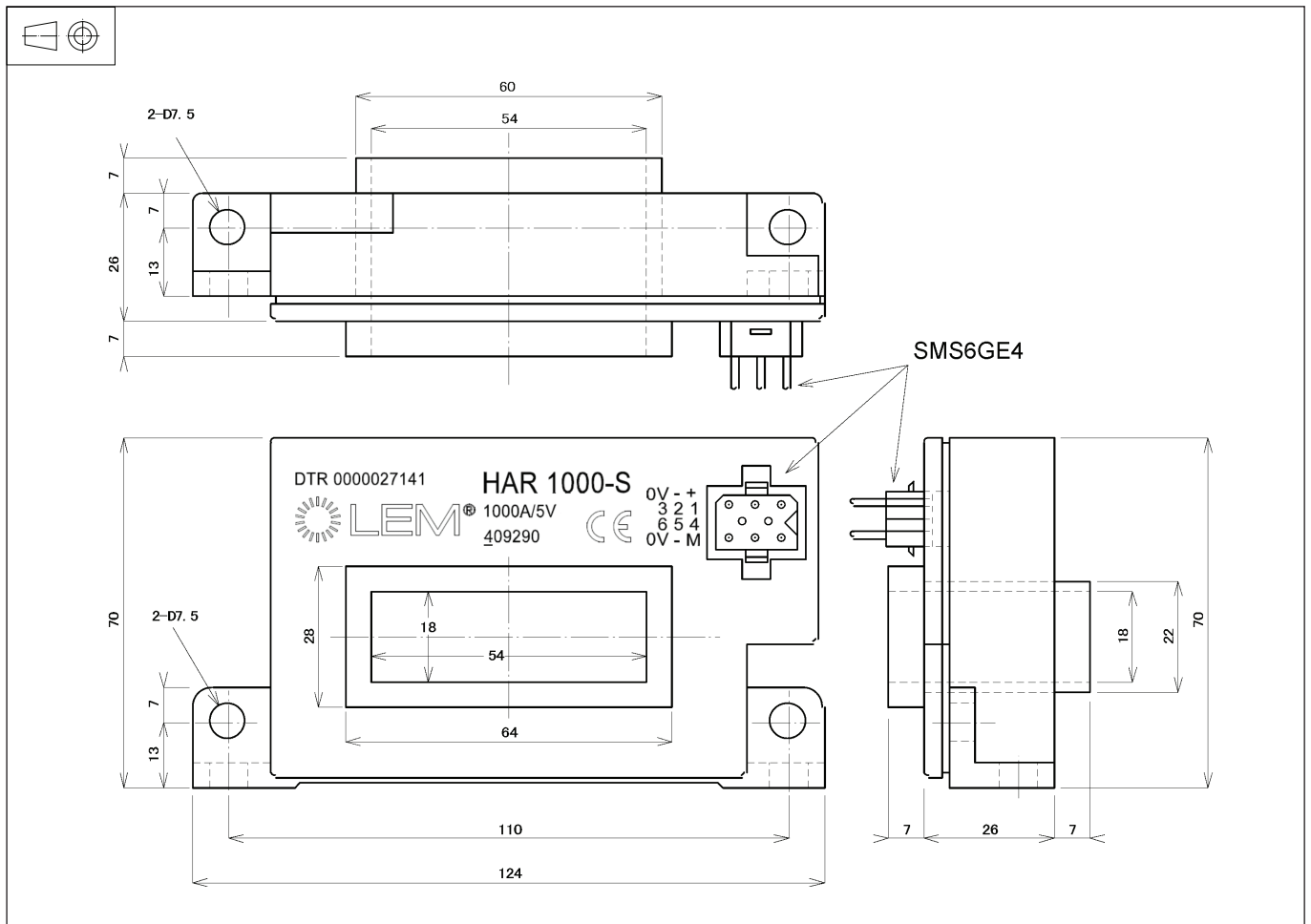

Secondary pins identification

- Pin 1 +15 V
- Pin 2 -15 V
- Pin 3 0 V
- Pin 4 Output
- Pin 5 -15 V
- Pin 6 0 V

Mechanical characteristics

- General tolerance ±1 mm
- Transducer fastening 4 holes Ø 7.5 mm
Recommended fastening torque 6.2 N·m max
- Aperture 54 mm × 18 mm
- Connection of secondary Bury SMSGE4 connector

Remarks

- I_s is positive when I_p flows in the direction of the arrow.
- Temperature of the primary conductor should not exceed 100 °C.
- Installation of the transducer must be done unless otherwise specified on the datasheet, according to LEM Transducer Generic Mounting Rules. Please refer to LEM document N°ANE120504 available on our Web site: [Products/Product Documentation](#).
- This is a standard model. For different versions (supply voltages, turns ratios, unidirectional measurements...), please contact us.