

ARU series

Ref: ARU-B100-D125, ARU-B100-D175, ARU-B100-D250, ARU-B100-D300

Outdoor flexible clip-around Rogowski coil for the electronic measurement of AC current with galvanic separation between the primary circuit (power) and the secondary circuit (measurement). The patented Perfect Loop Technology dramatically reduces both the error due to the position of the measured conductor within the aperture, and the error due to the proximity of external conductors.



Features

- Designed for outdoor use (UV, water, dust and ice standards)
- 100 mV/kA @ 50 Hz
- Flexible circular and teardrop shapes available
- Rated insulation CAT III 1000 V PD2, CAT IV 600 V PD3
- Class 0.5 (IEC 61869-10)
- Protection degree IPX8
- \varnothing 125, 175, 250 and 300 mm sensing aperture
- $T_A = -40 \dots +80^\circ\text{C}$
- An innovative patented clasp drastically reduces the positioning error near the closing
- Internal shield for enhanced measurement accuracy at low primary currents.

Advantages

- Flexible, and light weight solution
- Very low positioning error
- Very good accuracy
- Does not saturate with overcurrent and short circuits
- Fast and easy installation.

Applications

- Outdoor substations
- Distribution transformer monitoring
- Underground substations
- Pole-mounted transformers
- Overhead lines
- Distributions system equipment.

Standards

- IEC 61010-1: 2010; IEC 61010-2-32: 2012
- IEC 61869-10: 2017
- UL: (pending).

Application Domain

- Industrial
- Smartgrid.

Safety



Caution

If the device is used in a way that is not specified by the manufacturer, the protection provided by the device may be compromised. Always inspect the current sensor unit and connecting cable before using this product and do not use it if damaged (for example, if the contrasting color of the flexible rope is visible).

Mounting assembly shall guarantee the maximum primary busbar temperature, fulfill clearance and creepage distance, minimize electric and magnetic coupling, and unless otherwise specified can be mounted in any orientation



Caution, risk of electrical shock

This current sensor must be used in electric/electronic equipment with respect to applicable standards and safety requirements in accordance with the manufacturer's operating specifications.

This current sensor is intended for use in an electrical installation with restricted access. Therefore, in normal operation, it is not accessible. For installation or in maintenance phases, it is accessible only to qualified person.

It is intended to be connected onto SELV equipment input, of up to 30 Vrms.

When operating, certain parts of the current sensor can carry hazardous voltages (e.g. primary busbar, power supply).

De-energize all circuits and hazardous live parts before installing the product.

All installations, maintenance, servicing operations and use must be carried out by trained and qualified personnel practicing applicable safety precautions.

If the current sensor is used in a manner not specified by the manufacturer, the protection provided by the equipment may be impaired.

Ignoring this warning can lead to injury and/or cause serious damage.

This current sensor is a build-in device, whose hazardous live parts must be inaccessible after installation.

This current sensor must be mounted in a suitable end-enclosure.

Use caution during installation, use and uninstalling of this product; high voltages and currents, high temperature (above 70° C) may be present inside the electrical equipment.

Use personal protective equipment (clothes, gloves, ...).

This current sensor is a built-in device, not intended to be cleaned with any product. Nevertheless if the user must implement cleaning or washing process, validation of the cleaning program has to be done by himself.

Do not dispose of this product as unsorted municipal waste. Contact a qualified recycler for disposal.

Although LEM applies utmost care to facilitate compliance of end products with applicable regulations during LEM product design, use of this part may need additional measures on the application side for compliance with regulations regarding EMC and protection against electric shock. Therefore LEM cannot be held liable for any potential hazards, damages, injuries or loss of life resulting from the use of this product.



Caution! Risk of electrical shock

Do not apply around or remove from uninsulated hazardous live conductors which may result in electric shock, electric burn or arc flash.



Equipment protected throughout by double insulation or reinforced insulation.

Absolute maximum ratings

Parameter	Symbol	Unit	Value
Maximum secondary voltage (RMS)	$U_{S \max}$	V	30
Maximum primary conductor temperature	$T_{B \max}$	°C	105

Stresses above these ratings may cause permanent damage.
Exposure to absolute maximum ratings for extended periods may degrade reliability.

Insulation coordination

Parameter	Symbol	Unit	≤ Value	Comment
RMS voltage for AC insulation test, 50 Hz, 1 min	U_d	kV	7.4	According to IEC 61010-1
Impulse withstand voltage 1.2/50 μs	U_{Ni}	kV	12.8	According to IEC 61010-1
Partial discharge RMS test voltage ($q_m < 10$ pC)	U_t	V	1275	According to IEC 60664-1
Clearance (pri. - sec.)	d_{Cl}	mm	> 16	Shortest distance through air
Creepage distance (pri. - sec.)	d_{Cp}	mm	> 16	Shortest path along device body
Case material	-	-	V0	According to UL 94
Comparative tracking index	<i>CTI</i>		600	
Application example - indoor use RMS voltage line-to-neutral		V	1000	Reinforced insulation according to IEC 61010-1 CAT III ¹⁾ , PD2
Application example - outdoor use RMS voltage line-to-neutral		V	600	Reinforced insulation according to IEC 61010-1 CAT IV ²⁾ , PD3

Environmental and mechanical characteristics

Parameter	Symbol	Unit	Min	Typ	Max	Comment
Ambient operating temperature	T_A	°C	-40.		80	
Ambient storage temperature	T_S	°C	-40		80	
Relative humidity (non-condensing)	<i>RH</i>	%	0		90	
Altitude above sea level		m			2000	
Mass Ø 125	<i>m</i>	g		236		Cable length: 1.5 m
Mass Ø 175	<i>m</i>	g		247		Cable length: 1.5 m
Mass Ø 250	<i>m</i>	g		277		Cable length: 1.5 m
Mass Ø 300	<i>m</i>	g		297		Cable length: 1.5 m

Notes: ¹⁾ OVERVOLTAGE CATEGORY III is for equipment intended to form part of a building wiring installation.
²⁾ OVERVOLTAGE CATEGORY IV is for equipment installed at or near the origin of the electrical supply to a building, between the building entrance and the main distribution board.

Electrical data ARU-B100-D125

 At $T_A = 25\text{ °C}$, $R_L = 10\text{ k}\Omega$, unless otherwise noted.

Parameter	Symbol	Unit	Min	Typ	Max	Comment
Rated primary current	I_{Pr}	A				Not applicable ¹⁾
Rated short-time thermal current	I_{th}	kA		20		@ 50 Hz
Rated transformation ratio	k_{ra}	kA/V		10		@ 50 Hz
Rated frequency	f_r	Hz		50/60		
Secondary voltage	U_s	mV		100 120		@ 50 Hz, $I_p = 1\text{ kA}$ @ 60 Hz, $I_p = 1\text{ kA}$
Mutual inductance	M	nH		321.9		
Temperature coefficient of M	TCM	ppm/k		±30		
Frequency bandwidth (+3 dB) resonance (-3 dB)	BW	kHz		162 322 519		²⁾ Cable length: 1.5 m
Phase displacement ³⁾ @ 50/60 Hz	$\Delta\varphi$	°		0.007		²⁾
Coil inductance	L_s	μH		1080		
Coil resistance	R_s	Ω		113		
Ratio error (centered)	ε	%	-0.5		0.5	Class 0.5 accuracy according to IEC 61869-2
Ratio error (all positions)	ε	%	-1		1	⁴⁾
Linearity error	ε_L	%		None		
Error due to magnetic field of external conductor current	$\varepsilon_{I_{ext}}$	%	0	±0.4	±0.65	⁵⁾

- Notes:**
- ¹⁾ The Rogowski coil can measure any primary current as there is no saturation effect.
 - ²⁾ Frequency bandwidth and phase shift modeling schematic can be provided on request.
 - ³⁾ Referring to the main phase offset of 90 ° (a Rogowski coil is a derivative current transducer)
 - ⁴⁾ Considering a primary conductor of at least $\varnothing 18\text{ mm}$, perpendicular and on contact with the Rogowski coil.
 - ⁵⁾ Considering an external conductor of at least $\varnothing 18\text{ mm}$ the same current level than internal conductor, perpendicular and on contact with the Rogowski coil.

Electrical data ARU-B100-D175

 At $T_A = 25\text{ °C}$, $R_L = 10\text{ k}\Omega$, unless otherwise noted.

Parameter	Symbol	Unit	Min	Typ	Max	Comment
Rated primary current	I_{Pr}	A				Not applicable ¹⁾
Rated short-time thermal current	I_{th}	kA		20		@ 50 Hz
Rated transformation ratio	k_{ra}	kA/V		10		@ 50 Hz
Rated frequency	f_r	Hz		50/60		
Secondary voltage	U_s	mV		100 120		@ 50 Hz, $I_p = 1\text{ kA}$ @ 60 Hz, $I_p = 1\text{ kA}$
Mutual inductance	M	nH		322.4		
Temperature coefficient of M	TCM	ppm/k		±30		
Frequency bandwidth (+3 dB) resonance (-3 dB)	BW	kHz		165 299 455		²⁾ Cable length: 1.5 m
Phase displacement ³⁾ @ 50/60 Hz	$\Delta\varphi$	°		0.004		²⁾
Coil inductance	L_s	μH		1244		
Coil resistance	R_s	Ω		128		
Ratio error (centered)	ε	%	-0.5		0.5	Class 0.5 accuracy according to IEC 61869-2
Ratio error (all positions)	ε	%	-1		1	⁴⁾
Linearity error	ε_L	%		None		
Error due to magnetic field of external conductor current	$\varepsilon_{f_{ext}}$	%	0	±0.4	±0.65	⁵⁾

- Notes:**
- ¹⁾ The Rogowski coil can measure any primary current as there is no saturation effect.
 - ²⁾ Frequency bandwidth and phase shift modeling schematic can be provided on request.
 - ³⁾ Referring to the main phase offset of 90 ° (a Rogowski coil is a derivative current transducer)
 - ⁴⁾ Considering a primary conductor of at least $\varnothing 18\text{ mm}$, perpendicular and on contact with the Rogowski coil.
 - ⁵⁾ Considering an external conductor of at least $\varnothing 18\text{ mm}$ the same current level than internal conductor, perpendicular and on contact with the Rogowski coil.

Electrical data ARU-B100-D250

 At $T_A = 25\text{ °C}$, $R_L = 10\text{ k}\Omega$, unless otherwise noted.

Parameter	Symbol	Unit	Min	Typ	Max	Comment
Rated primary current	I_{Pr}	A				Not applicable ¹⁾
Rated short-time thermal current	I_{th}	kA		20		@ 50 Hz
Rated transformation ratio	k_{ra}	kA/V		10		@ 50 Hz
Rated frequency	f_r	Hz		50/60		
Secondary voltage	U_S	mV		100 120		@ 50 Hz, $I_p = 1\text{ kA}$ @ 60 Hz, $I_p = 1\text{ kA}$
Mutual inductance	M	nH		323.9		
Temperature coefficient of M	TCM	ppm/k		±30		
Frequency bandwidth (+3 dB resonance (-3 dB))	BW	kHz		145 252 382		²⁾ Cable length: 1.5 m
Phase displacement ³⁾ @ 50/60 Hz	$\Delta\varphi$	°		0.007		²⁾
Coil inductance	L_S	μH		1701		
Coil resistance	R_S	Ω		175		
Ratio error (centered)	ε	%	-0.5		0.5	Class 0.5 accuracy according to IEC 61869-2
Ratio error (all positions)	ε	%	-1		1	⁴⁾
Linearity error	ε_L	%		None		
Error due to magnetic field of external conductor current	$\varepsilon_{I_{ext}}$	%	0	±0.4	±0.65	⁵⁾

- Notes:**
- ¹⁾ The Rogowski coil can measure any primary current as there is no saturation effect.
 - ²⁾ Frequency bandwidth and phase shift modeling schematic can be provided on request.
 - ³⁾ Referring to the main phase offset of 90 ° (a Rogowski coil is a derivative current transducer)
 - ⁴⁾ Considering a primary conductor of at least Ø18 mm, perpendicular and on contact with the Rogowski coil.
 - ⁵⁾ Considering an external conductor of at least Ø18 mm the same current level than internal conductor, perpendicular and on contact with the Rogowski coil.

Electrical data ARU-B100-D300

 At $T_A = 25\text{ °C}$, $R_L = 10\text{ k}\Omega$, unless otherwise noted.

Parameter	Symbol	Unit	Min	Typ	Max	Comment
Rated primary current	I_{Pr}	A				Not applicable ¹⁾
Rated short-time thermal current	I_{th}	kA		20		@ 50 Hz
Rated transformation ratio	k_{ra}	kA/V		10		@ 50 Hz
Rated frequency	f_r	Hz		50/60		
Secondary voltage	U_S	mV		100 120		@ 50 Hz, $I_p = 1\text{ kA}$ @ 60 Hz, $I_p = 1\text{ kA}$
Mutual inductance	M	nH		324.9		
Temperature coefficient of M	TCM	ppm/k		± 30		
Frequency bandwidth (+3 dB resonance (-3 dB))	BW	kHz		134 230 346		²⁾ Cable length: 1.5 m
Phase displacement ³⁾ @ 50/60 Hz	$\Delta\varphi$	°		0.007		²⁾
Coil inductance	L_S	μH		2018		
Coil resistance	R_S	Ω		208		
Ratio error (centered)	ε	%	-0.5		0.5	Class 0.5 accuracy according to IEC 61869-2
Ratio error (all positions)	ε	%	-1		1	⁴⁾
Linearity error	ε_L	%		None		
Error due to magnetic field of external conductor current	$\varepsilon_{J_{ext}}$	%	0	± 0.4	± 0.65	⁵⁾

- Notes:**
- ¹⁾ The Rogowski coil can measure any primary current as there is no saturation effect.
 - ²⁾ Frequency bandwidth and phase shift modeling schematic can be provided on request.
 - ³⁾ Referring to the main phase offset of 90 ° (a Rogowski coil is a derivative current transducer)
 - ⁴⁾ Considering a primary conductor of at least $\varnothing 18\text{ mm}$, perpendicular and on contact with the Rogowski coil.
 - ⁵⁾ Considering an external conductor of at least $\varnothing 18\text{ mm}$ the same current level than internal conductor, perpendicular and on contact with the Rogowski coil.

Definition of typical, minimum and maximum values

Minimum and maximum values for specified limiting and safety conditions have to be understood as such as well as values shown in “typical” graphs.

On the other hand, measured values are part of a statistical distribution that can be specified by an interval with upper and lower limits and a probability for measured values to lie within this interval.



Unless otherwise stated (e.g. “100 % tested”), the LEM definition for such intervals designated with “min” and “max” is that the probability for values of samples to lie in this interval is 99.73 %.

For a normal (Gaussian) distribution, this corresponds to an interval between -3 sigma and +3 sigma. If “typical” values are not obviously mean or average values, those values are defined to delimit intervals with a probability of 68.27 %, corresponding to an interval between -sigma and +sigma for a normal distribution.

Typical, minimum and maximum values are determined during the initial characterization of the product.

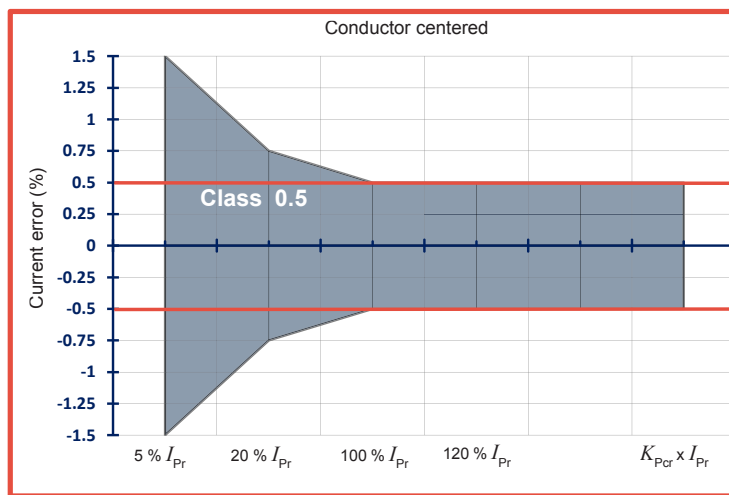
Accuracy class according to IEC 61869-10



-  Accuracy class limit of IEC 61869-10
-  Accuracy class limit of ARU-B100 Rogowski

ARU-B100-D125, ARU-B100-D175, ARU-B100-D300

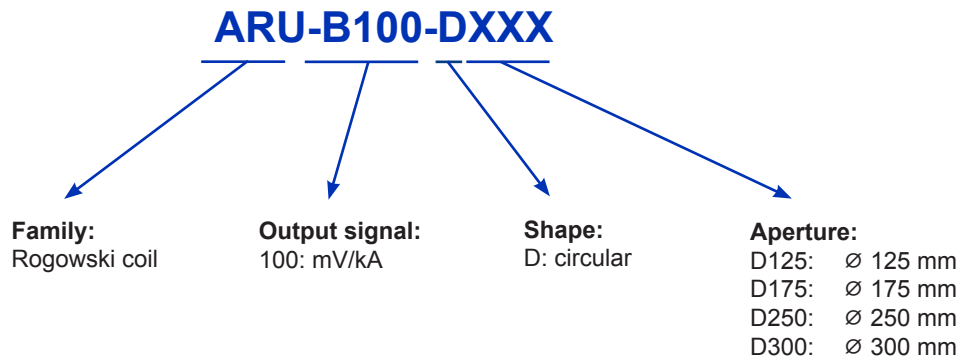

Other cable lengths available:

Product name	Length (m)	Mass (g)
ARU-B100-D125/SP3	3	298
ARU-B100-D125/SP4	4.5	359
ARU-B100-D125/SP6	6	421
ARU-B100-D175/SP3	3	309
ARU-B100-D175/SP4	4.5	370
ARU-B100-D175/SP6	6	432
ARU-B100-D250/SP3	3	339
ARU-B100-D250/SP4	4.5	400
ARU-B100-D250/SP6	6	462
ARU-B100-D300/SP3	3	359
ARU-B100-D300/SP4	4.5	420
ARU-B100-D300/SP6	6	482

Terms and definitions

Rated transformation ratio k_{ra}

Ratio of k_{ra} to the actual secondary voltage.

Ratio error ε

The current ratio error, expressed as a percentage, is defined by the formula:

Where:

k_{ra} : is the rated transformation ratio

I_p : is the actual primary current

U_s : is the actual secondary voltage when I_p is flowing

Phase displacement $\Delta\varphi$

The $\Delta\varphi$ is the difference in phase between the primary current and the ideal secondary voltage phasors. The direction of the phasors being that the angle is 90 ° (leading) for an ideal Rogowski coil.

The phase displacement is said to be positive when the secondary voltage phasor leads the primary current phasor.

Linearity error ε_L

The linearity error ε_L is the maximum positive or negative difference between the measured points and the linear regression line, expressed as a percentage of I_{pr} .

Rated short-time thermal current I_{th}

Maximum value of the primary current which the Rogowski will withstand for a specified short time without suffering harmful effects.

Dimensions (in mm)

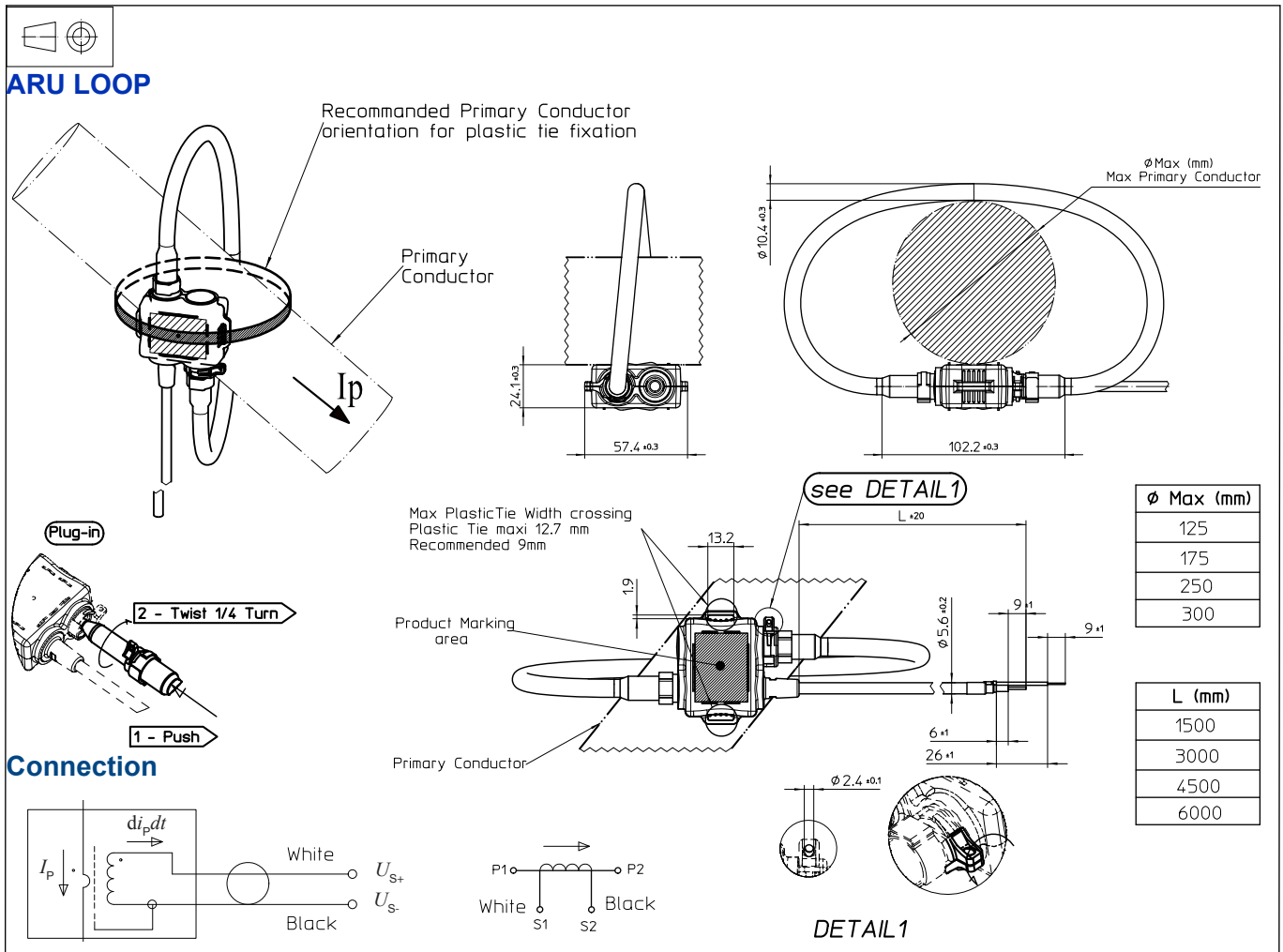

Mechanical characteristics

- General tolerance ± 1 mm
- Output cable length See table page 10 or drawing above
- Termination 2 stripped wires 0,5 mm² (AWG 20)
- Cable tie maximum effort 50 N

Remarks

- $U_s = U_{S+} - U_{S-}$ is positive when an increasing primary current di/dt flows in the direction of the arrow.
- Due to low positioning error (ϵ_{POS}), the device does not need to be physically fastened around the primary conductor. Should the device be secured, make sure no mechanical stress is applied to the coil itself.