

High Performance Current Sensing for Automation Applications

PRODUCT CATALOG

2023



- Current Sensing Switches
- AC Current Transducers
- DC Current Transducers
- Ground Fault Protection
- Voltage Transducers
- Power Sensing Products
- Signal Converters
- Current Transformers
- AMPFlasher™ Current Indicator
- Accessories

www.nktechnologies.com

800.959.4014



Current Sensors for Automation

A Company Built Upon A History Of Innovation

Founded in 1982, when Maynard Kuljian saw the need for an economical way to measure current draw, Neilsen-Kuljian, Inc., became the first to develop the low-cost solid-state current sensing technology that underlies the industry today.

True to this heritage, NK Technologies has maintained a focus on developing and manufacturing innovative, cost-effective current sensing products designed to add value and to meet or exceed our customers' performance expectations. With a portfolio of over 1300 models, NK Technologies remains a leading supplier of current measurement solutions to the industrial and factory automation markets. As the needs of these markets change, NK Technologies is well-positioned to respond with sophisticated new product designs and improved product functionality necessary to meet those applications.

As a leader in the industry, NK Technologies takes its commitment to customers seriously and considers customer satisfaction a top priority. Timely response to customer inquiries; knowledgeable technical support; a willingness to develop custom solutions to meet specific customer needs; and an organizational commitment to delivering reliable, quality product on time are the hallmarks of excellence which our customers have come to rely on and expect from NK Technologies, a company built upon a history of innovation.



www.nktechnologies.com

Go online for more information

- Up-to-date Product Information
- Application Examples
- Engineering Resource Articles
- Sign Up for Product Updates
- Distributor Information

For over three decades, NK Technologies has remained the **premier manufacturer** of Current Sensors and Transducers serving the factory and industrial automation markets.

With one of the broadest product portfolios in the industry, NK Technologies provides reliable, innovative current sensing products designed to add value and exceed our customers' expectations. "From motor monitoring to heater status, semiconductor tools to water/wastewater plants, NK Technologies has a family of current sensors to meet your application needs." — Phil Gregory, President

CONTENTS

| | | |
|---|---|--|
| Current Sensing Switches4 | Ground Fault Protection90 | AMPFlasher™ 146 |
| Selection Guide.....5 | Selection Guide.....90 | AMPFlasher™ ACI |
| AS1, AS1 Compact Case, AS1 NOR-FT-GO, AS3, ASL, ASM, ASC, ASD, AS0, ASX, ASP-FD, ASXP, ASXP-MS, ASXP-LS, ATS, DS1, DS3, DS1-FD | AG, AGV, AGL, AGLD, AG-LC, AGT, AGT-FD, DG | Accessories 147 |
| AC Current Transducers40 | Voltage Transducers111 | DIN Rail Kits |
| Selection Guide.....41 | Selection Guide.....111 | Index by Name 151 |
| AT, ATR, AT/ATR-TH, AT/ATR-FD, AT/ATR-FL, AT/ATR-MS, AT/ATR-LS, ATCR, ATP, ATPR, ATP/ATPR-FL, ATH, ATQ, ATS | VTR, VTD, VTD-BD, VTU-OS, VTU-DIN | Index by Product 152 |
| DC Current Transducers72 | Power Sensing Products122 | RoHS 2/ISO/Terms & Conditions |
| Selection Guide.....72 | Selection Guide.....122 | See the Inside Back Cover of this catalog for: |
| DT 4-Wire Split-Core, DT 4-Wire Solid-Core, DT 3-Wire, DT 5 & 12 VDC, DT-FD High Voltage, DT-DL Large Aperture, DLT 2-Wire Looped Power | APN, APN-R, APS, APT, APT-TH | • RoHS Certificate of Compliance |
| | Signal Converters133 | • ISO-9001 and ISO-14001 Certification |
| | Selection Guide.....133 | • Terms & Conditions |
| | ADC, CTC | |
| | Current Transformers138 | |
| | CT-MS & CT-LS, Current Transformers, CTRC, ProteCT™, | |

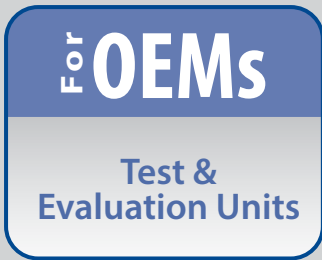

We will help you ... for FREE!

The New NK Technologies Test & Evaluation Program can expedite your evaluation process by getting the right product in your engineers hands for evaluation fast and free!

- ✓ **Are you an OEM using switches and transducers on the equipment you sell to your customers?**
- ✓ **Are you looking for a test & evaluation unit?**
- ✓ **Would you like to avoid the time & hassle associated with buying a unit?**

Get your design moving forward by following these simple steps:

- #1 - Complete following form at www.nktechnologies.com/testunit/
- #2 - Meet either in person or by telephone with our Application Engineering team to discuss your product selection so we can confirm the product you have selected is best for your application.

#3 - NK Technologies will ship you your test & evaluation unit at no cost.

#4 - You agree to meet either in person or by phone sometime in the next 60 days to review the product operation, analyze test results and coordinate a plan to move forward with the design.

It's that easy ... so start today!



Current Sensing Switches

Ideal for off/on status, overload or underload indication, current sensing switches from NK Technologies combine a CT, signal conditioner and output contacts into a single package for use with industrial and factory automation equipment.

Features:

- Multiple output ranges
- Adjustable or fixed setpoints
- Models with integral time delay available
- Choice of N.O or N.C., AC or DC contacts
- Self-powered and split-core options

| | | |
|---|---|---------|
| ● AS1 SERIES | Current Sensing Switches | page 6 |
| ● AS1 SERIES COMPACT CASE | AC Current Sensing Switches | page 13 |
| ● AS1 NOR-FT-GO SERIES | Current Sensing Switches | page 8 |
| ● AS3 SERIES | Current Sensing Switches | page 10 |
| ● ASL SERIES | Linear Adjustment Setpoint Switches | page 14 |
| ● ASM SERIES | Self-calibrating Current Sensing Smart Switches | page 16 |
| ● ASC SERIES | Factory-calibrated Current Operated Switches | page 18 |
| ● ASD SERIES | Current Sensing Switches | page 20 |
| ● ASO SERIES | Current Sensing Switches | page 22 |
| ● ASX SERIES | Current Sensing Switches | page 24 |
| ● ASP-FD SERIES | Current Sensing Switches | page 26 |
| ● ASXP SERIES | Current Sensing Switches | page 28 |
| ● ASXP-MS SERIES | Current Sensing Switches | page 30 |
| ● ASXP-LS SERIES | Current Sensing Switches | page 32 |
| ● ATS SERIES WITH DIGITAL SETPOINT DISPLAY | Current Sensing Transducers/Switches | page 68 |
| ● ATS SERIES WITH ROTARY SWITCH SETPOINT | Current Sensing Transducers/Switches | page 70 |
| ● DS1 SERIES | DC Current Sensing Switches | page 34 |
| ● DS3 SERIES | Current Sensing Switches | page 36 |
| ● DS1-FD SERIES | DC or AC Current Sensing Switches | page 38 |

CURRENT SENSING SWITCHES
Selection Chart

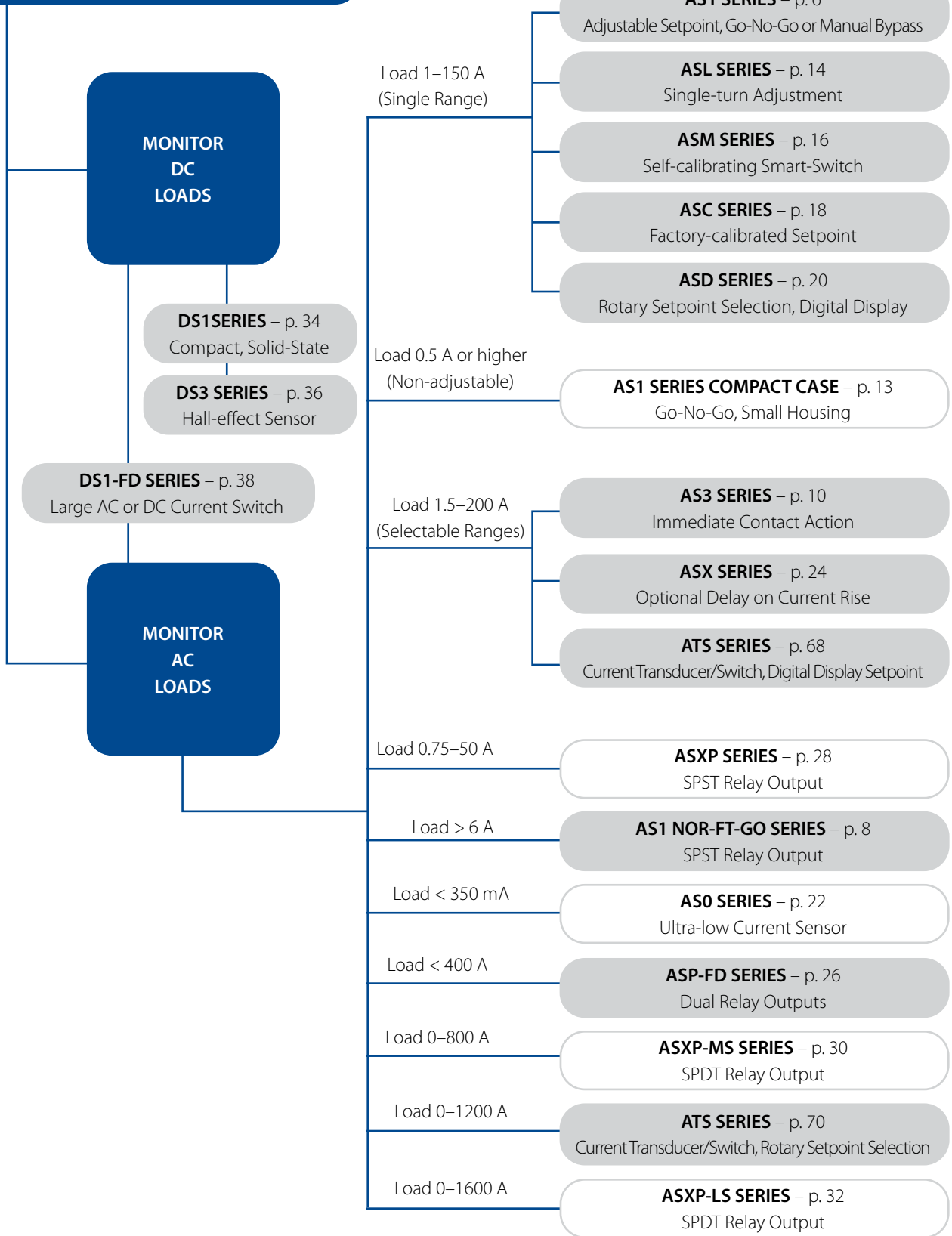

AS1 SERIES

Current Sensing Switches

AS1 Series Current Sensing Switches combine a current transformer, signal conditioner and limit alarm into a single package for use in status monitoring or proof of operation applications. Offering an extended setpoint range of 1–150 A and universal, solid-state outputs, the self-powered AS1 can be tailored to provide accurate and dependable digital indication of overcurrent conditions across a broad range of applications. Available in solid-core case styles or in a split-core case to maximize ease of installation.



Current Sensing Switch Applications

Electronic Proof of Flow

- Current sensing switches eliminate the need for multiple pipe or duct penetrations and are more reliable than electromechanical pressure or flow switches.

Conveyors

- Detects jams and overloads.
- Interlocks multiple conveyor sections.

Lighting Circuits

- Proof positive that the lamp is energized.

Electrical Heaters

- Faster response than temperature sensors.

Current Sensing Switch Features

Universal Output

- N.O. or N.C. solid-state switch for control circuits up to 240 VAC/DC.
- Compatible with most automation systems.

Self-powered

- Cuts installation and operating costs.

Easily Adjustable Setpoint

- Speeds startup.

Solid or Split-core Case

- Versions tailored for each installation.

LED Indication

- Provides quick visual indication of contact status.

Built-in Mounting Feet

- Simple, two-screw panel mounting or attach with DIN rail brackets (included).*

UL/cUL and CE Approved

- Accepted worldwide.

*For information on the DIN rail accessories kit, see page 147.

Pump Jam & Suction Loss Protection

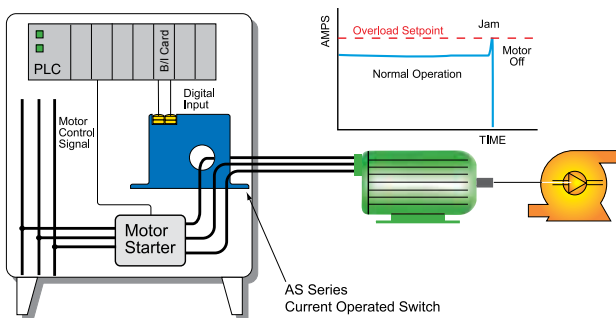

For additional Application Examples, go to www.nktechnologies.com/applications

Current Sensing Switch Connections

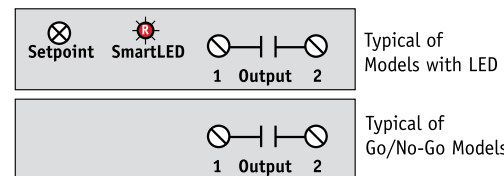

OEMs

Test & Evaluation Units for OEMs

Free program expedites evaluation process. See page 3 for details.

Current Sensing Switch Dimensions

FF Case

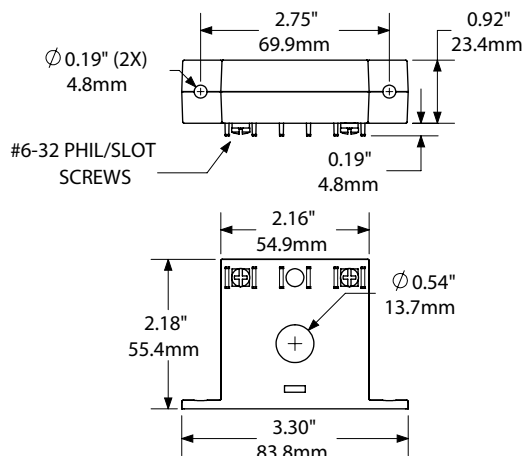

FT Case

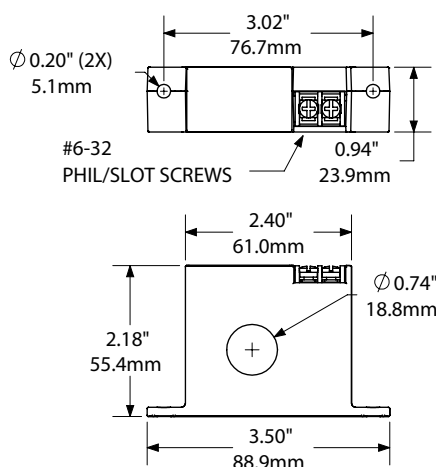

SP Case

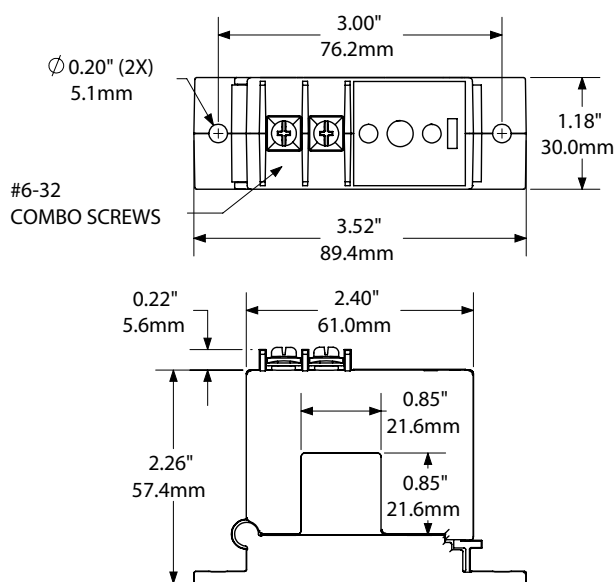

Current Sensing Switch Specifications



| Power Supply | None, self-powered | | | | | | | | | | | | | | | | |
|--------------------------|---|---------|------------|--------|--------|-------------|---------|---------|----------|-------------|---------|---------|----------|-------------|---------|---------|----------|
| Setpoint Range | <ul style="list-style-type: none"> • Solid-core: 1–150 A (adjustable-specific models) • Split-core: 1.75–150 A (adjustable-specific models) | | | | | | | | | | | | | | | | |
| Output Switch | Isolated solid-state switch | | | | | | | | | | | | | | | | |
| Output Rating | <ul style="list-style-type: none"> • N.O. Version: 0.15 A @ 240 VAC or VDC • N.C. Version: 0.2 A @ 135 VAC or VDC • Not polarity sensitive | | | | | | | | | | | | | | | | |
| Off-state Leakage | <10 μ A | | | | | | | | | | | | | | | | |
| Response Time | 120 ms max. | | | | | | | | | | | | | | | | |
| Time Delay | None | | | | | | | | | | | | | | | | |
| Hysteresis | 5% of Setpoint | | | | | | | | | | | | | | | | |
| Overload | <table border="1"> <thead> <tr> <th>MODEL</th> <th>CONTINUOUS</th> <th>6 SEC.</th> <th>1 SEC.</th> </tr> </thead> <tbody> <tr> <td>• -GO (NOU)</td> <td>• 250 A</td> <td>• 500 A</td> <td>• 1000 A</td> </tr> <tr> <td>• -GO (NCU)</td> <td>• 150 A</td> <td>• 400 A</td> <td>• 1000 A</td> </tr> <tr> <td>• All other</td> <td>• 150 A</td> <td>• 400 A</td> <td>• 1000 A</td> </tr> </tbody> </table> | MODEL | CONTINUOUS | 6 SEC. | 1 SEC. | • -GO (NOU) | • 250 A | • 500 A | • 1000 A | • -GO (NCU) | • 150 A | • 400 A | • 1000 A | • All other | • 150 A | • 400 A | • 1000 A |
| MODEL | CONTINUOUS | 6 SEC. | 1 SEC. | | | | | | | | | | | | | | |
| • -GO (NOU) | • 250 A | • 500 A | • 1000 A | | | | | | | | | | | | | | |
| • -GO (NCU) | • 150 A | • 400 A | • 1000 A | | | | | | | | | | | | | | |
| • All other | • 150 A | • 400 A | • 1000 A | | | | | | | | | | | | | | |
| Isolation Voltage | UL listed to 1480 VAC | | | | | | | | | | | | | | | | |
| Frequency Range | 6–100 Hz | | | | | | | | | | | | | | | | |
| Case | UL94 V-0 Flammability Rated | | | | | | | | | | | | | | | | |
| Environmental | -4 to 122°F (-20 to 50°C) 0–95% RH, non-condensing | | | | | | | | | | | | | | | | |
| Listings | UL /cUL, CE | | | | | | | | | | | | | | | | |

Current Sensing Switch Ordering Information

Sample Model Number: AS1-NOU-SP

Adjustable AC current sensing switch, normally open, split-core case. (DIN rail adapters are included)



(1) Output Rating

| | |
|-----|-----------------|
| NOU | Normally Open |
| NCU | Normally Closed |

(2) Case Style

| | |
|----|----------------------------|
| FF | Solid-core, front terminal |
| FT | Solid-core, top terminal |
| SP | Split-core |

(3) Options

| | |
|-----|---|
| | Standard, with LED (blank) |
| GO | Non-adjustable; output changes with min. current present (solid-core 0.75 A, split-core 1.25 A) |
| NL | No LED |
| Y39 | Output Bypass Switch (not UL listed) – available for FT case only |

Current Sensing Switches



AS1 NOR-FT-GO SERIES

Current Sensing Switches

AS1 NOR-FT-Go Series Current Sensing Switches provide an electromechanical relay contact. The output of this specialized switch allows the sensor to control much more current than other AS1 models. This contact can control loads up to 5 A, AC or DC. Solid-state contacts generally have a much lower capacity, making this sensor much more versatile than most self-powered models. Available in a solid-core case only.



Current Sensing Switch Applications

Electronic Proof of Flow

- Current sensing switches eliminate the need for multiple conduits or duct penetrations and are more reliable than electromechanical pressure or flow switches.

Compressor Monitoring

- Detect when the compressor is running.
- Allows for time of use logging; helps maintenance scheduling.

Heaters

- Sense system operation.

Fan Interlocks

- Sense system operation.
- Use to turn on a duct booster fan when clothes dryer is energized.

Current Sensing Switch Features

Electromechanical Output

- N.O. mechanical output relay for detection of current; closes on current increase.

Fixed Setpoint

- Cuts installation and operating costs.

Self-powered

- Reduces installation time and costs.

Integral Mounting Feet

- Built-in feet for direct panel mounting or attachment of DIN rail compatible brackets.*

UL/cUL Approved

- Accepted worldwide.

*For information on the DIN rail accessories kit, see page 147.

Current Sensing Switch Monitoring a Fan Load

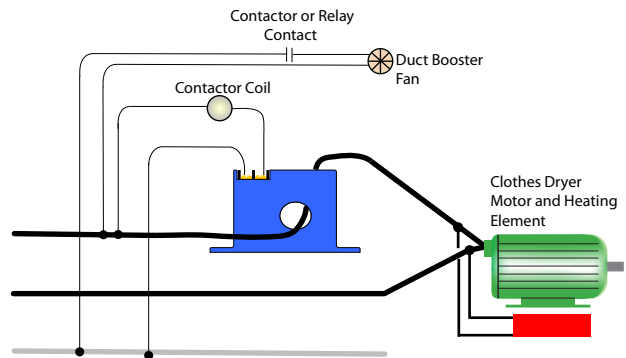

- For additional Application Examples, go to www.nktechnologies.com/applications



Test & Evaluation Units for OEMs

Free program expedites evaluation process. See page 3 for details.



Current Sensing Switch Dimensions

FT Case

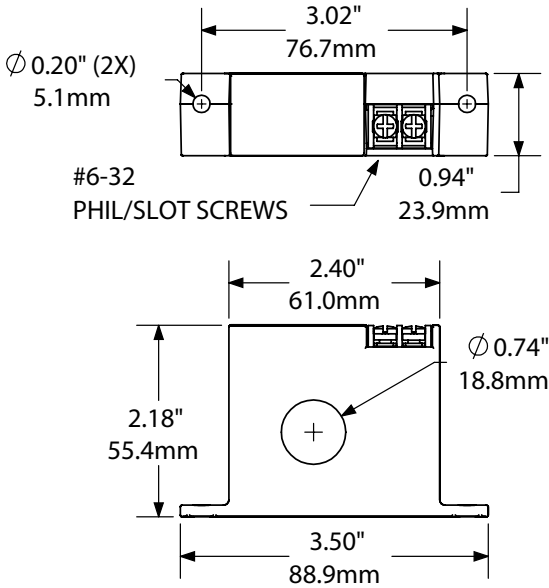

Current Sensing Switch Connections

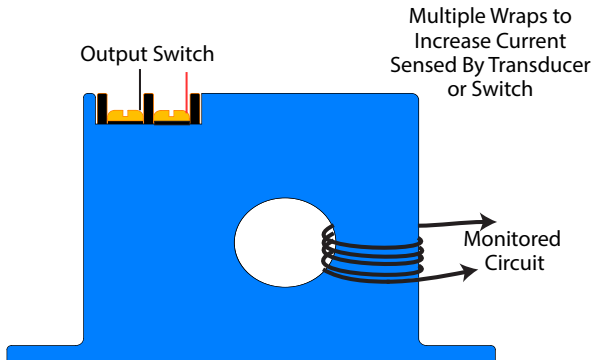
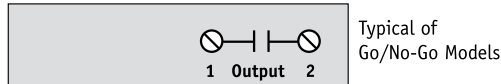

Current Sensing Switch Specifications



| | |
|--------------------------|---|
| Power Supply | None, self-powered |
| Setpoint Range | Go/No-go 5.8 A (factory set) |
| Output Switch | Electromechanical SPST relay |
| Output Rating | • 5 A @ 250 VAC • 5 A @ 30 VDC |
| Response Time | 120 ms |
| Time Delay | None |
| Hysteresis | 8% of Setpoint |
| Overload | 6 sec. @ 400 A, 1 sec. @1000 A |
| Isolation Voltage | UL listed to 1500 VAC, tested to 5 KV |
| Frequency Range | 6–100 Hz |
| Case | UL94 V-0 Flammability Rated |
| Environmental | -4 to 122°F (-20 to 50°C) 0–95% RH, non-condensing |
| Listings | UL/cUL |

Current Sensing Switch Ordering Information

Sample Model Number: AS1-NOR-FT-GO
AC current operated switch, solid-core, non-adjustable trip point (5.8 A), self-powered, normally open relay contact output rated to 5 A. (DIN rail adapters are included)



(1) Output Description

| | |
|-----|----------------------------|
| NOR | Normally Open (mechanical) |
|-----|----------------------------|

(2) Case Style

| | |
|----|---------------------------|
| FT | Solid-core, top terminals |
|----|---------------------------|

(3) Options

| | |
|----|---|
| GO | Go/no-go version (fixed setpoint @ 5.8 A) |
|----|---|

Current Sensing Switches



AS3 SERIES

Current Sensing Switches

AS3 Series Current Sensing Switches provide the same dependable indication of status offered by the AS1, but with the added benefit of increased setpoint accuracy. A choice of three, jumper-selectable input ranges allows the AS3 to be tailored to an application, providing more precise control through improved setpoint resolution. Self-powering, isolated solid-state outputs, 1–6 A, 6–40 A and 40–200 A input ranges, and a choice of split- or solid-core case are standard.

Current Sensing Switch Applications

Electronic Proof of Flow

- No need for pipe or duct penetrations.
- More reliable than electromechanical pressure or flow switches.

Conveyors

- Detects jams and overloads.
- Interlocks multiple conveyor sections.

Lighting Circuits

- Easier to install and more accurate than photocells.

Electrical Heaters

- Faster response than temperature sensors.

Pump Jam & Suction Loss Protection

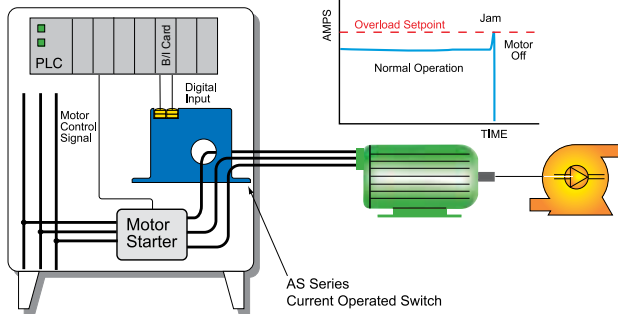

- For additional Application Examples, go to www.nktechnologies.com/applications

OEMs

Test & Evaluation Units for OEMs

Free program expedites evaluation process. See page 3 for details.



Current Sensing Switch Features

Choice of N.O. or N.C. Solid-state Outputs

- 1 A @ 240 VAC, 0.15 A @ 30 VDC.
- 15 A @ 120 VAC (-15 model).
- 3 A @ 120 VAC (-03 model).

Self-powered

- Cuts installation and operating costs.

Easily Adjustable Setpoint

- Speeds startup.

Solid- or Split-core Case

- Choose the appropriate version for each installation.

LED Indication

- Provides quick visual indication of contact status.

Built-in Mounting Feet

- Provides the secure installation inspectors require.

UL/cUL and CE Approved

- Accepted worldwide.

AS1, AS3, ASX, ASXP Series Sample Output

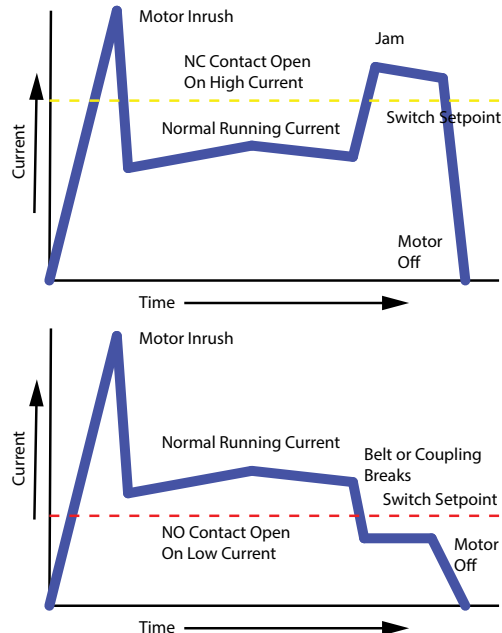

Current Sensing Switch Dimensions

FF Case

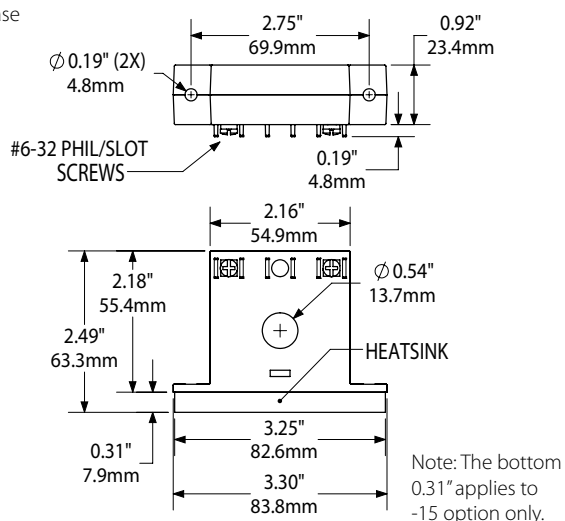

FT Case

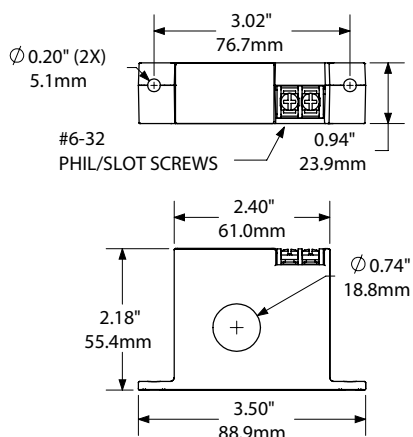

SP Case

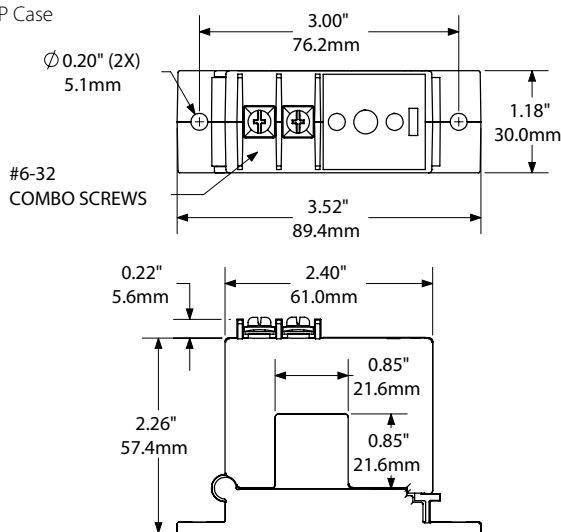

Current Sensing Switch Connections

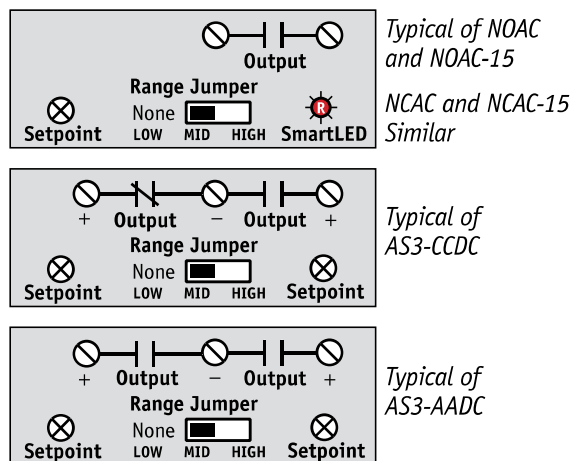

Note: Terminals are #6 screws. DC contacts are polarity sensitive.

Current Sensing Switch Specifications



| Power Supply | None, self-powered | | | | | | | | | | | | | | | | |
|--------------------------|---|---------|------------|--------|--------|---------|---------|---------|---------|----------|---------|---------|---------|------------|---------|---------|----------|
| Setpoint Range | <ul style="list-style-type: none"> Solid-core: 1-6, 6-40 & 40-175 A (adjustable) Split-core: 1.75-6, 6-40 & 40-200 A (adjustable) | | | | | | | | | | | | | | | | |
| Output Switch | Isolated solid-state switch | | | | | | | | | | | | | | | | |
| Output Rating | <ul style="list-style-type: none"> 1.0 A @ 240 VAC (standard AC units) 0.15 A @ 30 VDC (standard DC & multi-pole units) 3 A @ 120 VAC (-03 option) 15 A @ 120 VAC, 10 A @ 240 VAC (-15 option) When mounted on 1ft², 930 cm² metal surface. Max 3 A in free air. | | | | | | | | | | | | | | | | |
| Off-state Leakage | <ul style="list-style-type: none"> NOAC: <10 μA NCAC: 2.5 mA AADC: <10 μA NODC: <10 μA NCDC: 1.35 mA CCDC: 0.3 mA (N.C. Terminal) | | | | | | | | | | | | | | | | |
| Response Time | 2.5 sec. max. | | | | | | | | | | | | | | | | |
| Time Delay | None | | | | | | | | | | | | | | | | |
| Hysteresis | 5% of Setpoint | | | | | | | | | | | | | | | | |
| Overload | <table border="1"> <thead> <tr> <th>RANGE</th> <th>CONTINUOUS</th> <th>6 SEC.</th> <th>1 SEC.</th> </tr> </thead> <tbody> <tr> <td>• 1-6 A</td> <td>• 150 A</td> <td>• 400 A</td> <td>• 600 A</td> </tr> <tr> <td>• 6-40 A</td> <td>• 150 A</td> <td>• 500 A</td> <td>• 800 A</td> </tr> <tr> <td>• 40-175 A</td> <td>• 210 A</td> <td>• 800 A</td> <td>• 1200 A</td> </tr> </tbody> </table> | RANGE | CONTINUOUS | 6 SEC. | 1 SEC. | • 1-6 A | • 150 A | • 400 A | • 600 A | • 6-40 A | • 150 A | • 500 A | • 800 A | • 40-175 A | • 210 A | • 800 A | • 1200 A |
| RANGE | CONTINUOUS | 6 SEC. | 1 SEC. | | | | | | | | | | | | | | |
| • 1-6 A | • 150 A | • 400 A | • 600 A | | | | | | | | | | | | | | |
| • 6-40 A | • 150 A | • 500 A | • 800 A | | | | | | | | | | | | | | |
| • 40-175 A | • 210 A | • 800 A | • 1200 A | | | | | | | | | | | | | | |
| Isolation Voltage | UL listed to 1480 VAC | | | | | | | | | | | | | | | | |
| Frequency Range | 6-100 Hz | | | | | | | | | | | | | | | | |
| Case | UL94 V-0 Flammability Rated | | | | | | | | | | | | | | | | |
| Environmental | -4 to 122°F (-20 to 50°C) 0-95% RH, non-condensing -03/-15 versions 104°F (40°C) ambient | | | | | | | | | | | | | | | | |
| Listings | UL/cUL, CE | | | | | | | | | | | | | | | | |



Current Sensing Switch Ordering Information

Sample Model Number: AS3-NOAC-FF-NL

Adjustable AC current sensing switch, normally open AC contacts, solid-core case, without indicating LED. (DIN rail adapters are included)

**(1) Output Rating**

| | |
|------|--|
| NOAC | Normally Open, 1 A @ 240 VAC |
| NCAC | Normally Closed, 1 A @ 240 VAC |
| NODC | Normally Open, 0.15 A @ 30 VDC |
| NCDC | Normally Closed, 0.15 A @ 30 VDC |
| AADC | Dual, Normally Open, 0.15 A @ 30 VDC (-FF only) |
| CCDC | 1 N.O., 1 N.C. Solid State, 0.15 A @ 30 VDC (-FF only) |

(2) Case Style

| | |
|----|----------------------------|
| FF | Solid-core, front terminal |
| SP | Split-core |
| FT | Solid-core, top terminal |

(3) Options

| | |
|----|---------------------------|
| NL | No LED |
| 03 | 3 A @ 120 VAC (-FT only) |
| 15 | 15 A @ 120 VAC (-FF only) |
| | (Blank is standard) |



The AS3 series current sensing switches are the go-to models for a huge variety of applications. The models designed to control AC circuits can be manufactured with 1, 3 or 15 A capacities. The models with DC capabilities can be manufactured with dual contacts, adjustable between the selected ranges. NK Technologies' original designs are refined to a wide range of application.

AS1 SERIES COMPACT CASE

AC Current Sensing Switches

The AS1 Series Compact Case Current Sensing Switches are compact and inexpensive. The easy-to-use ring slips onto the conductor to give a solid-state contact for indication of current flow. Ideal for use in control panels, or wherever confirmation of current flow is desired. AS1 Series-CC current sensing switches are a cost-effective way to detect live conductors and see current flow to fans, heaters, pumps, lighting or other AC powered devices.

Current Sensing Switch Applications

- Quick reporting of electric motor load status.
- Identify open heater circuit connection.
- Independent verification that the load is energized.
- Confirmation of operation for critical lighting or equipment.
- Low off state leakage is perfect for use as an input to a programmable logic controller.

Current Sensing Switch Features

Low Sensitivity Turn-on Point

- Detect currents as low as 0.5 A with a single conductor pass; eliminates the need to wrap conductors multiple times to increase sensitivity.

Reliable Solid-state Output

- No moving parts provides a nearly unlimited number of operations; powered from the monitored circuit.

Choice of Outputs

- Normally Open or Normally Closed connection. Connect the 24" long leads to a local controller or to a terminal block for remote operation.

UL/cUL and CE Approved

- Accepted worldwide.

Current Sensing Switch Dimensions

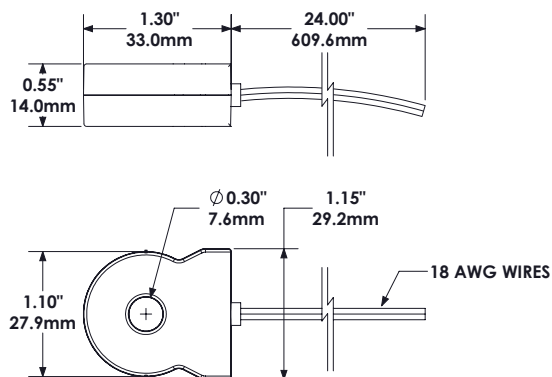

- For additional Application Examples, go to www.nktechnologies.com/applications



Current Sensing Switch Specifications



| | |
|---------------------------|---|
| Power Supply | None, self-powered |
| Setpoint Range | 0.5 A (factory set) |
| Output Description | Isolated solid-state relay |
| Output Rating | • 0.2 A @ 120 VAC/DC (N.O.) • 0.15 A @ 135 VAC/DC (N.C.) |
| Off-state Leakage | <10 μ A |
| Response Time | 120 ms |
| Time Delay | None |
| Hysteresis | 5% |
| Overload | 6 sec. @ 500 A, 1 sec. @ 1000 A |
| Isolation Voltage | UL listed to 1270 VAC, tested to 5 KV |
| Frequency Range | 50–400 Hz |
| Case | UL94 V-0 Flammability Rated |
| Environmental | -4 to 122°F (-20 to 50°C) 0–95% RH, non-condensing |
| Listings | UL /cUL, CE |

Current Sensing Switch Ordering Information

Sample Model Number: AS1-NOU-CC

AC current sensing switch, normally open, solid-core, compact case.

AS1 – (1) (2) – C C

(1) Output Rating

| | |
|-----|-----------------|
| NOU | Normally Open |
| NCU | Normally Closed |

(2) Case Style

| | |
|----|--------------|
| CC | Compact case |
|----|--------------|

OEMs Test & Evaluation Units for OEMs
Free program expedites evaluation process. See page 3 for details.

ASL SERIES

Linear Adjustment Setpoint Switches

The ASL Series Current Sensing Switches provide a current operated solid-state contact powered from the monitored circuit. The trip point adjustment uses a single turn potentiometer. By turning the adjustment arrow to the current magnitude needed, the installer can set the point where the output changes state when the monitored circuit is not energized. With the split-core case option, installation is just a matter of placing the sensor over the conductor. It couldn't be easier.

Features Patented Linear Setpoint Adjustment
US Patent 9766273



Current Sensing Switch Applications

AC Motor Loads

- Set a normally open contact over the normal running current level and it will open if the drive belt breaks or comes off the sheaves.
- Set a normally closed contact below the normal run current level and it will open on overload conditions.
- Monitor up to 150 A loads.

Critical Lighting Loads

- Monitor security lighting and water navigational indicators.

Heating Loads

- Receive independent verification that an element is working properly.
- Monitor drying and curing processes remotely.

Current Sensing Switch Features

Easily Established Contact Actuation Point

- Patented potentiometer setpoint selection.
- Trip point indicated on the labeling.
- Trip point can be set without energizing the monitored load, adding a large measure of safety.
- Two-second delay before contact action upon initial energization allows the output to ignore motor inrush current.

Isolation

- Output is magnetically isolated from the input for safety.
- Eliminates insertion losses, no added burden.

Solid-state Reliability

- No moving components for switching.
- No need for periodic maintenance or calibration.

Panel Mounted Solid- or Split-core Case

- Split-core case allows installation without disturbing existing wiring and can be mounted in any position. Either case can be attached to a panel, hung on the conductor or on a DIN rail adapter (included).*
- Both solid- or split-core cases provide windows large enough for 150 A loads, non-contact design provides complete isolation between monitored load and control circuitry.

No External Power Needed

- Sensor is powered from the monitored AC circuit.
- Choose normally open (closing on current increase) or normally closed (opening on current increase).
- Fast action contact reacts quicker than RTD, thermocouples, or bimetallic thermal elements.

UL/cUL and CE Approved

- Accepted worldwide.

*For information on the DIN rail accessories kit, see page 147.

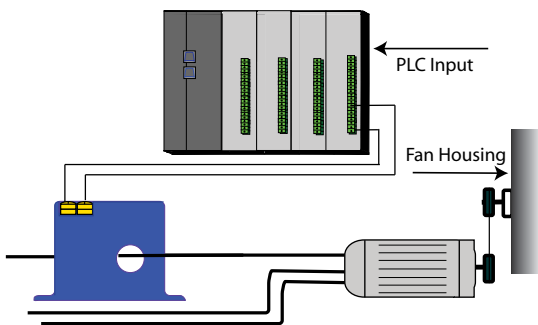

Motor current causes the solid-state contact to close, and if the coupling or drive belt breaks, the current falls and the sensor output opens again.

OEMs Test & Evaluation Units for OEMs
Free program expedites evaluation process. See page 3 for details.

Current Sensing Switch Dimensions

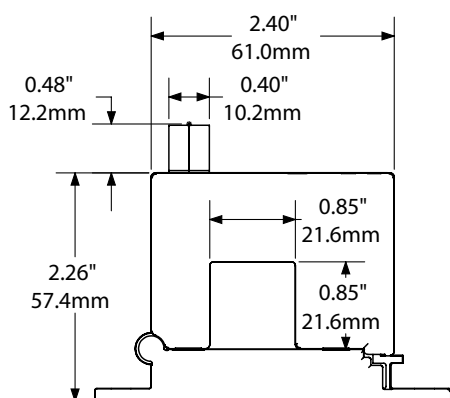
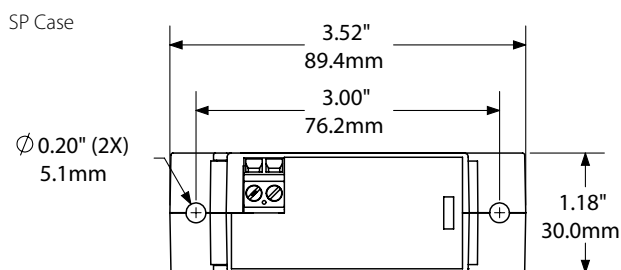
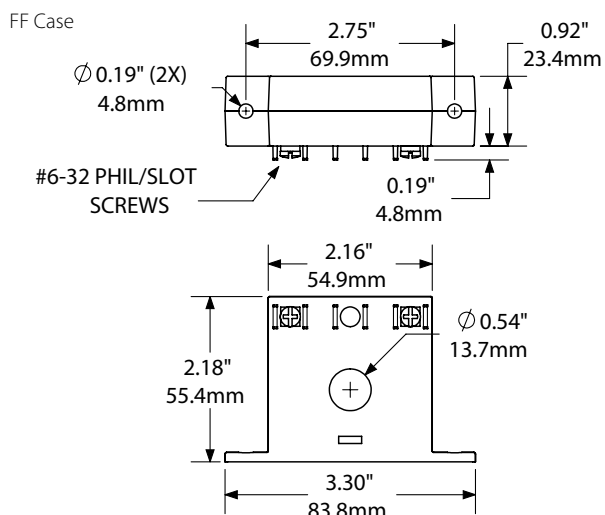

Current Sensing Switch Connections

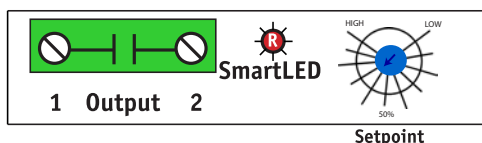

Notes:

- Zinc plated screw terminals solid-core case.
- Deadfront enclosed terminals split-core case.
- 14-22 AWG solid or stranded.
- Not polarity sensitive.

Current Sensing Switch Specifications



| | |
|--------------------------|---|
| Power Supply | None, self-powered |
| Input Range | 1–150 A (adjustable) |
| Output Switch | Isolated solid-state switch (AC/DC) |
| Output Rating | <ul style="list-style-type: none"> • 150 mA @ 240 VAC/VDC N.O. • 200 mA @ 135 VAC/VDC N.C. (General use only) |
| Response Time | 100 ms |
| Time Delay | 2 seconds on initial energization |
| Isolation Voltage | UL listed to 1480 VAC |
| Hysteresis | Minimum 3% of Setpoint |
| Frequency Range | 10–100 Hz |
| Case | UL94 V-0 Flammability Rated |
| Environmental | -4 to 122°F (-20 to 50°C) 0–95% RH, non-condensing |
| Listings | UL/cUL, CE |

Current Sensing Switch Output Type

Normally open universal AC or DC solid-state contact, 150 mA to 240 V (maximum load across output contact) or normally closed universal AC or DC solid-state contact, 200 mA to 135 V (maximum load across output contact).

Current Sensing Switch Ordering Information

Sample Model Number: ASL1-NOU-FF
 Solid-core AC current sensing switch with single turn setpoint adjustment normally open, Smart LED standard. (DIN rail adapters are included)

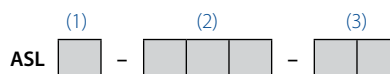

(1) Full Scale Range

| | |
|---|---|
| 1 | 1–10 A (solid-core) 2–20 A (split-core) |
| 2 | 10–50 A (solid-core) 20–50 A (split-core) |
| 3 | 50–100 A |
| 4 | 100–150 A |

(2) Output Type

| | |
|-----|-----------------|
| NOU | Normally Open |
| NCU | Normally Closed |

(3) Case Style

| | |
|----|-----------------------------|
| FF | Solid-core, front terminals |
| SP | Split-core |



ASM SERIES

Self-calibrating Current Sensing Smart Switches

The patented design of the ASM Series Self-calibrating Smart-Switch is more accurate and easier to use than previous models. This Smart-Switch uses the actual load current to set the trip point. It takes just a couple of seconds of steady running conditions before the sensor locks onto the normal current level. The ASM Series is designed for overload, underload or operating window applications. Upon sensing an average operating current, the ASM self-learns and establishes a limit-alarm trip point based on 85–125% of normal current (overload/underload model only). Available in a solid- or split-core case.



US Patent 8698426

Current Sensing Switch Applications

Conveyors (-OL Option)

- Detects jams and overloads.
- Interlocks multiple conveyor sections.

Electronic Proof of Flow (-UL Option)

- More reliable than electromechanical pressure or flow switches. No need for pipe or duct penetrations.

Pump Protection (-OU Option)

- Provides overload (jams) and underload (suction loss) indication.
- Interlocks multiple conveyor sections.

Current Sensing Switch Features

Self-powered and Self-calibrating

- Speeds startup, cuts installation costs.

Status Monitoring, Overload, and Operating Window Options

- Choose the operating style that matches your application.

Universal Output

- AC or DC compatibility with any automation system.

UL/cUL and CE Approved

- Accepted worldwide.

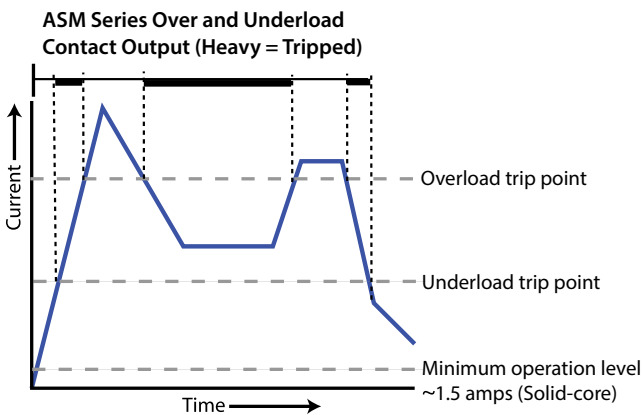

For additional Application Examples, go to www.nktechnologies.com/applications

OEMs

Test & Evaluation Units for OEMs

Free program expedites evaluation process. See page 3 for details.

Current Sensing Switch Dimensions

FT Case

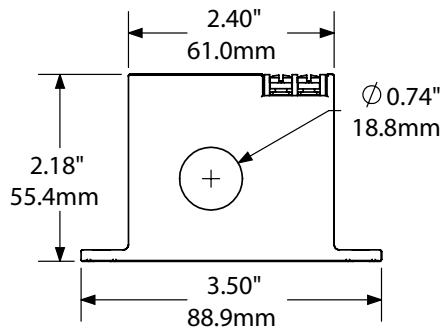
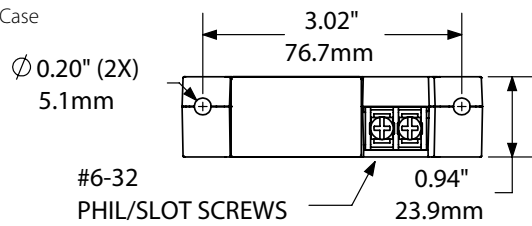

SP Case

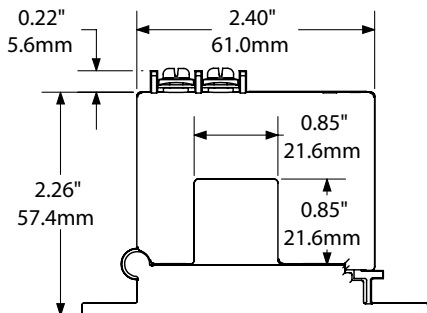
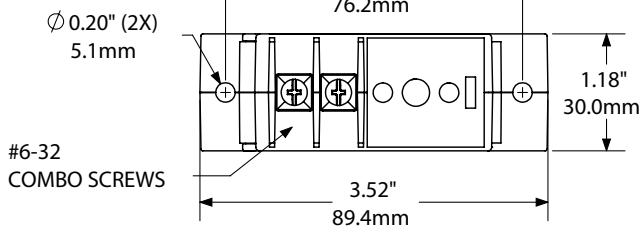

Current Sensing Switch Specifications



| | |
|-----------------------------|--|
| Power Supply | None, self-powered |
| Setpoint Range | • Solid-core: 1.5–150 A (self-calibrating) • Split-core: 2.8–150 A (self-calibrating) |
| Output Switch | Isolated solid-state switch |
| Setpoint Calibration | Output changes with AC current between 85% and 125% of normal running current |
| Output Rating | • N.O. Version: 0.30 A @ 135 VAC/VDC • N.C. Version: 0.20 A @ 135 VAC/VDC • Not polarity sensitive |
| Off-state Leakage | <10 μ A |
| Response Time | 200 ms |
| Time Delay | None |
| Hysteresis | 5% |
| Overload | 500 A @ 6 sec., 1000 A @ 1 sec. |
| Isolation Voltage | UL listed to 1270 VAC |
| Frequency Range | 6–100 Hz |
| Case | UL94 V-0 Flammability Rated |
| Environmental | -4 to 122°F (-20 to 50°C) 0–95% RH, non-condensing |
| Listings | UL/cUL, CE |

Current Sensing Switches

Current Sensing Switch Ordering Information

Sample Model Number: ASM-NOU-OL-SP
AC current sensing switch, normally open, self-calibrating overload operation in a split-core case. (DIN rail adapters are included)



(1) Output Rating

| | |
|-----|-----------------|
| NOU | Normally Open |
| NCU | Normally Closed |

(2) Operation

| | |
|----|----------------|
| OL | Overload |
| UL | Underload |
| OU | Over/underload |

(3) Case Style

| | |
|----|---------------------------|
| FT | Solid-core, top terminals |
| SP | Split-core |



ASC SERIES

Factory-calibrated Current Operated Switches

ASC Series Current Sensing Switches are precision calibrated at the factory per customers' specifications and guaranteed within 1% accuracy. Because the switch is factory calibrated eliminating the need to turn the potentiometer to the correct position in the field, installation time is substantially reduced resulting in a significant cost savings. The ASC combines a current transformer, signal conditioner and limit alarm into a single package for use in status monitoring or proof of operation applications and is perfect for OEM applications where the need for a limit alarm is required. Available in a solid-core or a split-core case to maximize ease of installation.

Current Sensing Switch Applications

Electronic Proof of Flow

- Current operated switches eliminate the need for multiple pipe or duct penetrations and are more reliable than electromechanical pressure or flow switches.

Conveyors

- Detects jams and overloads.
- Interlocks multiple conveyor sections.

Lighting Circuits

- Easier to install and more accurate than photocells.

Electrical Heaters

- Faster response than temperature sensors.

Air Handling Fan Protection

Factory-set trip points are ideal when there are several loads, all using the same motor to drive the fan blades.

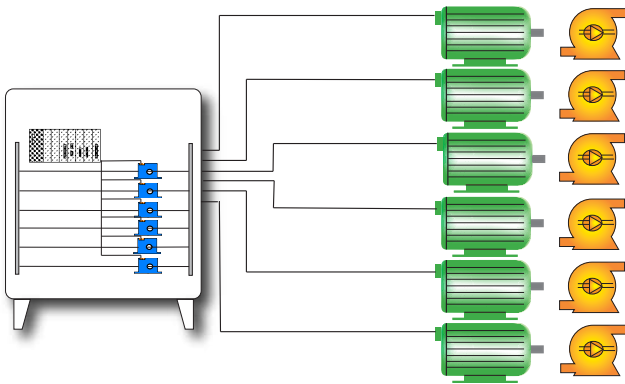

- For additional Application Examples, go to www.nktechnologies.com/applications

OEMs

Test & Evaluation Units for OEMs

Free program expedites evaluation process. See page 3 for details.



US Patent 8698426

Current Sensing Switch Features

Universal Output

- N.O. or N.C. solid-state switch for control circuits up to 135 VAC/DC.
- Compatible with most automation systems.

Self-powered

- Cuts installation and operating costs.

Precision-calibrated Factory Set Trip Point

- Speeds startup.
- Improves safety.

Solid- or Split-core Case

- Versions tailored for each installation.

LED Indication

- Provides quick visual indication of contact status.

Built-in Mounting Feet

- Simple, two-screw panel mounting or attach with DIN rail adapters (included).*

Designed for UL/cUL and CE Approval

- Accepted worldwide.

*For information on the DIN rail accessories kit, see page 147.

Current Sensing Switch Dimensions

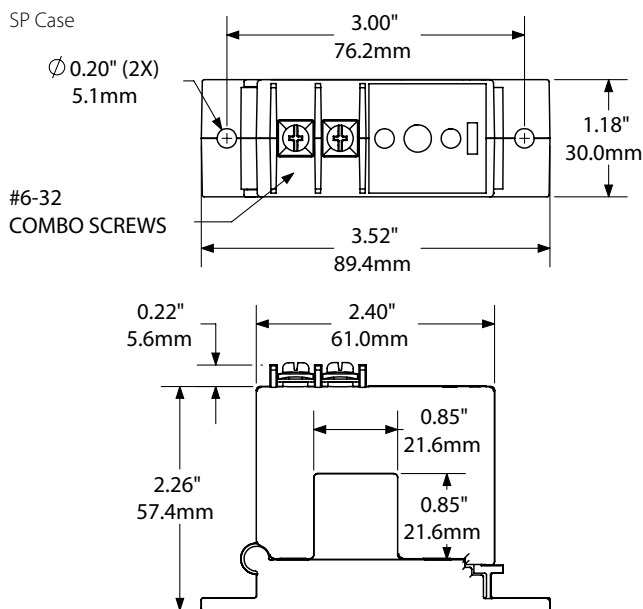
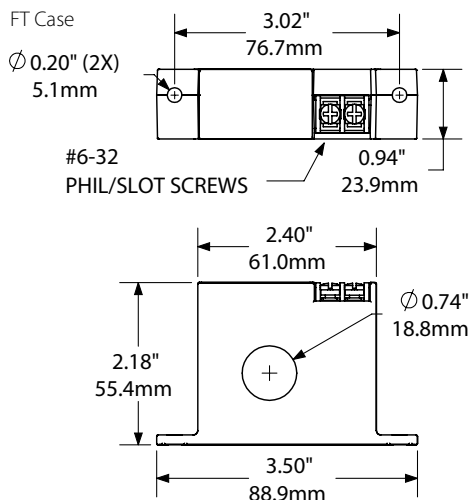

Current Sensing Switch Connections

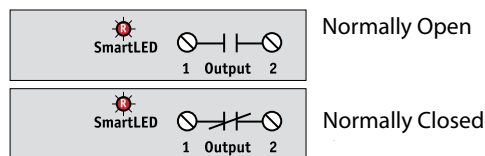

Current Sensing Switch Specifications

| | |
|--------------------------|--|
| Power Supply | None, self-powered |
| Setpoint Range | • Solid-core: 2–150 A (factory set) • Split-core: 3–150 A (factory set) |
| Output Switch | Isolated solid-state switch |
| Output Rating | • N.O. Version: 0.3 A @ 135 VAC or VDC • N.C. Version: 0.2 A @ 135 VAC or VDC • Not polarity sensitive |
| Off-state Leakage | <10 µA |
| Response Time | 120 ms |
| Time Delay | None |
| Hysteresis | 5% |
| Overload | 400 A @ 6 sec., 1000 A @ 1 sec. |
| Isolation Voltage | Tested to 1270 VAC |
| Frequency | 50 or 60 Hz |
| Case | UL94 V-0 Flammability Rated |
| Environmental | -4 to 122°F (-20 to 50°C) 0–95% RH, non-condensing |
| Listings | Designed for UL/cUL and CE approval |

Current Sensing Switch Ordering Information

Sample Model Number: ASC-NOU-6-SP-090
 Factory set AC current operated switch, normally open, 60 Hz frequency, split-core case, 90 A trip point. (DIN rail adapters are included)

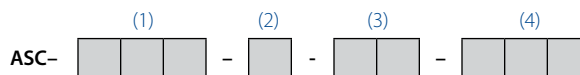

(1) Output Rating

| | |
|-----|-----------------|
| NOU | Normally Open |
| NCU | Normally Closed |

(2) Primary Circuit Frequency

| | |
|---|-------|
| 6 | 60 Hz |
| 5 | 50 Hz |

(3) Case Style

| | |
|----|--------------------------|
| FT | Solid-core, top terminal |
| SP | Split-core |

(4) Factory Set Trip Point

| | |
|------------|--|
| 002 to 150 | Solid-core model factory-set trip point in amps. |
| 003 to 150 | Split-core model factory-set trip point in amps. |



ASD SERIES

Current Sensing Switches

ASD Series Current Sensing Switches provide a limit alarm contact with the easiest adjustment method ever designed. The single turn potentiometer allows the trip point to be set before the sensor is installed, or before the monitored circuit is energized. The LED display provides a quick visual indication of where the contact changes.



Features a single turn potentiometer and LED display
US Patent 9747776

Current Sensing Switch Applications

Electronic Proof of Operation

- Current operated switches eliminate the need for multiple pipe or duct penetrations and are more reliable than electromechanical pressure or flow switches.

Conveyors

- Detects jams and overloads.
- Interlocks multiple conveyor sections.

Pump Control

- Output contact is adjusted so it is closed during normal operation, opening if the pump runs dry or there is a loss of head pressure for any reason.

Cooling Towers

- Monitor for overcurrent conditions caused by open duct access doors or undercurrent from a broken drive belt or coupling.

Conveyor Protection

If the conveyor jams, the solid-state contact opens to stop the infeed or drive motor.

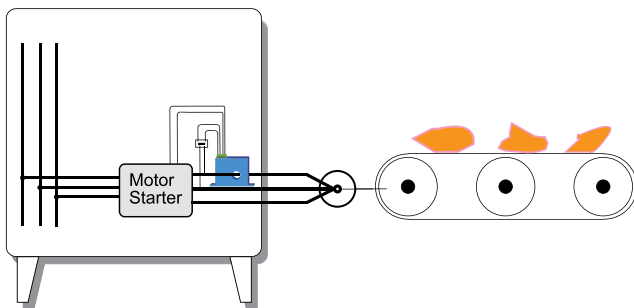

- For additional Application Examples, go to www.nktechnologies.com/applications

OEMs

Test & Evaluation Units for OEMs

Free program expedites evaluation process. See page 3 for details.

Current Sensing Switch Features

Solid-state Output

- N.O. or N.C. solid-state switch for control circuits up to 240 VAC.
- Compatible with most automation systems.

External Powered

- Allows for higher accuracy.

Easily Adjustable and Precise Setpoint

- Speeds startup.
- Improves the safety by allowing the trip point adjustment with no power through the sensing window.

LED Display

- Provides quick visual indication of where the contact changes. When current exceeds the setpoint, the display flashes on and off.
- Easiest and most accurate setpoint adjustment available.

Built-in Mounting Feet

- Simple, two-screw panel mounting or attach with DIN rail adapters (included).*

UL/cUL and CE Approved

- Accepted worldwide.

*For information on the DIN rail accessories kit, see page 147.

Current Sensing Switch Dimensions

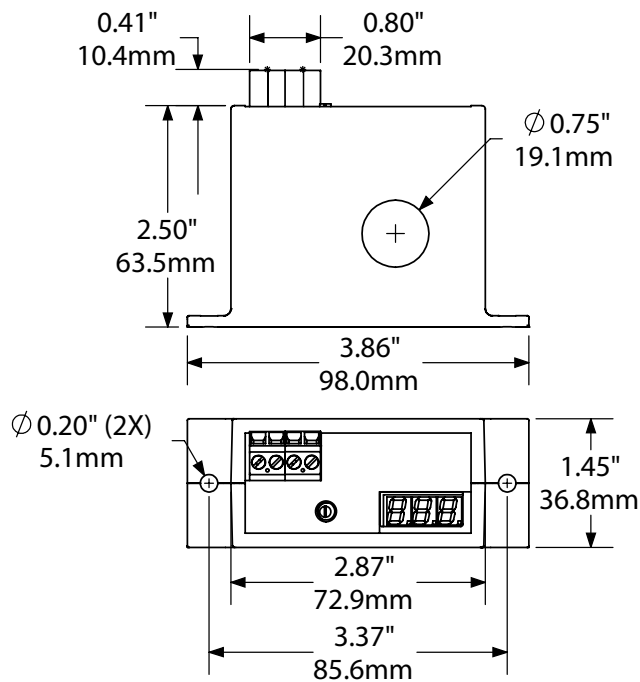

Current Sensing Switch Specifications



| | |
|--------------------------|--|
| Power Supply | 24 VAC/VDC (18–28 V) |
| Power Consumption | 160 mA |
| Setpoint Range | • ASD1: 1–50 A (adjustable) • ASD2: 4–200 A (adjustable) |
| Output Switch | Isolated solid-state switch |
| Output Rating | Max.: 1.0 A @ 240 VAC (general use) |
| Off-state Leakage | • <10 µA normally open • 2.5 mA normally closed |
| Response Time | 500 ms 5% over setpoint 200 ms 50% over setpoint 150 ms 100% over setpoint |
| Hysteresis | 5% |
| Isolation Voltage | Tested to 1480 VAC |
| Frequency Range | 40–100 Hz |
| Case | UL94 V-0 Flammability Rated |
| Environmental | -4 to 122°F (-20 to 50°C) Surrounding Air 0–95% RH, non-condensing |
| Listings | UL/cUL, CE |

Current Sensing Switch Connections

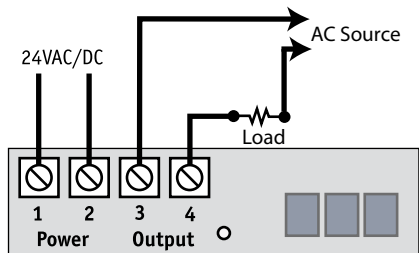

Display shows trip point in amps
so 15 A displays 015.

Current Sensing Switch Ordering Information

Sample Model Number: ASD1-NOAC-24U-FL
Adjustable AC current operated switch, normally open, solid-core case.
(DIN rail adapters are included)

ASD (1) - (2) - (3) 2 4 U - (4) F L

(1) Range

| | |
|---|---------------------------|
| 1 | 1–50 A switch adjustment |
| 2 | 4–200 A switch adjustment |

(2) Output Contact

| | |
|------|---|
| NOAC | Normally Open, closes on current rise, AC control only |
| NCAC | Normally Closed, opens on current rise, AC control only |

(3) Power Supply

| | |
|-----|---------------|
| 24U | 24 VAC or VDC |
|-----|---------------|

(4) Case Style

| | |
|----|------------|
| FL | Solid-core |
|----|------------|



AS0 SERIES

Current Sensing Switches

AS0 Series Current Sensing Switches are designed to detect very low AC current, and provide a solid-state contact to open or close at a setpoint adjustable from 3 to 350 mA across two ranges. Useful for signal or lamp status monitoring, detecting low level fault currents or fan status proofing, the AS0 Series features solid-state outputs and jumper-selectable ranges, which make it a versatile choice for low-current status indication applications.



Current Sensing Switch Applications

Fan Monitoring

- Fan status in heating and drying applications.
- Identify lamp outages or other malfunctions through changes in current consumption.

Fractional HP Motors

- Ideal for monitoring small motors used in critical applications, for example, fan status proofing on a crucial cooling fan.

LED Lamp Operation

- Switch can detect LED light sources drawing less than one half watt at 120 VAC.

Current Sensing Switch Features

Wide Range of Output Options

- Dependable, solid-state relay N.O. or N.C. contacts rated at 240 VAC or 30 VDC.
- Compatible with most automation controllers.

Isolated Inputs and Outputs

- Inductive sensing eliminates insertion loads on monitored circuits, effectively isolating it from the unit.
- Isolated outputs simplify wiring and enhance safety.

Adjustable Setpoints

- Setpoints are field-adjustable from 3 mA to 350 mA, speeding installation and allowing for tailored applications.

UL/cUL and CE Approved

- Accepted worldwide.

Status Alarming

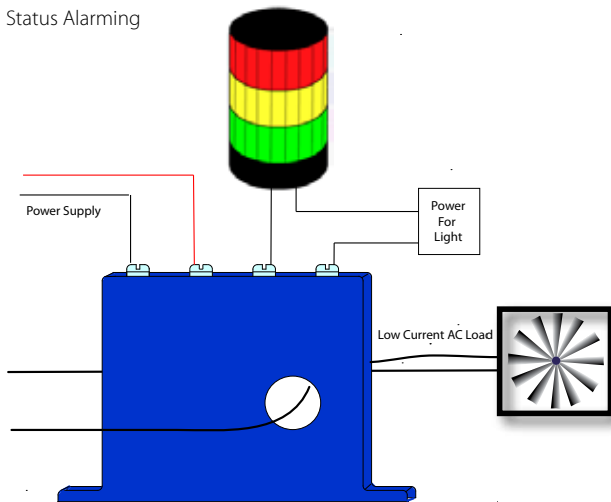

- For additional Application Examples, go to www.nktechnologies.com/applications

OEMs

Test & Evaluation Units for OEMs

Free program expedites evaluation process. See page 3 for details.

Current Sensing Switch Dimensions

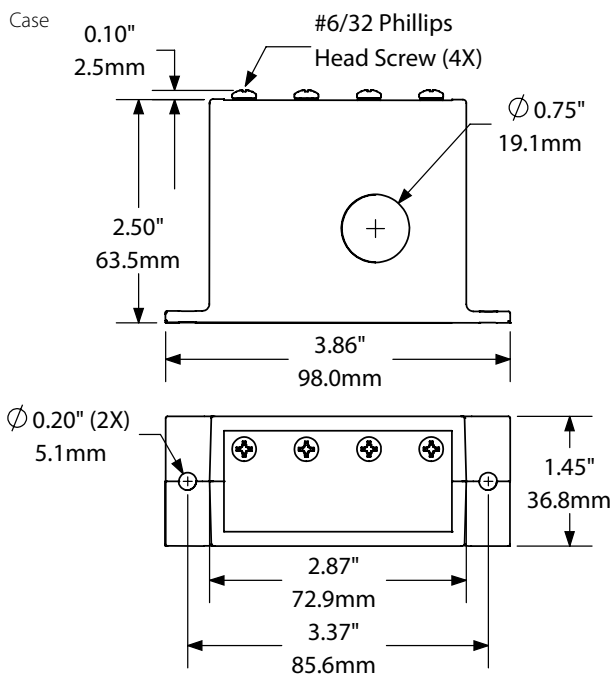

Current Sensing Switch Specifications



| | |
|--------------------------|---|
| Power Supply | • 120 VAC (96–144 V) • 24 VAC/VDC (19–29 V) |
| Power Consumption | 2.5 VA |
| Setpoint Range | • Low Range: 3–15 mA (adjustable) • High Range: 15–350 mA (adjustable) |
| Input | 10 A max. |
| Output Rating | • AC Version: 1 A @ 240 VAC • DC Version: 0.15 A @ 30 VDC |
| Response Time | • 150 ms @ 5% above setpoint • 100 ms @ 50% above setpoint |
| Time Delay | None |
| Hysteresis | <5% |
| Overload | 10 A continuous |
| Isolation Voltage | 1480 VAC, tested to 5 KV |
| Frequency Range | 50–400 Hz |
| Case | UL94 V-0 Flammability Rated |
| Environmental | -4 to 122°F (-20 to 50°C) 0–95% RH, non-condensing |
| Listings | UL/cUL, CE |

Current Sensing Switches

Current Sensing Switch Connections

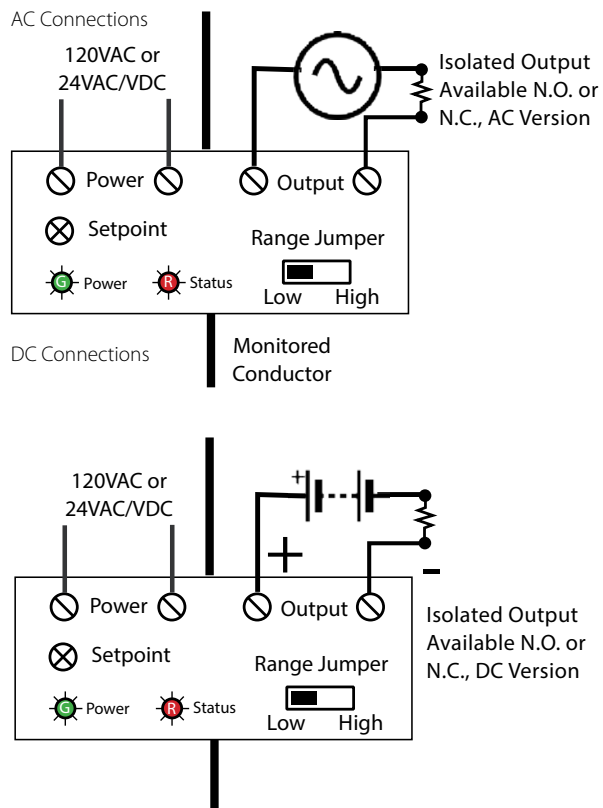

Current Sensing Switch Ordering Information

Sample Model Number: AS0-NODC-120
Ultra low current sensing switch, normally open solid-state DC output and 120 VAC power supply. (DIN rail adapters are included)

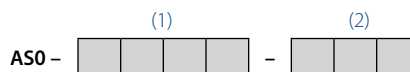

(1) Output Type

| | |
|------|----------------------------------|
| NCAC | Normally Closed, 1 A @ 240 VAC |
| NOAC | Normally Open, 1 A @ 240 VAC |
| NCDC | Normally Closed, 0.15 A @ 30 VDC |
| NODC | Normally Open, 0.15 A @ 30 VDC |

(2) Power Supply

| | |
|-----|------------|
| 24U | 24 VAC/VDC |
| 120 | 120 VAC |

Notes:

- Terminals are #6 screws.
- Use up to 22-14 AWG solid or stranded.
- Power connections are not polarity sensitive.
- DC output connections are polarity sensitive.



ASX SERIES

Current Sensing Switches

ASX Series Current Sensing Switches are high performance current sensing switches with field-adjustable time delay to help minimize nuisance trips during startup and operation. Designed for motor status applications where setpoint accuracy and repeatability are critical, the ASX Series offers a linear setpoint characteristic and constant hysteresis. Standard features include self-powering, jumper-selectable ranges and a choice of outputs and cases.



Current Sensing Switch Applications

Motor Protection

- Serves as an electronic proof-of-operation; detects current draw changes in motors when they encounter problems such as pumps running dry or pending bearing failure.
- Non-intrusive, less expensive to install than differential pressure flow sensors or thermal switches.
- Much quicker response time than Class 10 overload switches.

High Inrush or Temporary Overload Current

- Adjustable startup/delay timer allows 0.12–15 second delay to eliminate nuisance trips from high inrush or short overload conditions.

Isolated Alarm System Interfacing

Detect dead head conditions in a pump system

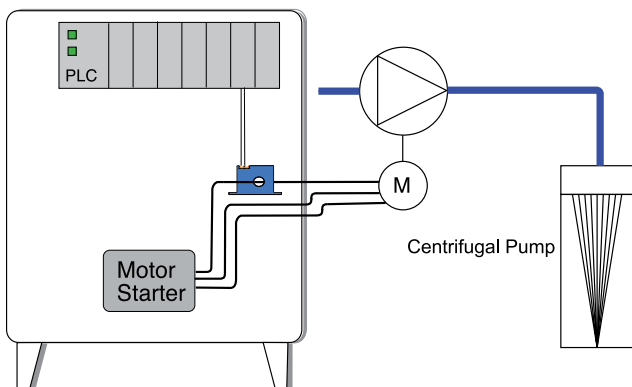

- For additional Application Examples, go to www.nktechnologies.com/applications

OEMs

Test & Evaluation Units for OEMs

Free program expedites evaluation process. See page 3 for details.

Current Sensing Switch Features

Adjustable Startup/Delay Timer

- Field-adjustable from 0.12 to 15 seconds to eliminate nuisance alarms due to startup inrush or temporary overcurrent conditions.

Choice of N.O./N.C. AC or Universal Outputs

- Contact ratings of 1.0 A @ 240 VAC or universal outputs of 0.15 A @ 240 VAC/DC (N.O. models) and 0.2 A @ 135 VAC/DC (N.C. models) for use with most standard motor control systems.

Improved Ease of Installation and Use

- 1.0 A AC rating eliminates need for time delay relay.
- Self-powered, split-core models simplify installation.
- Status LED provides visual indication of setpoint trip and contact action.

Industrial Grade Performance

- Constant hysteresis, linear response characteristics enhance setpoint accuracy.

UL/cUL and CE Approved

- Accepted worldwide.

Current Sensing Switch Dimensions

FT Case

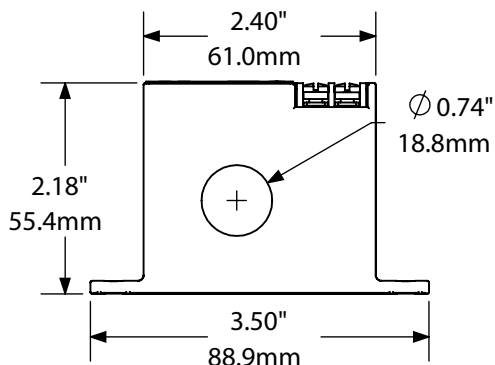
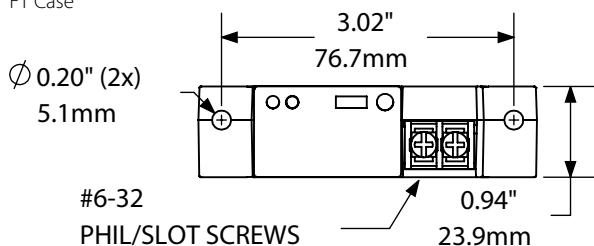

SP Case

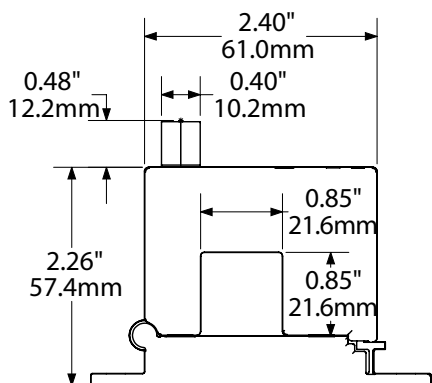
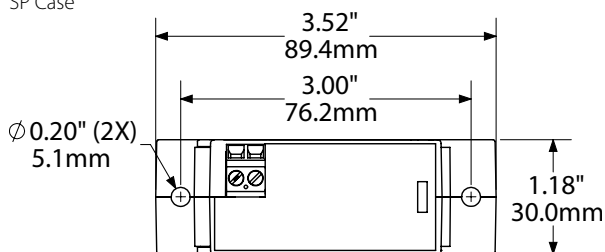

Current Sensing Switch Connections

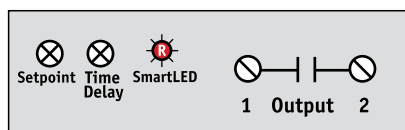

Current Sensing Switch Specifications



| | | | | | | | | | | | | | |
|--------------------------|--|---------|------------|--------|--------|-----|---------|---------|----------|-----|---------|---------|----------|
| Power Supply | None, self-powered | | | | | | | | | | | | |
| Setpoint Range | -FT: 1.5-12, 12-55 and 50-175 A -SP: 2-12, 12-55 and 50-200 A | | | | | | | | | | | | |
| Output Switch | Isolated solid-state switch | | | | | | | | | | | | |
| Output Rating | • NOAC/NCAC: 1 A @ 240 VAC (general use) • NOU: 0.15 A @ 240 VAC or VDC (general use) • NCU: 0.2 A @ 135 VAC or VDC (general use) | | | | | | | | | | | | |
| Off-state Leakage | NOU, NCU & NOAC versions: <10 uA NCAC versions: 2.5 mA | | | | | | | | | | | | |
| Response Time | 0.12–15 sec. adjustable | | | | | | | | | | | | |
| Hysteresis | 5% | | | | | | | | | | | | |
| Overload | <table border="1"> <tr> <td></td> <td>CONTINUOUS</td> <td>6 SEC.</td> <td>1 SEC.</td> </tr> <tr> <td>-FT</td> <td>• 175 A</td> <td>• 400 A</td> <td>• 1000 A</td> </tr> <tr> <td>-SP</td> <td>• 200 A</td> <td>• 400 A</td> <td>• 1000 A</td> </tr> </table> | | CONTINUOUS | 6 SEC. | 1 SEC. | -FT | • 175 A | • 400 A | • 1000 A | -SP | • 200 A | • 400 A | • 1000 A |
| | CONTINUOUS | 6 SEC. | 1 SEC. | | | | | | | | | | |
| -FT | • 175 A | • 400 A | • 1000 A | | | | | | | | | | |
| -SP | • 200 A | • 400 A | • 1000 A | | | | | | | | | | |
| Isolation Voltage | UL listed to 1480 VAC | | | | | | | | | | | | |
| Frequency Range | 50–100 Hz | | | | | | | | | | | | |
| Case | UL94 V-0 Flammability Rated | | | | | | | | | | | | |
| Environmental | 5 to 122°F (-15 to 50°C) 0–95% RH, non-condensing | | | | | | | | | | | | |
| Listings | UL/cUL, CE | | | | | | | | | | | | |

Current Sensing Switch Ordering Information

Sample Model Number: ASX-NOAC-SP
Current sensing switch with adjustable time delay, N.O. 1.0 A @ 240 VAC output, jumper-selectable input ranges, split-core case. (DIN rail adapters are included)

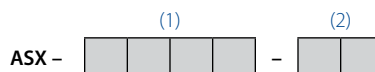

(1) Output Type

| | |
|------|-------------------------------------|
| NOAC | Normally Open, 1 A @ 240 VAC |
| NCAC | Normally Closed, 1 A @ 240 VAC |
| NOU | Normally Open, 0.15 A @ 240 VAC/DC |
| NCU | Normally Closed, 0.2 A @ 135 VAC/DC |

(2) Case Style

| | |
|----|------------|
| FT | Solid-core |
| SP | Split-core |



Current Sensing Switch Dimensions

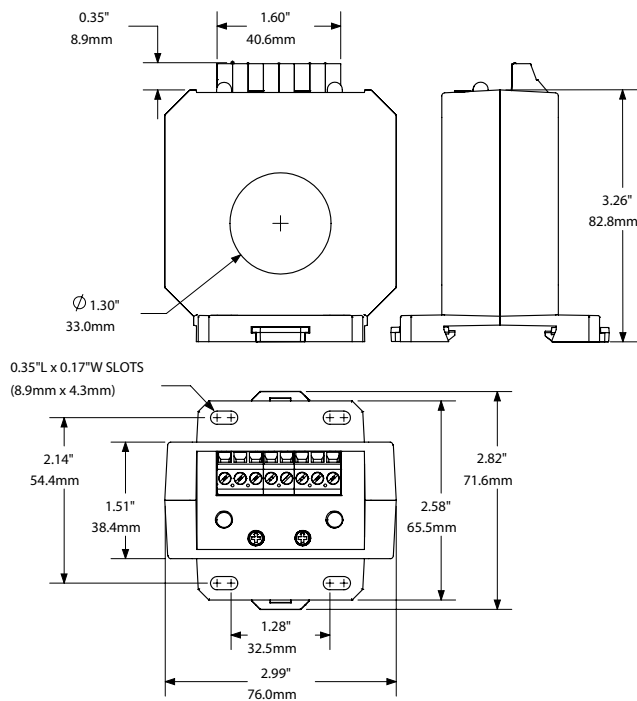

Current Sensing Switch Specifications



| | |
|--------------------------|---|
| Power Supply | 24 VAC/VDC (22-26 V) |
| Power Consumption | <2 VA |
| Output Switch | Dual single pole, double throw relays |
| Output Rating | Maximums: 1.0 A up to 120 VAC 2A to 30 VDC (general use) |
| Off-State Leakage | None |
| Response Time | 40–120 ms |
| Setpoint Ranges | ASP1: 1–20 A ASP2: 2–35 A ASP3: 4–65 A ASP4: 8–120 A ASP5: 15–220 A ASP6: 25–400 A |
| Hysteresis | 4% of setpoint |
| Overload | 6 sec: 3 x range 1 sec: 5 x range |
| Isolation Voltage | Tested to 1240 VAC |
| Frequency Range | 40–65 Hz |
| Case | UL94 V-0 Flammability Rated |
| Environmental | -4 to 122°F (-20 to 50°C) Surrounding Air 0–95% RH, non-condensing |
| Listings | UL/cUL, CE |

Current Sensing Switches

Current Sensing Switch Connections

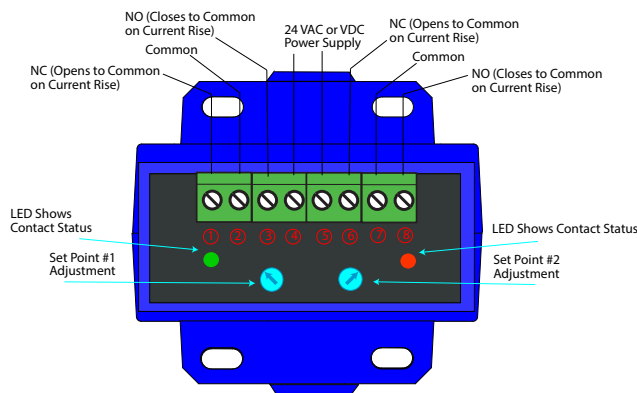

Current Sensing Switch Ordering Information

Sample Model Number: ASP1-DPT-24U-FD
Dual adjustable AC current operated relay, 1–20 A range, 24 VAC or DC power supply, solid-core case.



(1) Range

| | |
|---|----------|
| 1 | 1–20 A |
| 2 | 2–35 A |
| 3 | 4–65 A |
| 4 | 8–120 A |
| 5 | 15–220 A |
| 6 | 25–400 A |

(3) Output Contact

| | |
|-----|-----------------------------|
| DPT | Two independent SPDT relays |
|-----|-----------------------------|

(4) Power Supply

| | |
|-----|---------------|
| 24U | 24 VAC or VDC |
|-----|---------------|

(3) Case Style

| | |
|----|--|
| FD | Solid-core, DIN rail or panel mounting |
|----|--|



ASXP SERIES

Current Sensing Switches

ASXP Series Current Sensing Switches are powered versions of our popular current switches with integral time delay. A fixed two-second delay upon initial energization of monitored load minimizes nuisance alarms during startup and operation in motor or heater status applications. After startup a separate 0–20 second delay can be set. For use with 24 VAC/VDC or 120 VAC power supplies, this high performance product offers OEM-caliber accuracy, precision tolerances, low hysteresis and an operation range between 40 and 100 Hz. Available with status LED and solid-core case as standard.



Current Sensing Switch Applications

Motor Protection

- Serves as an electronic proof-of-operation; detects current draw changes in motors when they encounter problems such as pumps running dry or impending bearing failure.
- Non-intrusive, less expensive to install than differential pressure flow sensors or thermal switches.
- Much quicker response time than Class 10 overload switches.

High Inrush or Temporary Overload Current

- Factory-set two-second delay on startup eliminates nuisance trips from high inrush or short overload conditions. After startup, a second 0.2–20 second user-adjustable delay is available.

Safety Interlocks

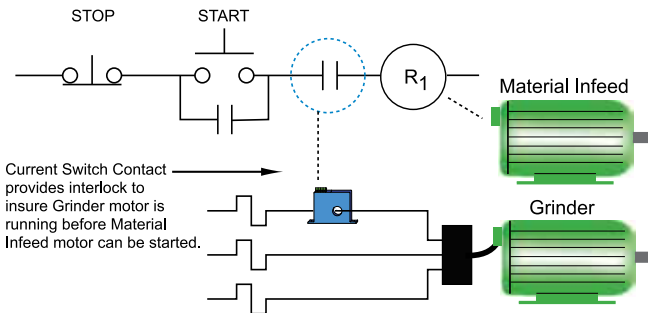

- For additional Application Examples, go to www.nktechnologies.com/applications

Current Sensing Switch Features

Fixed Startup/Delay Timer

- Factory-calibrated trip timer set to 2 seconds to eliminate nuisance alarms due to startup inrush or temporary overcurrent conditions.

Form C Electromechanical Relay Output

- Contact rating of 1 A, up to 120 VAC, provides adequate switching capacity for use with most motor control systems.

Improved Ease of Installation and Use

- Eliminates need for separate time delay relay.
- Choice of 24 VAC/VDC or 120 VAC power supply models.
- LED provides indication of trip point contact status.
- Setpoint adjustable from 1–80 A.

Industrial Grade Performance

- Repeatable performance, precise time delay setpoint, constant hysteresis and linear trip point adjustment.

UL/cUL and CE Approved

- Accepted worldwide.

OEMs Test & Evaluation Units for OEMs
Free program expedites evaluation process. See page 3 for details.

Current Sensing Switch Dimensions

FL Case

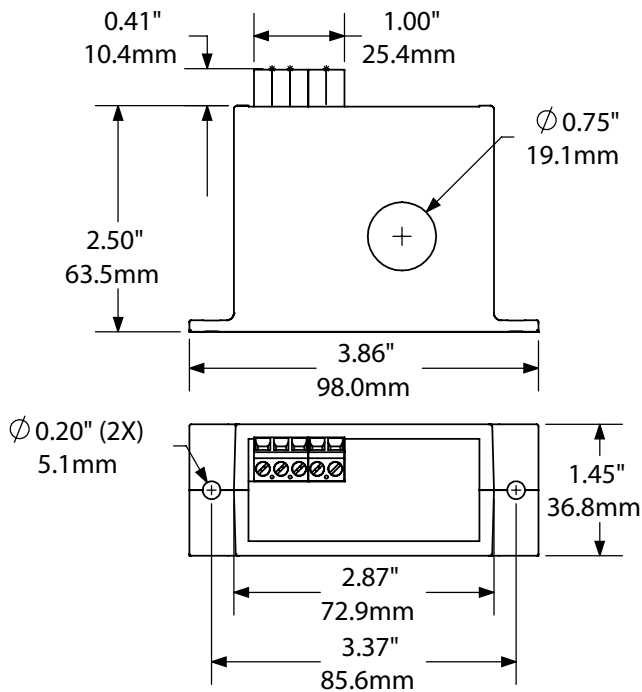

Current Sensing Switch Connections

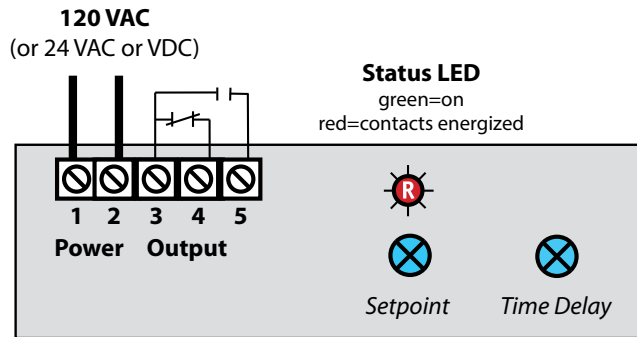

Current Sensing Switch Specifications



| | |
|--------------------------|--|
| Power Supply | • 120 VAC (108–136 V) • 24 VAC/VDC (22–26 V) |
| Power Consumption | <2 VA |
| Setpoint Range | • ASXP1: 1–20 A (adjustable) • ASXP2: 20–50 A (adjustable) • ASXP3: 50–80 A (adjustable) |
| Output Switch | Electromechanical SPDT relay |
| Output Rating | 1 A @ 120 VAC; 2 A @ 30 VDC (general use) |
| Time Delay | 2.0 sec. (fixed on startup) 0.2–20 sec. (adjustable after startup) |
| Hysteresis | 5% |
| Isolation Voltage | UL listed to 2200 VAC |
| Frequency Range | 40–100 Hz |
| Case | UL94 V-0 Flammability Rated |
| Environmental | -4 to 122°F (-20 to 50°C) 0–95% RH, non-condensing |
| Listings | UL/cUL, CE |

Current Sensing Switches

Current Sensing Switch Ordering Information

Sample Model Number: ASXP1-SDT-120-FL
AC current sensing switch, fixed 2 sec. delay, SPDT 1 A output, 120 VAC supply, solid-core case. (DIN rail adapters are included)



(1) Input Range

| | |
|---|---------|
| 1 | 1–20 A |
| 2 | 20–50 A |
| 3 | 50–80 A |

(2) Output Type

| | |
|-----|--------------------|
| SDT | SPDT 1 A @ 120 VAC |
|-----|--------------------|

(3) Power Supply

| | |
|-----|------------|
| 24U | 24 VAC/VDC |
| 120 | 120 VAC |

(4) Case Style

| | |
|----|------------|
| FL | Solid-core |
|----|------------|



ASXP-MS SERIES

Current Sensing Switches

ASXP-MS Series Current Switches combine a current transformer and signal conditioner into a single package. The large, easy-to-install split-core design allows for installation over existing conductors without the need to disconnect the load, even in applications where there are multiple conductors per phase. For new installations, the installation is just as easy. Just remove the top portion of the sensing ring, place the conductors inside, and snap the top back in place. The output relay energizes when the AC current through the sensing ring exceeds the adjustable setpoint, providing one contact to close and the other to open on current rise.

Current Sensing Switch Applications

Monitor Large Machines

- Detect over or undercurrent conditions before they cause break downs, or interlock one process with another.

Water Delivery and Treatment

- Detect open discharge lines.
- Sense clogged filters or blocked intake to pumps.

Generators

- Shed noncritical loads when demand reaches a set level.

Crusher Monitoring

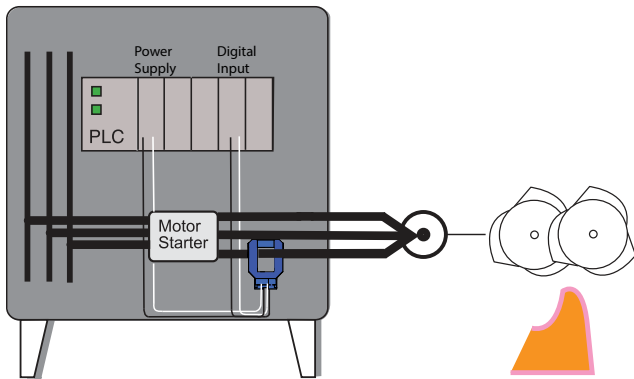

If the crusher drive draws too much current, the infeed belt can be stopped automatically, allowing the crusher to clear before restarting. The ASXP-MS provides a set of relay contacts for alarm of over or undercurrent conditions.

- For additional Application Examples, go to www.nktechnologies.com/applications

OEMs

Test & Evaluation Units for OEMs

Free program expedites evaluation process. See page 3 for details.



Current Sensing Switch Features

Electromechanical Relay Output

- Provides both normally open and normally closed contacts.
- Compatible with most automation and control systems.

Externally Powered

- Complete isolation between the sensor power and the controlled circuit.
- Provides a choice of failsafe* or standard operation.

Simple Field Setpoint Adjustment

- Single turn potentiometer with setpoint shown on label.
- Adjustable start delay to bypass inrush current.

Split-core Case

- Sensing window provides ample space for bus bar, single or multiple conductors.

DIN Rail** or Panel Mounted Case

- Simply snap onto DIN rail or attach with screws to a panel for secure mounting.

UL/cUL and CE Approved

- Accepted worldwide.

*For a description of failsafe operation, see the installation instructions.

**For information on the DIN rail accessories kit, see page 147.

Current Sensing Switch Connections

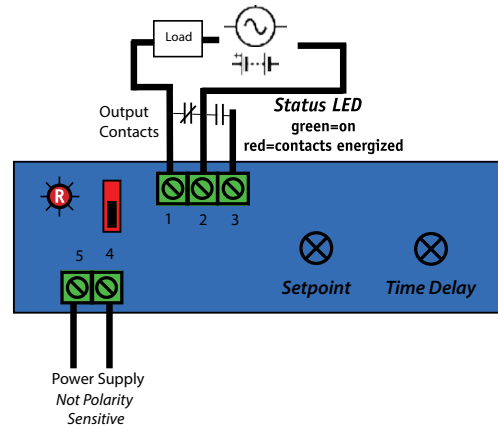

Current Sensing Switch Dimensions

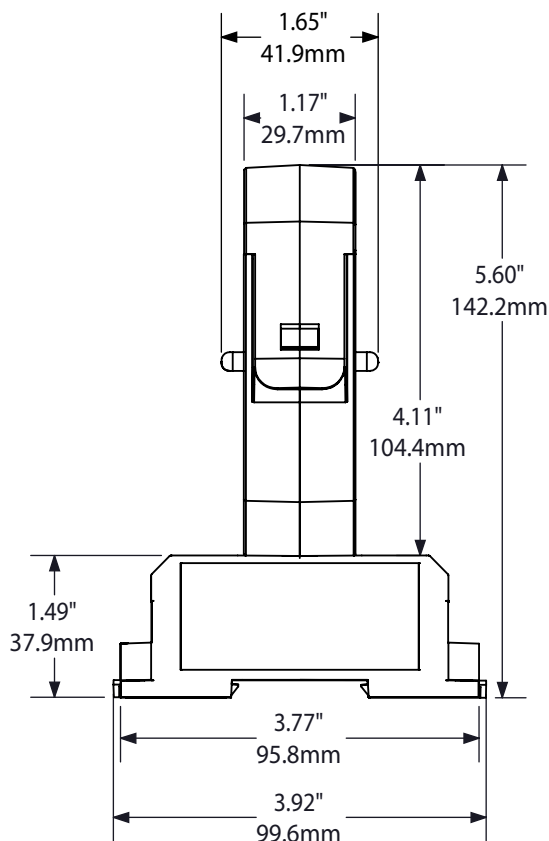
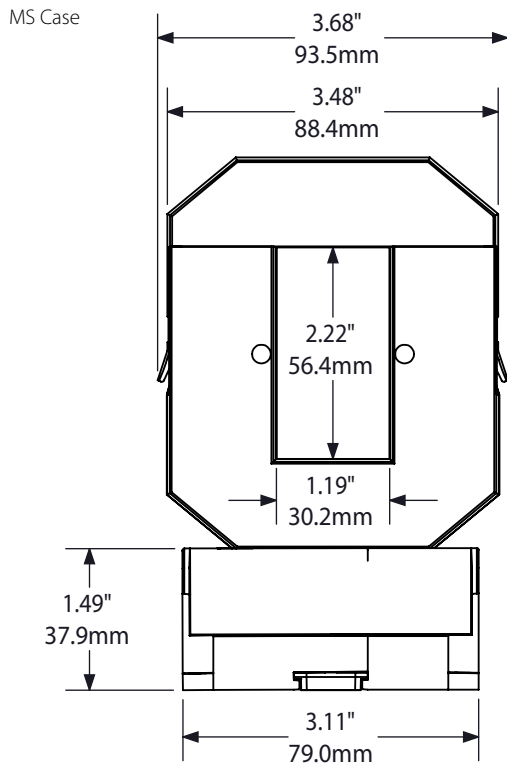

Current Sensing Switch Specifications



| | |
|--------------------------------|---|
| Power Supply | 120 VAC (108-132 V) or 24 VAC/VDC (22-28 V) |
| Power Consumption | <4 VA |
| Input Range | <ul style="list-style-type: none"> • 2: 50-200 A • 4: 100-400 A • 6: 150-600 A • 8: 200-800 A |
| Output Switch | Electromechanical SPDT relay |
| Output Rating | 1 A @ 120 VAC, 2 A @ 30 VDC max. |
| Indicating Bi-color LED | Green: Power on, current within range Red: Power on, current over setpoint Off: Power off or current less than 20% of range |
| Output Operation | Selectable: Normal or failsafe* |
| Time Delay | 0.5 to 16 sec. (adjustable) |
| Hysteresis | 5% |
| Isolation Voltage | UL listed to 2200 VAC |
| Frequency Range | 40-100 Hz |
| Case | UL94 V-0 Flammability Rated |
| Environmental | -4 to 122°F (-20 to 50°C) Surrounding Air 0-95% RH, non-condensing |
| Listings | UL/cUL, CE |

*For a description of failsafe operation, see the installation instructions.

Current Sensing Switch Ordering Information

Sample Model Number: AXSP8-SDT-120-MS
 AC current switch, 200-800 A range, SPDT relay output, 120 VAC powered, medium split-core case, DIN rail mounting.



(1) Range

| | |
|---|-----------|
| 2 | 50-200 A |
| 4 | 100-400 A |
| 6 | 150-600 A |
| 8 | 200-800 A |

(3) Output Type

| | |
|-----|---------------------------------|
| SDT | Single pole, double throw relay |
|-----|---------------------------------|

(4) Power Supply

| | |
|-----|------------|
| 24U | 24 VAC/VDC |
| 120 | 120 VAC |

(3) Case Style

| | |
|----|---|
| MS | Split-core, base terminals, DIN rail mounting |
|----|---|

Current Sensing Switches



ASXP-LS SERIES

Current Sensing Switches

ASXP-LS Series Current Switches combine a current transformer and signal conditioner into a single package. The large, easy-to-install, split-core design allows for installation over existing conductors without the need to disconnect the load, even in applications where there are multiple conductors per phase. For new installations, the installation is just as easy. Just remove the top portion of the sensing ring, place the conductors inside, and snap the top back in place. The switch output is externally powered, and the setpoint is adjustable between a very wide range. The mechanical relay contact provides a trouble free, long lasting, and very durable alarm or interlock, improving safety and overall system reliability.

Current Sensing Switch Applications

Monitor Large Machines

- Detect over or undercurrent conditions before they cause break downs, or interlock one process with another.

Water Delivery and Treatment

- Detect open discharge lines.
- Sense clogged filters or blocked intake to pumps.

Generators

- Shed noncritical loads when demand reaches a set level.

Interlock Infeed Conveyor with Main Crusher

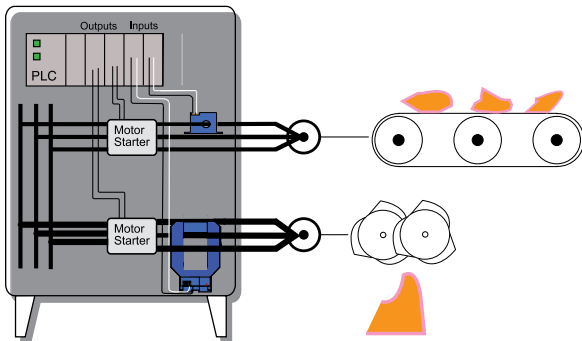

- For additional Application Examples, go to www.nktechnologies.com/applications



Current Sensing Switch Features

Electromechanical Relay Output

- Provides both normally open and normally closed contacts.
- Compatible with most automation and control systems.

Externally Powered

- Provides a choice of failsafe* or standard operation.

Simple Field Setpoint Adjustment

- Single turn potentiometer with setpoint shown on label.
- Adjustable start delay to bypass inrush current.

Split-core Case

- Sensing window provides ample space for bus bar, single or multiple conductors.

DIN Rail** or Panel Mounted Case

- Simple snap onto DIN rail or attach with screws to a panel for secure mounting.

UL/cUL and CE Approved

- Accepted worldwide.

*For a description of failsafe operation, see the installation instructions.

**For information on the DIN rail accessories kit, see page 147.

Current Sensing Switch Connections

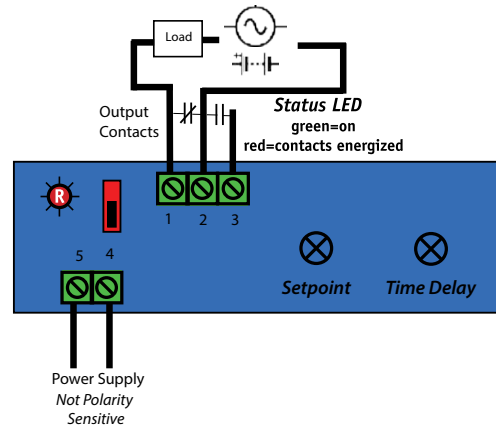

OEMs **Test & Evaluation Units for OEMs**
Free program expedites evaluation process. See page 3 for details.

Current Sensing Switch Dimensions

LS Case

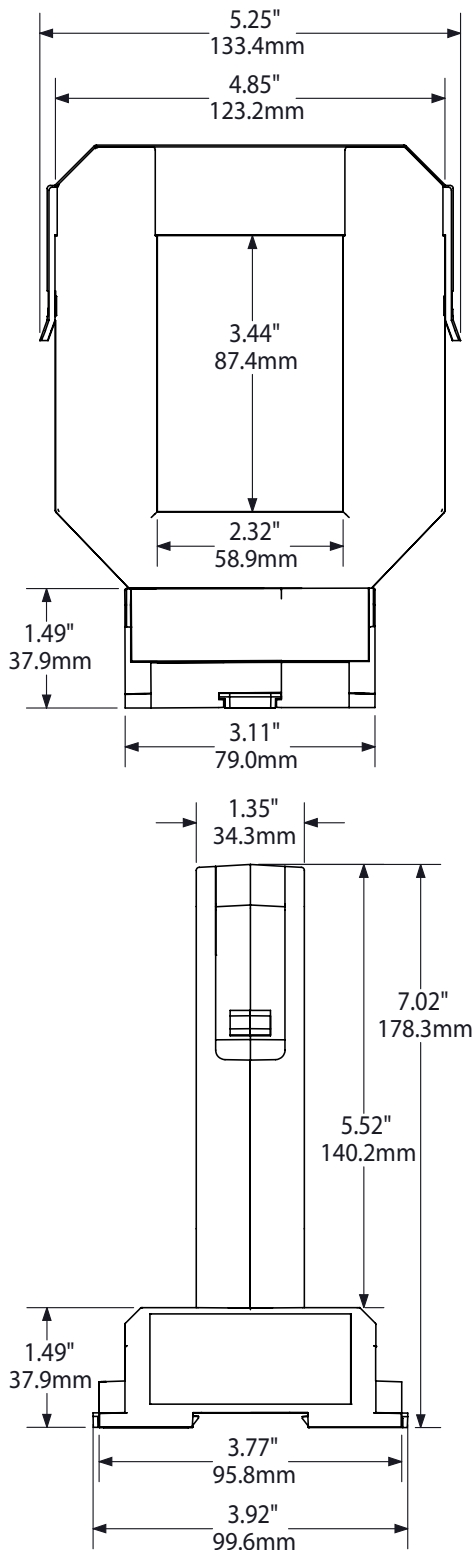

Current Sensing Switch Specifications



| | |
|--------------------------------|---|
| Power Supply | <ul style="list-style-type: none"> • 120 VAC (108–132 V) • 24 VAC/VDC (22–28 V) |
| Power Consumption | <4 VA |
| Input Range | <ul style="list-style-type: none"> • 8: 200–800 A • 10: 400–1000 A • 12: 600–1200 A • 16: 1000–1600 A |
| Output Switch | Electromechanical SPDT relay |
| Output Rating | 1 A @ 120 VAC, 2 A @ 30 VDC max. |
| Indicating Bi-color LED | Green: Power on, current within range Red: Power on, current over setpoint Off: Power off or current less than 20% of range |
| Output Operation | Selectable: Normal or failsafe* |
| Time Delay | 0.5 to 16 sec. (adjustable) |
| Hysteresis | 5% |
| Isolation Voltage | UL listed to 2200 VAC |
| Frequency Range | 40–100 Hz |
| Case | UL94 V-0 Flammability Rated |
| Environmental | -4 to 122°F (-20 to 50°C) Surrounding Air 0–95% RH, non-condensing |
| Listings | UL/cUL, CE |

*For a description of failsafe operation, see the installation instructions.

Current Sensing Switch Ordering Information

Sample Model Number: ASXP8-SDT-24U-LS

AC current sensing switch, 200–800 A range, single pole, double throw relay (Form C), 24 VAC/VDC, split-core case, DIN rail mounting.



(1) Range

| | |
|----|-------------|
| 8 | 200–800 A |
| 10 | 400–1000 A |
| 12 | 600–1200 A |
| 16 | 1000–1600 A |

(2) Output Type

| | |
|-----|---------------------|
| SDT | SPDT Relay (Form C) |
|-----|---------------------|

(3) Power Supply

| | |
|-----|------------|
| 24U | 24 VAC/VDC |
| 120 | 120 VAC |

(4) Case Style

| | |
|----|---|
| LS | Split-core, base terminals, DIN rail mounting |
|----|---|



DS1 SERIES

DC Current Sensing Switch

The DS1 Series Current Sensing Switch is designed to trip a solid-state contact when there is DC current through the sensor window. The sensor can be used to interlock two operations for safety. When one load is energized, the contact will keep another from also energizing. The power supply voltage and the controlled circuit voltage can be derived from a single source or separate sources. The monitored circuit can be any DC voltage and any amount of current as long as the conductor will pass through the window. The monitored circuit is completely isolated from the control circuit. If there is 3/4 of one amp through the aperture, the output will change state.



Current Sensing Switch Applications

- As a safety interlock, it is a non-intrusive method to keep personnel safe.
- Alarm contact when a load is operating or when it is not energized.
- Detect PV system earth leakage by monitoring the earth bond conductor.
- Use the contact to turn on a lighting circuit when a load is energized.
- Instant indication of equipment status.

Current Sensing Switch Features

Compact, One-piece Design

- Fits in easily amongst motor starters and power supplies in crowded control cabinets.

Input Isolation

- Safer than shunt/relay combinations.

Unique Power Supply Connection

- Sensor power and switched load share a common point making installation easy.

Built-in Mounting Feet

- Simple, two-screw installation allows for secure mounting, or attach to a DIN rail with the supplied adaptors*.

Designed for UL/cUL and CE Approval

- Accepted worldwide.

*For information on the DIN rail accessories kit, see page 147.

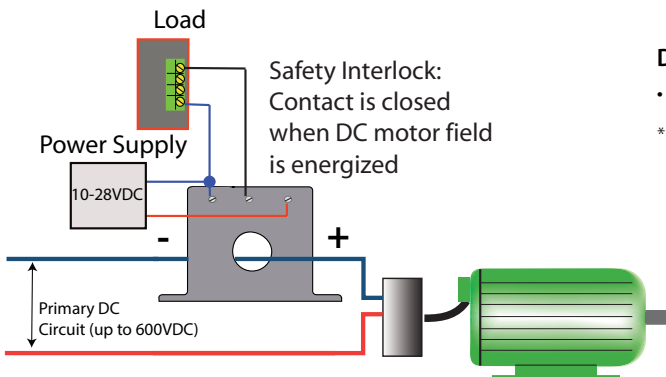

- For additional Application Examples, go to www.nktechnologies.com/applications

OEMs

Test & Evaluation Units for OEMs

Free program expedites evaluation process. See page 3 for details.

Current Sensing Switch Dimensions

FF Case

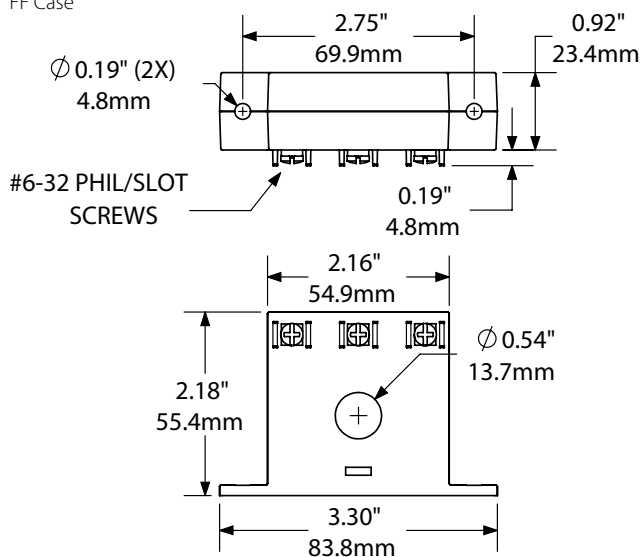

Current Sensing Switch Specifications

| | |
|--------------------------|---|
| Power Supply | 10–28 VDC (12 VDC nominal) |
| Power Consumption | <2 VA |
| Setpoint Range | 0.75 A (factory set) |
| Output Switch | Isolated solid-state switch |
| Off-state Leakage | <1 μ A |
| Response Time | 600 ms max. |
| Time Delay | None, after 5 seconds when first powered up |
| Output Rating | 1 A up to 30 VDC |
| Hysteresis | 5% |
| Overload | 500 A continuous, 1000 A @ 5 sec. |
| Isolation Voltage | Tested to 3 kV |
| Frequency Range | DC |
| Case | UL94 V-0 Flammability Rated |
| Environmental | -4 to 122°F (-20 to 50°C) 0–95% RH, non-condensing |
| Listings | Designed to meet UL/cUL and CE approval |

Current Sensing Switches

Current Sensing Switch Connections

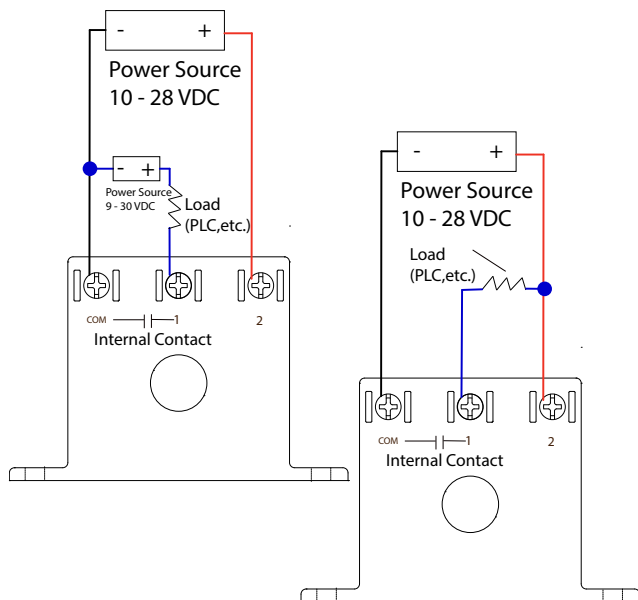

Notes:

Zinc plated screw terminals solid-core case.

Split core versions are not available.

14-22 AWG solid or stranded.

Current Sensing Switch Ordering Information

Sample Model Number: DS1-NODC-FF

Solid-core DC current sensing switch closes with 0.75 ADC, normally open, front terminal solid-core case. (DIN rail adapters are included)



(1) Range

| | |
|---|----------|
| 1 | 0.75 ADC |
|---|----------|

(2) Output Type

| | |
|------|------------------------------|
| NODC | Normally Open (1 A @ 28 VDC) |
|------|------------------------------|

(3) Case Style

| | |
|----|-----------------------------|
| FF | Solid-core, front terminals |
|----|-----------------------------|



DS3 SERIES

Current Sensing Switches

DS3 Series Current Sensing Switches combine a Hall effect sensor, signal conditioner and a limit alarm into a single package. The DS3 Series offers three jumper-selected current input ranges and frequency response from DC to 400 Hz. Available in a solid-core case with choice of relay or a universal solid-state output.

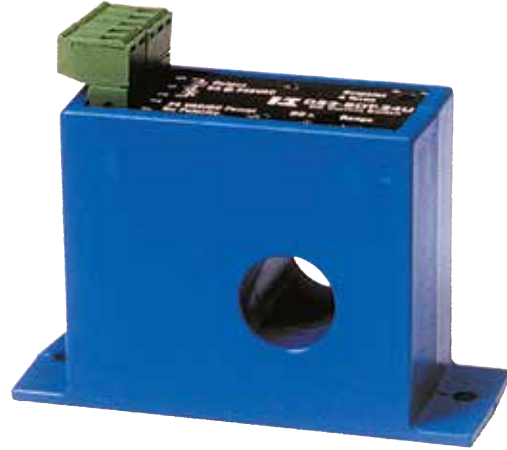

Current Sensing Switch Applications

Welders and Platers

- Instant indication of equipment status.

Large Drive Motors

- Provides enhanced field loss protection.

Power Supplies

- Signals overcurrent before equipment fails.

Machine Operation

- Instant status of motors, lamps and other loads.

Telecom Sites

- Monitors battery output.

Current Sensing Switch Features

Compact, One-piece Design

- Fits in easily amongst motor starters and power supplies in crowded control panels.

Input Isolation

- Safer than shunt/relay combinations.

Output Installation

- Isolated output greatly simplifies wiring.

Pluggable Terminals

- Speed installation.

Tough

- Designed to handle a wide range of temperatures found in industrial environments.

Adaptive Hysteresis

- Hysteresis is 5% of setpoint, allowing closer control than fixed hysteresis switches.

Built-in Mounting Feet

- Simple, two-screw installation allows for secure mounting.

UL/cUL and CE Approved

- Accepted worldwide.

Failure Detection

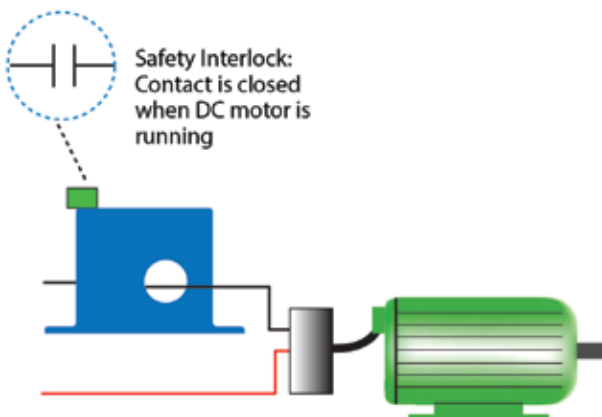

- For additional Application Examples, go to www.nktechnologies.com/applications

OEMs

Test & Evaluation Units for OEMs

Free program expedites evaluation process. See page 3 for details.

Current Sensing Switch Dimensions

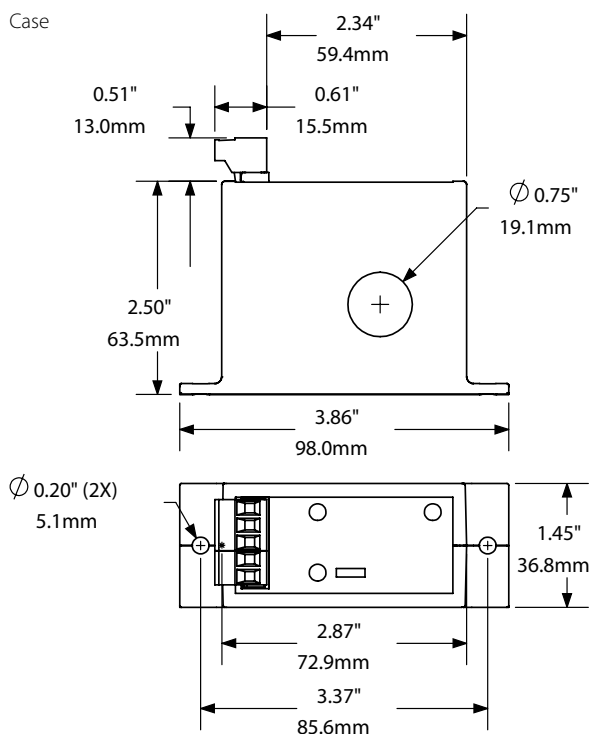

Current Sensing Switch Specifications



| | |
|--------------------------|--|
| Power Supply | 24U = 15-28 VAC/VDC 12U = 11.4-20 VAC/VDC |
| Power Consumption | <4 VA |
| Setpoint Range | 2-20, 10-50 and 20-100 A DC adjustable (2-14, 10-35, 20-70 A AC) |
| Output Switch | Isolated solid-state (NOU) or relay (SDT) contacts |
| Output Rating | • Solid-state: 0.15 A @ 240 VAC or VDC (N.O. only)* • Relay: 5.0 A @ 250 VAC, 5.0 A @ 30 VDC (SPDT only)* *General use |
| Off-state Leakage | <10 µA (solid-state), none (relay) |
| Response Time | 80 ms max. (On delay) 60 ms max. (Off delay) |
| Hysteresis | 5% of setpoint |
| Isolation Voltage | Tested to 1500 VAC |
| Frequency Range | DC to 400 Hz |
| Case | UL94 V-0 Flammability Rated |
| Environmental | -4 to 122°F (-20 to 50°C) 0-95% RH, non-condensing |
| Listings | UL/cUL, CE |

Current Sensing Switches

Current Sensing Switch Connections

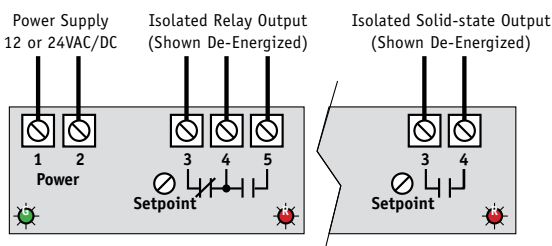

Notes:
Pressure plate screw terminals.
30-12 AWG solid or stranded.
Field-adjustable setpoint.

DS3 Series Sample Output/Power Supply

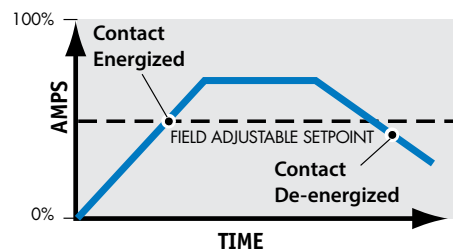

Current Sensing Switch Ordering Information

Sample Model Number: DS3-SDT-24U

DC current sensing switch with SPDT relay contacts and 24 VAC/DC power supply. (DIN rail adapters are included)



(1) Setpoint AC Range

| | |
|---|--|
| 3 | 2-20, 10-50 and 20-100 A, jumper-selectable (2-14, 10-35, 20-70 A AC) |
|---|--|

(2) Output Type

| | |
|-----|------------------------|
| SDT | SPDT Relay (Form C) |
| NOU | Solid-state N.O. AC/DC |

(3) Power Supply

| | |
|-----|------------|
| 24U | 24 VAC/VDC |
| 12U | 12 VAC/VDC |



DS1-FD SERIES

DC or AC Current Sensing Switches

DS1-FD Current Relays monitor AC or DC loads: motor, crane, or welding equipment. The relay features a large aperture and solid-core design that allows for quick installation, just thread the conductor through the sensing window (aperture) and reconnect on the other side. The relay output is isolated from the monitored circuit and can switch up to two amps up to 125 VAC, or two amps to 30 VDC. The output contacts can reset to original condition on current fall or latch in the tripped condition. The trip point (where the output relay changes state) can be adjusted between 20 and 400 amps by adjusting two potentiometers. One provides a “coarse” adjustment; the second allows for fine tuning of the trip point. The sensor mounts on a back panel or a DIN rail, and is designed to accommodate wire sizes for loads up to 400 amps or higher. The maximum current is unlimited, so current higher than the highest adjustment point will keep the relay in the tripped condition.



Current Relay Applications

Welding Processes

- Detect time of use using the normally open contact, which is closed with DC current over the trip point.

Under Current Detection

- If the power to the field of a shunt wound DC motor is lost, the speed will be uncontrollable. The normally closed contact will be open in normal operating conditions and closed to alarm if the field power is lost. Alternatively, the normally open contact could be closed during normal conditions and open the circuit to a contactor coil if the monitored circuit's current fell below the trip point.

DC Motors

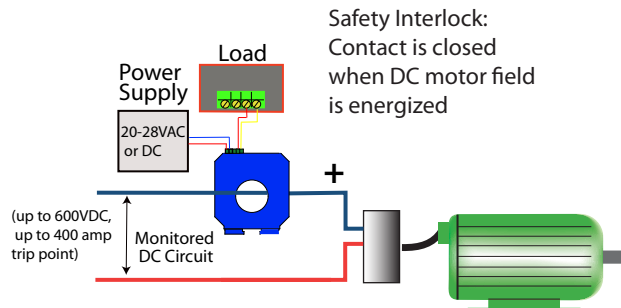

Current Relay Features

Factory Calibrated and Warranted For Five Years

- Trip point to 400 ADC or 338 AAC.
- Sensor is not polarity sensitive with regard to the monitored circuit.
- Designed for longest life and reliability.

Single Pole, Double Throw Relay Output

- Can control an AC or DC circuit.
- Compatible with most automation and control systems.
- Both NO contact for alarm (closing on current rise) and NC contact (opening on current rise) for disconnecting applications.
- Automatic reset or latching output available.
- Dual potentiometers allow for accurate trip point adjustment.

Externally Powered

- Simple and reliable connection.

Solid-core Case

- Sensing window provides ample space for single or multiple conductors.

DIN Rail or Panel Mount

- Simply snap onto a DIN rail* or attach with screws to a panel for secure mounting.

UL/cUL Approved

- Accepted worldwide.

*For information on the DIN rail accessories kit, see page 147.



Test & Evaluation Units for OEMs

Free program expedites evaluation process. See page 3 for details.

Current Relay Dimensions

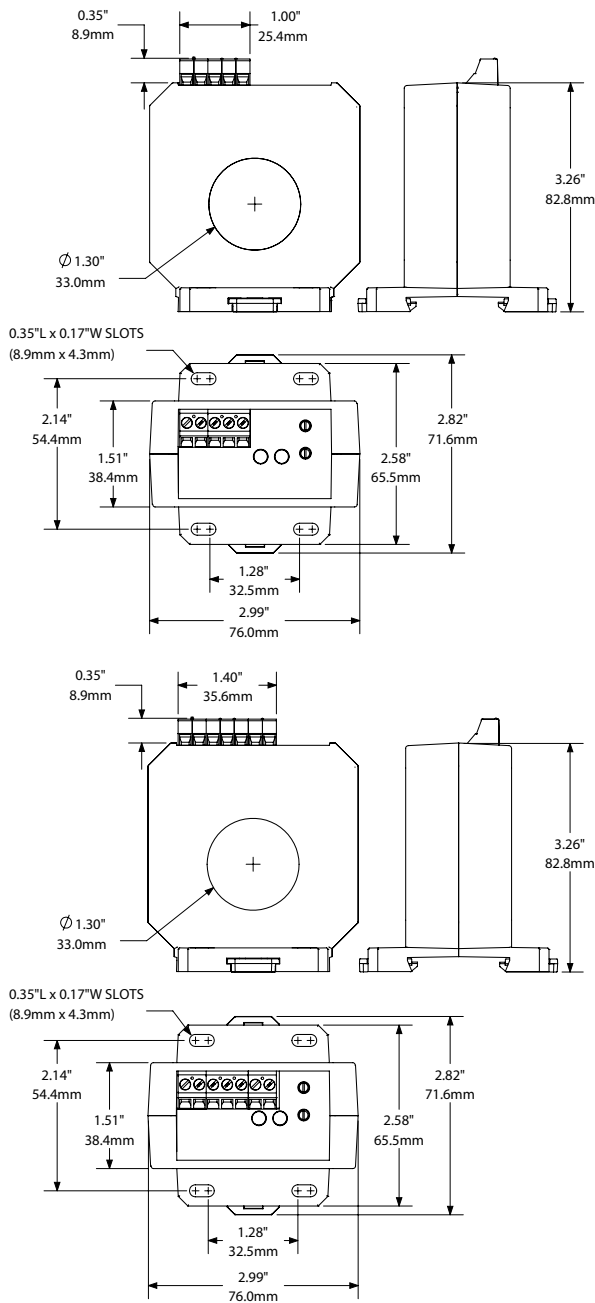

Current Relay Specifications

| | |
|--------------------------|---|
| Power Supply | 24U: 24 VAC/VDC (20–28 V) |
| Power Consumption | <2 VA |
| Output Switch | SPDT relay, 2 A @ 125 VAC, 2 A @ 30 VDC resistive |
| Overload | >1000 ADC (unlimited) |
| Response Time | 80 ms (max.) |
| Hysteresis | 5% |
| Setpoint Range | 20–400 ADC (17–338 AAC 60 Hz) |
| Isolation Voltage | UL listed to 1250 VAC |
| Frequency Range | DC to 400 Hertz |
| Environmental | -4 to 122°F (-20 to 50°C) 0–95% RH, non-condensing |
| Listings | UL/cUL |

Current Relay Ordering Information

Sample Model Number: DS1-SDTA-24U-FD
 DC current operated relay, 20–400 ADC adjustment range, SPDT relay output, 24 VAC/VDC powered, panel or DIN rail mounting.



(1) Range

| | |
|---|---|
| 1 | Adjustment range 20 to 400 ADC (17-338 AAC 60 Hz) |
|---|---|

(2) Output Auto Reset

| | |
|------|--|
| SDTA | Single Pole, double throw relay 2 A @ 125 VAC Auto Reset |
| SDTL | Single Pole, double throw relay 2 A @ 125 VAC Latching |

(3) Power Supply

| | |
|-----|----------------------------------|
| 24U | 24 VAC or VDC externally powered |
|-----|----------------------------------|

(4) Case Style

| | |
|----|-------------------------------------|
| FD | Solid-core, DIN rail or panel mount |
|----|-------------------------------------|

Current Relay Connections

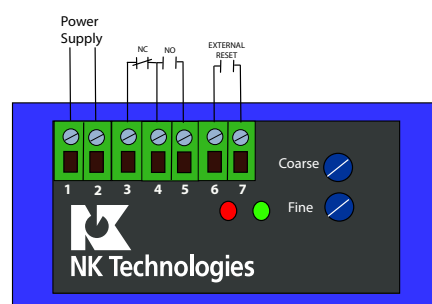

Latching

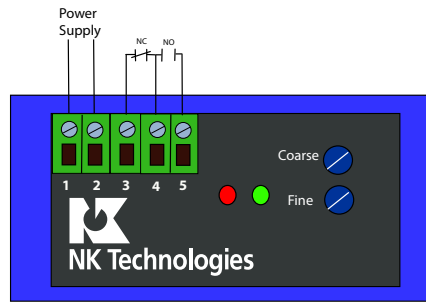

Auto Reset



AC Current Transducers

Current Transducers are designed to provide an analog signal proportional to the AC current for monitoring, data logging and panel meter applications. NK Technologies' current transducers offer a choice of 0–5 VDC, 0–10 VDC or 4–20 mA average responding or True RMS outputs. Self-powered and split-core options make these a cost-effective choice as a PLC input in motor status applications or where VFDs are involved.

Features:

- Average responding or True RMS output
- Jumper-selectable ranges
- Solid-core, split-core and large aperture models

| | |
|--|---------|
| ● AT SERIES AC Current Transducers..... | page 42 |
| ● ATR SERIES AC Current Transducers..... | page 44 |
| ● AT/ATR-TH SERIES AC Current Transducers..... | page 46 |
| ● AT/ATR-FD SERIES AC Current Transducers..... | page 48 |
| ● AT/ATR-FL SERIES AC Current Transducers..... | page 50 |
| ● AT/ATR-MS SERIES AC Current Transducers..... | page 52 |
| ● AT/ATR-LS SERIES AC Current Transducers..... | page 54 |
| ● ATCR SERIES AC Current Transducers..... | page 56 |
| ● ATP SERIES AC Current Transducers..... | page 58 |
| ● ATPR VOLTAGE OUTPUT SERIES AC Current Transducers..... | page 60 |
| ● ATP/ATPR-FL SERIES AC Current Transducers..... | page 62 |
| ● ATH SERIES AC Current Transducer with Time Integration..... | page 64 |
| ● ATQ SERIES Frequency Output AC Current Transducers..... | page 66 |
| ● ATS SERIES WITH DIGITAL SETPOINT DISPLAY AC Current Transducer/Switch..... | page 68 |
| ● ATS SERIES WITH ROTARY SWITCH SETPOINT AC Current Transducer/Switch..... | page 70 |

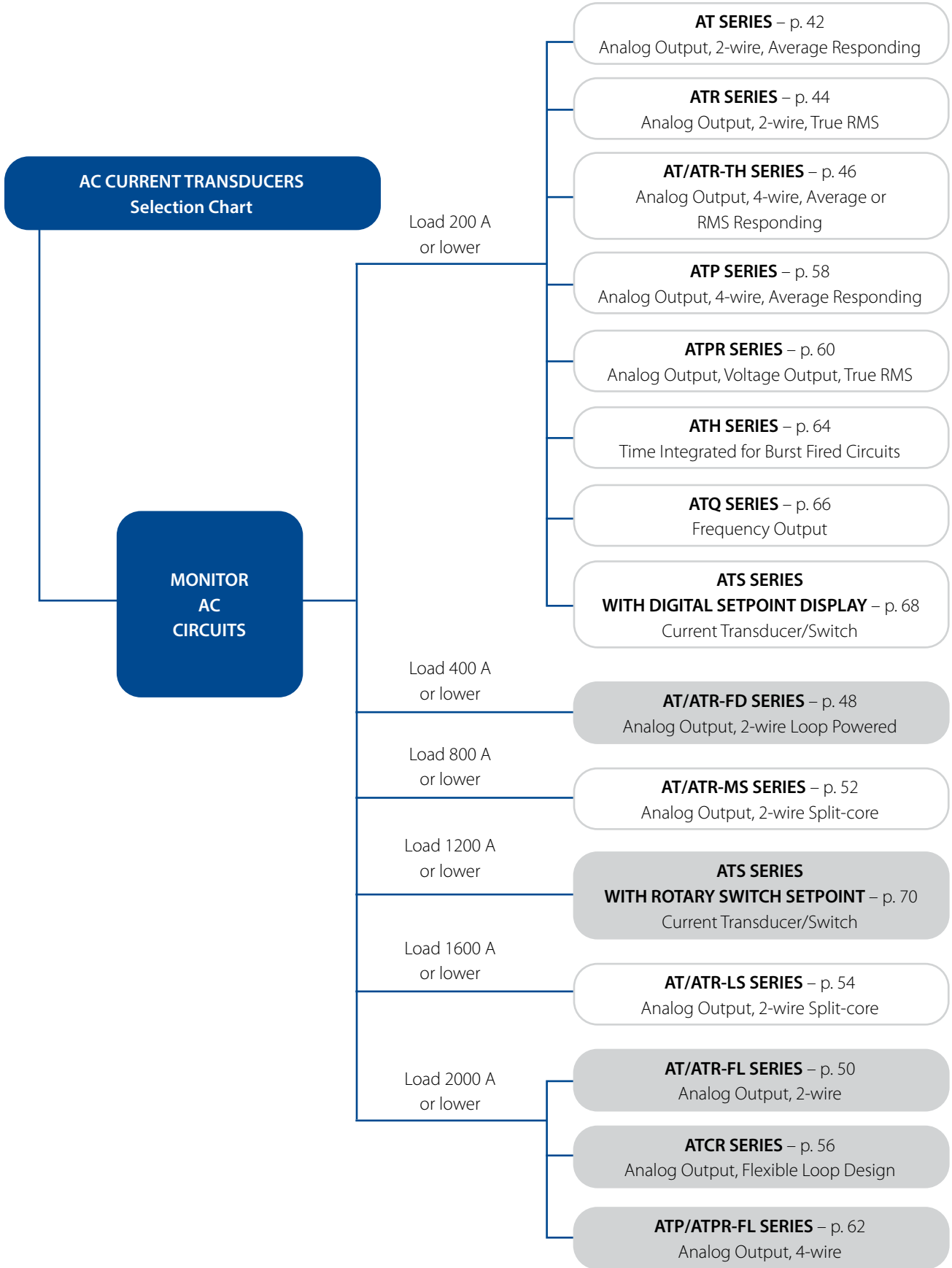

AT SERIES

AC Current Transducers

AT Series AC Current Transducers combine a current transformer and signal conditioner into a single package. These current transducers have jumper-selectable current input ranges and industry standard 4–20 mA, 0–5 VDC or 0–10 VDC outputs. The AT Series AC Current Transducers are designed for application on 'linear' or sinusoidal AC loads and are available in a split-core case or two types of solid-core cases.



AC Current Transducer Applications

Automation Systems

- Analog current reading for remote monitoring and software alarms.

Data Loggers

- Self-powered transducer helps conserve data logger batteries.

Panel Meters

- Simple connection displays power consumption.

Preventative Maintenance of a Critical Lighting System

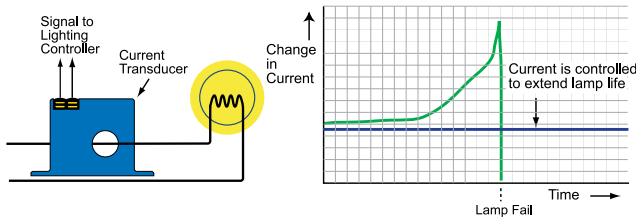

- For additional Application Examples, go to www.nktechnologies.com/applications

AT Series Power Supply

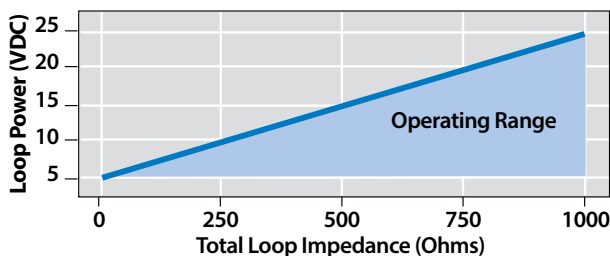

AC Current Transducer Features

Accurate

- Factory matched and calibrated single piece transducer is more accurate than traditional two-piece field installed solutions.

Average Responding

- "Average Responding" algorithm gives an RMS output on pure sine waves. Perfect for constant speed (linear) loads.

Jumper-selectable Ranges

- Reduces inventory.
- Eliminates zero and span pots.

Isolation

- Output is magnetically isolated from the input for safety.
- Eliminates insertion loss (voltage drop).

UL/cUL and CE Approved

- Accepted worldwide.

AC Current Transducer Connections

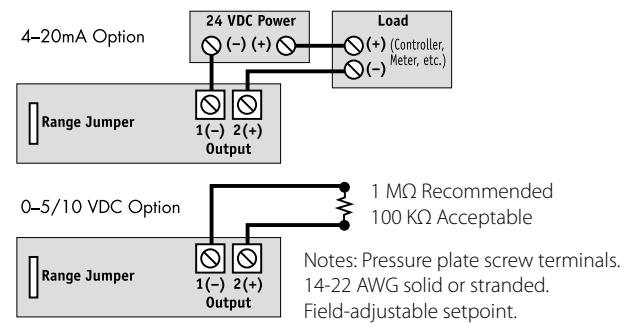

OEMs Test & Evaluation Units for OEMs
Free program expedites evaluation process. See page 3 for details.

AC Current Transducer Dimensions

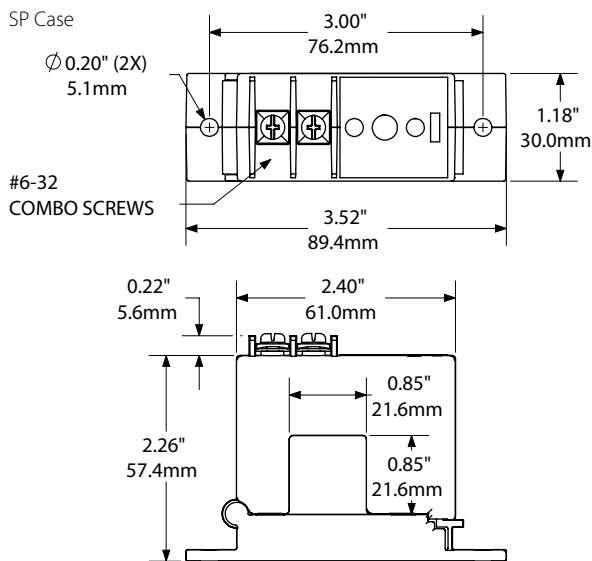
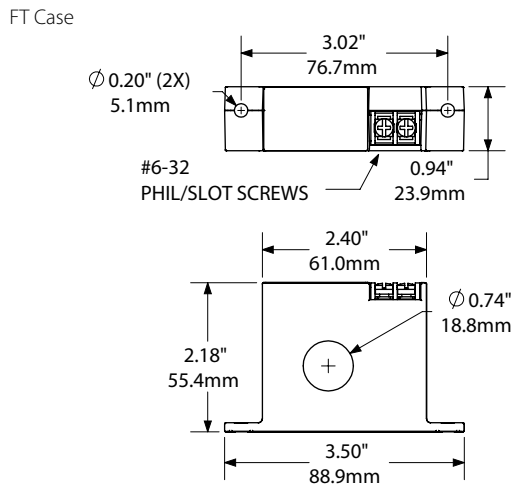
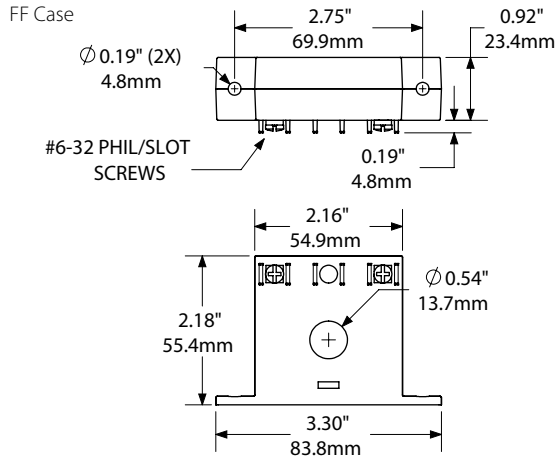

AC Current Transducer Specifications



| | -005 MODEL | -010 MODEL | -420 MODEL |
|--|---|------------|------------------------|
| Power Supply | None, self-powered | | 5–40 VDC, loop-powered |
| Output Signal | 0–5 VDC | 0–10 VDC | 4–20 mA |
| Output Limit | 8.2 VDC | 15 VDC | 32 mA |
| Output Loading | 1 MΩ min., 100 KΩ add 1.3% error | | |
| Accuracy | 1.0% FS | | |
| Response Time (90% step change) | 100 ms | | 300 ms |
| Frequency Range | 50–60 Hz | | 20–100 Hz* |
| Isolation Voltage | Tested to 1.5 KV | | |
| Input Range | 0–200 A field-selectable | | |
| Case | UL94 V-0 Flammability rated | | |
| Environmental | -4 to 122°F (-20 to 50°C) 0–95% RH, non-condensing | | |
| Listings | UL/cUL, CE | | |

*For sinusoidal waveforms only. Select ATR Transducers for distorted waveforms.

AC Current Transducers

AC Current Transducer Ordering Information

Sample Model Number: AT1-005-000-SP

AC current transducer, 10/20/50 A range, self-powered with a 0–5 VDC output in a split-core case. (DIN rail adapters are included)



(1) Full Scale Range

| | |
|---|---------------------------|
| 0 | 2 & 5 A (4–20 mA only) |
| 1 | 10, 20, 50 A |
| 2 | 100, 150, 200 A |

(2) Output Signal

| | |
|-----|----------|
| 420 | 4–20 mA |
| 005 | 0–5 VDC |
| 010 | 0–10 VDC |

(3) Power Supply

| | |
|-----|--|
| 24L | 24 VDC loop-powered (4–20 mA output only) |
| 000 | Self-powered (0–5/0–10 VDC output only) |

(4) Case Style

| | |
|----|----------------------------|
| FF | Solid-core, front terminal |
| FT | Solid-core, top terminal |
| SP | Split-core |



ATR SERIES

AC Current Transducers

ATR Series AC Current Transducers combine a current transformer and a True RMS signal conditioner into a single package. These current transducers provide True RMS output on distorted waveforms found on VFD or SCR outputs, and on linear loads in “noisy” power environments. The ATR Series AC Current Transducers are available in a solid- or split-core case.



AC Current Transducer Applications

VFD Controlled Loads

- Monitoring VFD output indicates how the motor and attached load are operating.

SCR Controlled Loads

- Accurate measurement of phase angle fired (time proportioned) SCRs.
- Current measurement gives faster response than temperature measurement.

Switching Power Supplies and Electronic Ballasts

- True RMS sensing is the most accurate way to measure power supply or ballast input power.

AC Current Transducer Features

True RMS Output

- True RMS technology is accurate on distorted waveforms like VFD or SCR outputs.

Jumper-selectable Ranges

- Reduces inventory.
- Eliminates zero and span pots.

Isolation

- Output is magnetically isolated from the input for safety.
- Eliminates insertion loss (voltage drop).

UL/cUL and CE Approved

- Accepted worldwide.

Monitoring a Motor Driven with a VFD

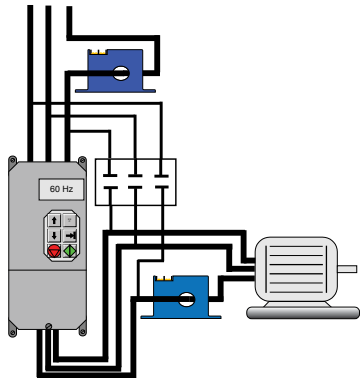

Use the ATR current transducer on the line or load side of the drive and the signal will be accurate in either position.

- For additional Application Examples, go to www.nktechnologies.com/applications

Selecting the right transducer:

The current waveforms of a typical linear load is a pure sine wave. In VFD and phase angle fired SCR applications, however, output waveforms are rough approximations of a sine wave. There are numerous spikes and dips in each cycle. ATR transducers use a mathematical algorithm called “True RMS” which integrates the actual waveforms over time. The output is the amperage component of the true power (heating value) of the AC current waveforms. True RMS is the only way to accurately measure distorted AC waveforms. **Select ATR transducers for nonlinear loads in “noisy” power environments.**

OEMs

Test & Evaluation Units for OEMs

Free program expedites evaluation process. See page 3 for details.

AC Current Transducer Dimensions

FT Case

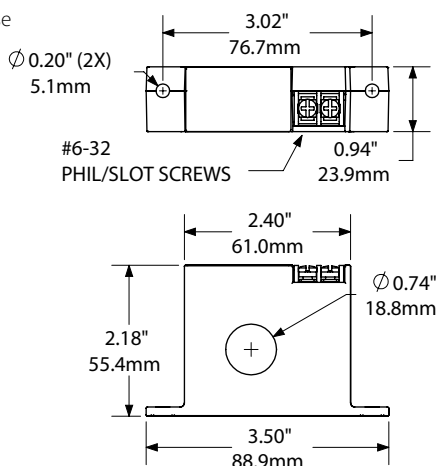

SP Case

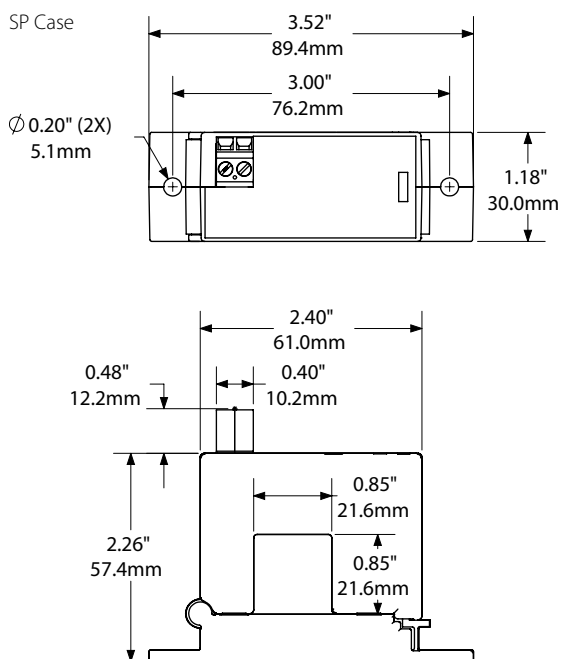

AC Current Transducer Connections

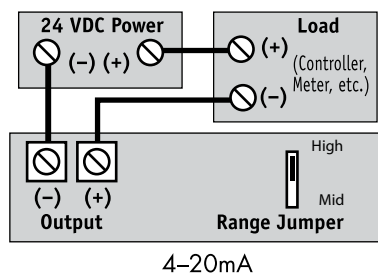

Notes:
 Deadfront captive screw terminals (-SP case).
 14-22 AWG solid or stranded.
 Observe polarity.

AC Current Transducer Specifications



| | |
|-------------------|---|
| Power Supply | 24 VDC (12-35 VDC) |
| Output Signal | 4-20 mA loop-powered, average or True RMS |
| Output Limit | 23 mA |
| Output Loading | <600 Ω @ 24 VDC |
| Accuracy | 1.0% FS |
| Response Time | 600 ms (to 90% step change) |
| Frequency Range | 10-400 Hz |
| Isolation Voltage | Tested to 1.5 KV |
| Input Range | 0-200 A (jumper selectable) |
| Case | UL94 V-0 Flammability Rated |
| Environmental | -4 to 122°F (-20 to 50°C) 0-95% RH, non-condensing |
| Listings | UL/cUL, CE |

AC Current Transducer Ordering Information

Sample Model Number: ATR1-420-24L-SP
 True RMS AC current transducer, 10/20/50 A ranges, 4-20 mA output, 24 VDC loop-powered in a split-core case. (DIN rail adapters are included)



(1) Full Scale Range

| | |
|---|-----------------|
| 0 | 2, 5 A |
| 1 | 10, 20, 50 A |
| 2 | 100, 150, 200 A |

(2) Output Signal

| | |
|-----|---------|
| 420 | 4-20 mA |
|-----|---------|

(3) Power Supply

| | |
|-----|---|
| 24L | 24 VDC loop-powered (4-20 mA output ONLY) |
|-----|---|

(4) Case Style

| | |
|----|---------------------------|
| FT | Solid-core, top terminals |
| SP | Split-core |

Power Supply Requirements

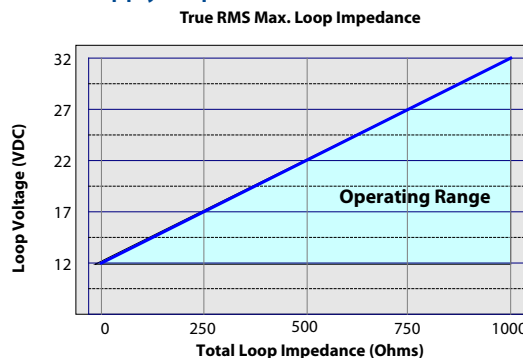

AT/ATR-TH SERIES

AC Current Transducers

AT/ATR-TH Series AC Current Transducers are the latest innovation for monitoring three-phase loads, motors, machines or buildings. The large triple-aperture solid-core design allows for a quick and easy installation. Just thread the conductors through the sensing windows (apertures) and reconnect on the other side. The transducer outputs are powered from an excitation voltage of 24 VAC or DC, or optionally 120 VAC, isolated from the monitored circuit. Three outputs are proportional to the AC current in each phase and a fourth represents the average of the three. Each are available at any time. The sensor mounts on a back panel or a DIN rail and is designed to accommodate wire sizes for loads up to 200 amps.



Current Transducer Applications

Monitor Large Machines

- Detect over or undercurrent conditions before they cause break downs or interlock one process with another.

Water Delivery and Treatment

- Detect open discharge lines.
- Sense clogged filters or blocked intake to pumps.
- Measure increased current to show failing bearings or pump impeller cavitation.

Generators

- Shed noncritical loads when demand reaches a set level.

Load Imbalance

- Monitor motor current draw which should be nearly equal in all three phases. A difference of 10% signifies trouble.

Submersible Pump Application

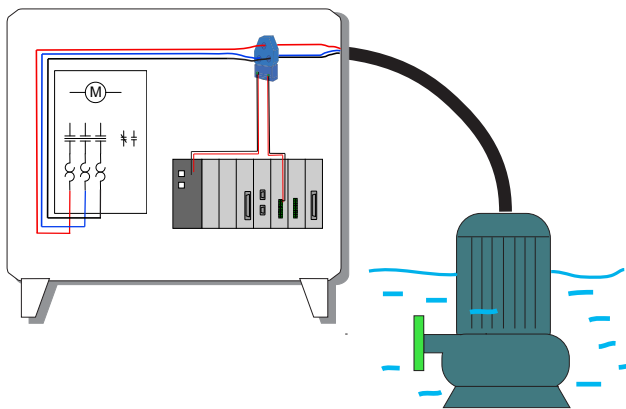

Current Transducer Features

Analog Signal Proportional to AC Current

- Both average responding and True RMS models available.
- Compatible with most automation and control systems.
- One output represents the current in each phase. A fourth produces a signal proportional to the average of the current in all three phases.

Externally Powered

- Simple and reliable connection.

Factory Calibrated and Warranted For Five Years

- Choice of ranges : 0–10 to 0–200 amps.
- Designed for longest life and reliability.

Solid-core Case

- Sensing windows provide ample space for single or multiple conductors per phase.

DIN Rail or Panel Mount

- Snap onto DIN rail or attach with screws to a panel for secure mounting.*

UL/cUL and CE Approved

- Accepted worldwide.

*For information on the DIN rail accessories kit, see page 147.



Test & Evaluation Units for OEMs

Free program expedites evaluation process. See page 3 for details.

Current Transducer Dimensions

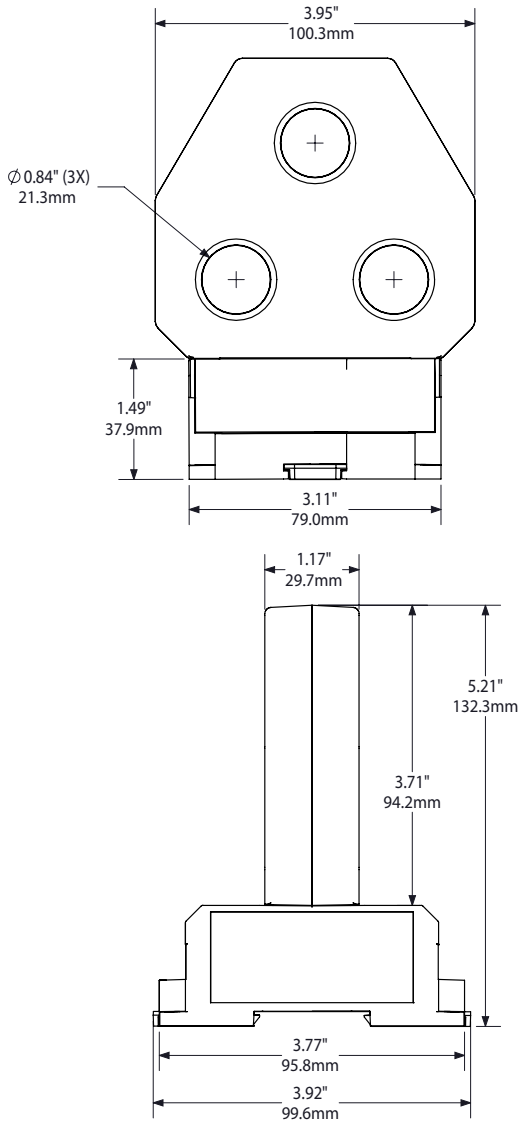

Current Transducer Connections

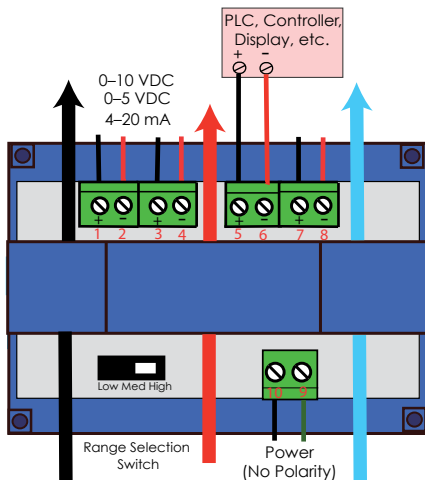

Current Transducer Specifications



| | | | | | | | |
|--------------------------|---|---|--|---|--|---|--|
| Power Supply | <ul style="list-style-type: none"> • 24 VAC/VDC (+/-10%) • 120 VAC (+/-10%) | | | | | | |
| Power Consumption | <6 VA | | | | | | |
| Output Signal | Three Individual analogs proportional to current in each phase, one analog proportional to the average of the three current levels. | | | | | | |
| Output Loading | <ul style="list-style-type: none"> • 4-20 mA: <500 Ω • 0-5/10 VDC >2K Ω | | | | | | |
| Response Time | 220 ms (90% step change) | | | | | | |
| Range | <table border="1"> <tr> <td>1</td> <td>0-10, 15 and 30 A (selectable by slide switch)</td> </tr> <tr> <td>2</td> <td>0-30, 50, 100 A (selectable by slide switch)</td> </tr> <tr> <td>3</td> <td>0-100, 150, 200 A (selectable by slide switch)</td> </tr> </table> | 1 | 0-10, 15 and 30 A (selectable by slide switch) | 2 | 0-30, 50, 100 A (selectable by slide switch) | 3 | 0-100, 150, 200 A (selectable by slide switch) |
| 1 | 0-10, 15 and 30 A (selectable by slide switch) | | | | | | |
| 2 | 0-30, 50, 100 A (selectable by slide switch) | | | | | | |
| 3 | 0-100, 150, 200 A (selectable by slide switch) | | | | | | |
| Isolation Voltage | UL listed to 1240 VAC | | | | | | |
| Frequency Range | 50-60 Hz. (Avg.), 30-100 Hz (RMS) | | | | | | |
| Case | UL94 V-0 Flammability Rated | | | | | | |
| Environmental | -4 to 122°F (-20 to 50°C) 0-95% RH, non-condensing | | | | | | |
| Listings | UL/cUL, CE | | | | | | |

AC Current Transducers

Ordering Information

Sample Model Number: ATR2-420-24U-TH, AC RMS current transducer, 0-100 A range, 4-20 mA output, 24 VAC/DC, 3 hole solid-core case, DIN rail mount.

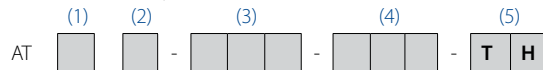

(1) Output Type

| | |
|---|----------------------------|
| | Average responding (blank) |
| R | True RMS |

(2) Range

| | |
|---|-------------------|
| 1 | 0-10, 15 and 30 A |
| 2 | 0-30, 50, 100 A |
| 3 | 0-100, 150, 200 A |

(3) Output Type

| | |
|-----|----------|
| 420 | 4-20 mA |
| 005 | 0-5 VDC |
| 010 | 0-10 VDC |

(4) Power Supply

| | |
|-----|------------------------------|
| 24U | 24 VAC/DC externally powered |
| 120 | 120 VAC externally powered |

(5) Case

| | |
|----|---|
| TH | Three-hole, solid-core, base terminals, DIN rail or panel mount |
|----|---|



AT/ATR-FD SERIES

AC Current Transducers

AT/ATR-FD Series AC Current Transducers provide a current sensor and analog output signal conditioning in a single package. The large, easy-to-install solid-core design allows for quick installation even in applications where there are multiple conductors per phase. Just thread the conductor through the extra large aperture and reconnect on the other side. The transducer output is powered from excitation voltage of around 24 VDC, using just two wires. The sensor mounts on a back panel or a DIN rail, and is designed to accommodate wire sizes for loads up to 400 A.



AC Current Transducer Applications

Monitor Large Machines

- Detect over or undercurrent conditions before they cause breakdowns or interlock one process with another.

Water Delivery and Treatment

- Detect open discharge lines.
- Sense clogged filters or blocked intake to pumps.
- Measure increased current to show failing bearings or pump impeller cavitation.

Generators

- Shed noncritical loads when demand reaches a set level.

Shredders

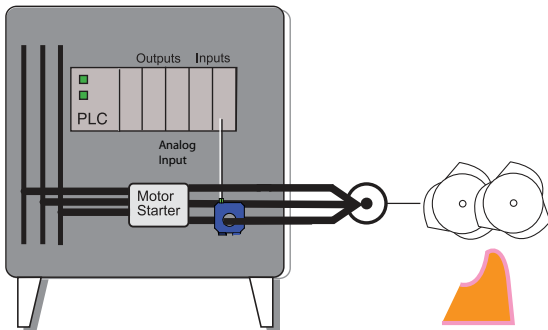

Monitor a shredding operation to measure current usage, enabling automatic shut down if the blades become jammed or overloaded.

- For additional Application Examples, go to www.nktechnologies.com/applications

OEMs

Test & Evaluation Units for OEMs

Free program expedites evaluation process. See page 3 for details.

AC Current Transducer Features

4–20 mA Analog Signal Proportional to AC Current

- Both average responding and True RMS models available.
- Compatible with most automation and control systems.

2-Wire Loop Powered

- Simple and reliable connection.

Factory Calibrated with Five Year Warranty

- Choice of three ranges : 0–200, 300 or 400 A.
- Designed for longest life and reliability.

Solid-core Case

- Sensing window provides ample space for a bus bar, a single conductor or multiple conductors.

DIN Rail or Panel Mount

- Simply snap onto DIN rail* or attach with screws to a panel for secure mounting.

UL/cUL and CE Approved

- Accepted worldwide.

*For information on the DIN rail accessories kit, see page 147.

AC Current Transducer Dimensions

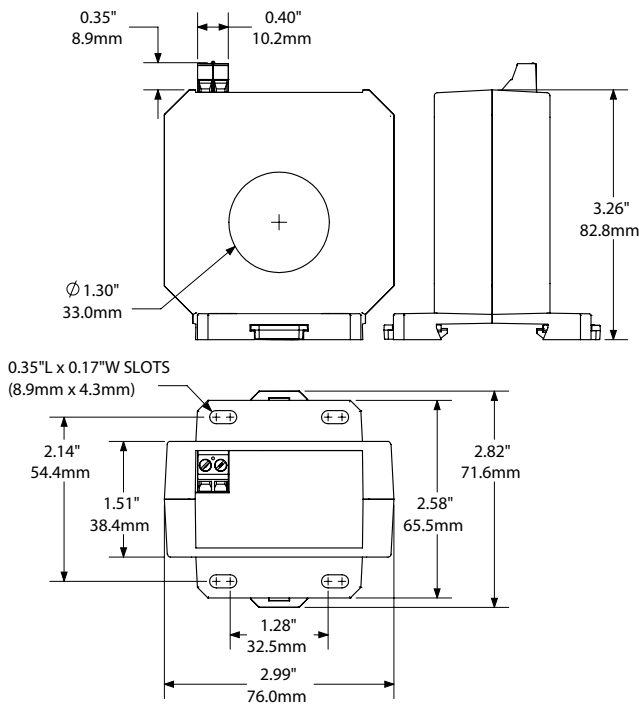

AC Current Transducer Connections

Single Transducer Installation

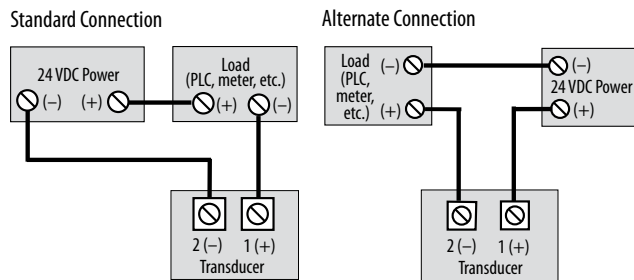

Loop Power Requirement

Maximum Loop Impedance

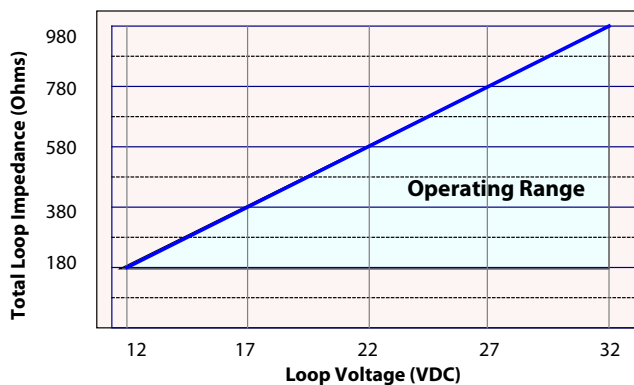

$$\text{Loop impedance (ohms)} = \frac{V (\text{supply voltage}) - 7.5 V}{0.025 A}$$

AC Current Transducer Specifications



| | |
|--|---|
| Power Supply | Loop-powered (24 VDC nominal) |
| Power Consumption | <2 VA |
| Output Signal | 4–20 mA loop-powered, average or True RMS (max. 28 mA) |
| Output Loading | <660 Ω @ 24 VDC |
| Accuracy | 1.0% FS |
| Response Time (90% step change) | • AT: 300 ms • ATR: 1.4 sec. |
| Input Range | • AT2/ATR2: 0–200 A • AT3/ATR3: 0–300 A • AT4/ATR4: 0–400 A |
| Frequency Range | • AT: 40–400 Hz • ATR: 20–400 Hz |
| Isolation Voltage | UL listed to 500 VAC |
| Environmental | -4 to 122°F (-20 to 50°C) 0–95% RH, non-condensing |
| Listings | UL/cUL, CE |

AC Current Transducers

AC Current Transducer Ordering Information

Sample Model Number: ATR2-420-24L-FD

AC True RMS current transducer, 0–200 A range, 4–20 mA output, 24 VDC loop-powered, solid-core case, DIN rail mounting.



| | |
|------------------|---|
| (1) Output Type | Average responding (Blank) |
| R | True RMS |
| (2) Range | |
| 2 | 0–200 A |
| 3 | 0–300 A |
| 4 | 0–400 A |
| (3) Output | |
| 420 | 4–20 mA |
| (4) Power Supply | |
| 24L | 24 VDC loop-powered |
| (5) Case Style | |
| FD | Solid-core, top terminals, DIN rail or panel mounting |



AT/ATR-FL SERIES

AC Current Transducers

AT/ATR-FL Series AC Current Transducers combine a current transformer and a signal conditioner into a single package for applications from 100 A to 2000 A. The AT version is Average Responding for use on linear (sinusoidal) loads. The ATR version is True RMS for use on distorted waveforms found in VFD or SCR outputs. The AT/ATR-FL Series AC Current Transducers are available in a solid-core case.

AC Current Transducer Applications

Large Pumps

- Detect dry run electronically.

Power Generation

- Measure the output of generators.

Electric Heating Elements

- Monitors heater loads.
- Faster response than temperature sensors.

Motor Load Monitoring

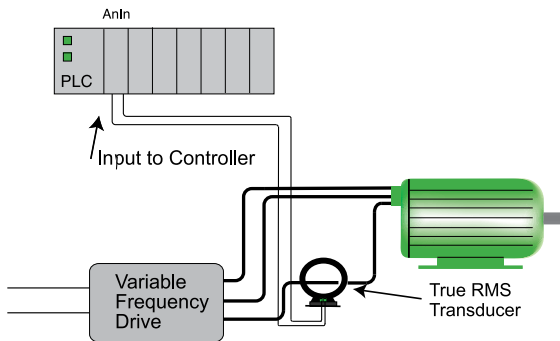

- For additional Application Examples, go to www.nktechnologies.com/applications

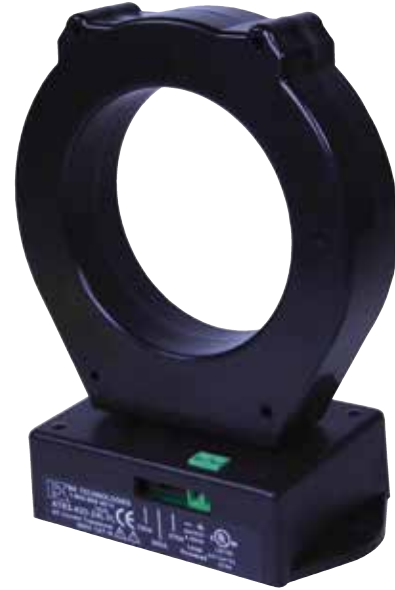

AC Current Transducer Features

Large Aperture

- Accommodates large conductors or wire bundles.

Select the Right Output

- True RMS technology is accurate on distorted waveforms like those associated with VFD or SCR outputs.
- Average Responding for use with linear, sinusoidal waveforms.

Jumper-selectable Ranges

- Reduces inventory.
- Eliminates zero and span pots.

Isolation

- Output is magnetically isolated from the input for safety.
- Eliminates insertion loss (voltage drop).

UL/cUL and CE Approved

- Accepted worldwide.

Selecting the right transducer:

The current waveforms of a typical linear load is a pure sine wave. AT transducers measure the peaks of these sine waves, then calculate the average amperage. This works well on constant speed linear loads in "clean" power environments. **Select AT transducers for strictly linear loads on "clean" power.**

VFD and SCR output waveforms are rough approximations of a sine wave. There are numerous spikes and dips in a mathematical algorithm called "True RMS," which integrates the actual waveforms over time. The output is the amperage component of the true power (heating value) of the AC current waveforms. True RMS is the only way to accurately measure distorted AC waveforms. **Select ATR transducers for nonlinear loads on "noisy" power.**



Test & Evaluation Units for OEMs

Free program expedites evaluation process. See page 3 for details.



AC Current Transducer Dimensions

FL Case

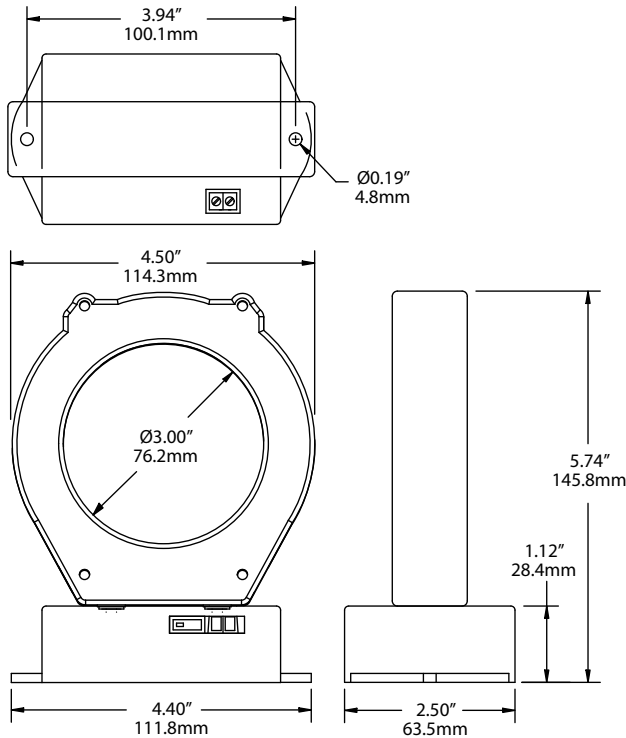

AC Current Transducer Connections

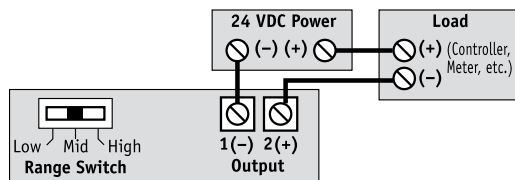

Notes:
 Deadfront captive screw terminals.
 14-22 AWG solid or stranded.
 Observe polarity.

AC Current Transducer Specifications



| | |
|--------------------------|---|
| Power Supply | 24 VDC normal, 40 VDC maximum |
| Output Signal | 4–20 mA loop-powered |
| Output Limit | 23 mA |
| Output Loading | 600 Ω @ 24 VDC |
| Accuracy | 1.0% FS |
| Measurement | True RMS or average responding (see ordering information) |
| Response Time | 500 ms (to 90% step change) |
| Frequency Range | • ATR: 10–400 Hz • AT: 50–60 Hz, sinusoidal |
| Isolation Voltage | Tested to 3 KV |
| Input Range | • AT/ATR2: 100, 133, 200 A • AT/ATR3: 375, 500, 750 A • AT/ATR4: 1000, 1333, 2000 A |
| Case | UL94 V-0 Flammability Rated |
| Environmental | -4 to 122°F (-20 to 50°C) 0–95% RH, non-condensing |
| Listings | UL/cUL, CE |

AC Current Transducers

AC Current Transducer Ordering Information

Sample Model Number: ATR3-420-24L-FL
 True RMS AC current transducer, 24 VDC, powered with a 4–20 mA output, 375/500/750 A ranges in a solid-core case.



| | | |
|----------------------|-----|----------------------------|
| (1) Measurement | R | True RMS |
| | | Average responding (blank) |
| (2) Full Scale Range | 2 | 100, 133, 200 A |
| | 3 | 375, 500, 750 A |
| | 4 | 1000, 1333, 2000 A |
| (3) Output Signal | 420 | 4–20 mA |
| (4) Power Supply | 24L | 24 VDC loop-powered |
| (5) Case Style | FL | Solid-core |



AT/ATR-MS SERIES

AC Current Transducers

AT/ATR-MS Series Current Transducers combine a current sensing element and signal conditioner into a single package. The large, easy-to-install split-core design allows for installation over existing conductors without the need to disconnect the load, even in applications where there are multiple conductors per phase. Whether installing over existing conductors or in a new control system, installation is very simple and quick. Just remove the top portion of the sensing ring, place the conductors inside, and snap the top back in place. The transducer uses two wires to connect to the power supply and the load (a programmable logic controller, a panel meter, or a data acquisition system).



AC Current Transducer Applications

Monitor Large Machines

- Measure the current use to detect over or undercurrent conditions before they cause break downs.

Water Delivery and Treatment

- Detect open discharge lines.
- Locate clogged filters or blocked intake to pumps.

Grinding and Shredding

- An analog output will allow the control system designer to allow brief periods of drive overload when the processed product varies in density. If the blades hit something foreign (e.g. steel when the machine is designed to reduce paper), then the control will alarm or shut down the process.

Shredder Monitoring

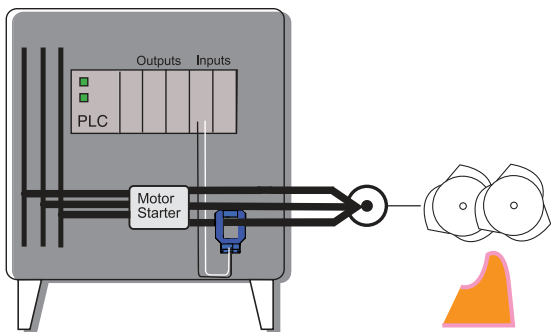

- For additional Application Examples, go to www.nktechnologies.com/applications

OEMs

Test & Evaluation Units for OEMs

Free program expedites evaluation process. See page 3 for details.

AC Current Transducer Features

Industry Standard Output

- 4–20 mA signal proportional to the AC current.
- Compatible with most automation systems.

Loop-powered

- Use the “live zero” output to verify proper connections, where the sensor output is 4 mA with no current through the sensing ring.

Factory Calibrated

- Eliminates zero and span potentiometer adjustment.

Split-core Case

- Sensing window provides ample space for bus bar, single or multiple conductors.

DIN Rail Mounted Case*

- Simply snaps onto DIN rail for secure mounting.

UL/cUL and CE Approved

- Accepted worldwide.

*For information on the DIN rail accessories kit, see page 147.

AC Current Transducer Connections

Single Transducer Installation

Standard Connection

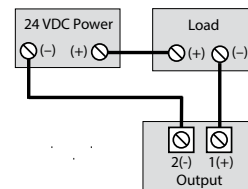

Alternate Connection

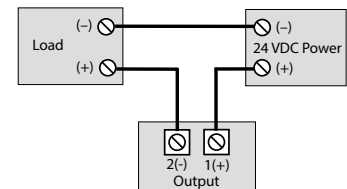

AC Current Transducer Dimensions

MS Case

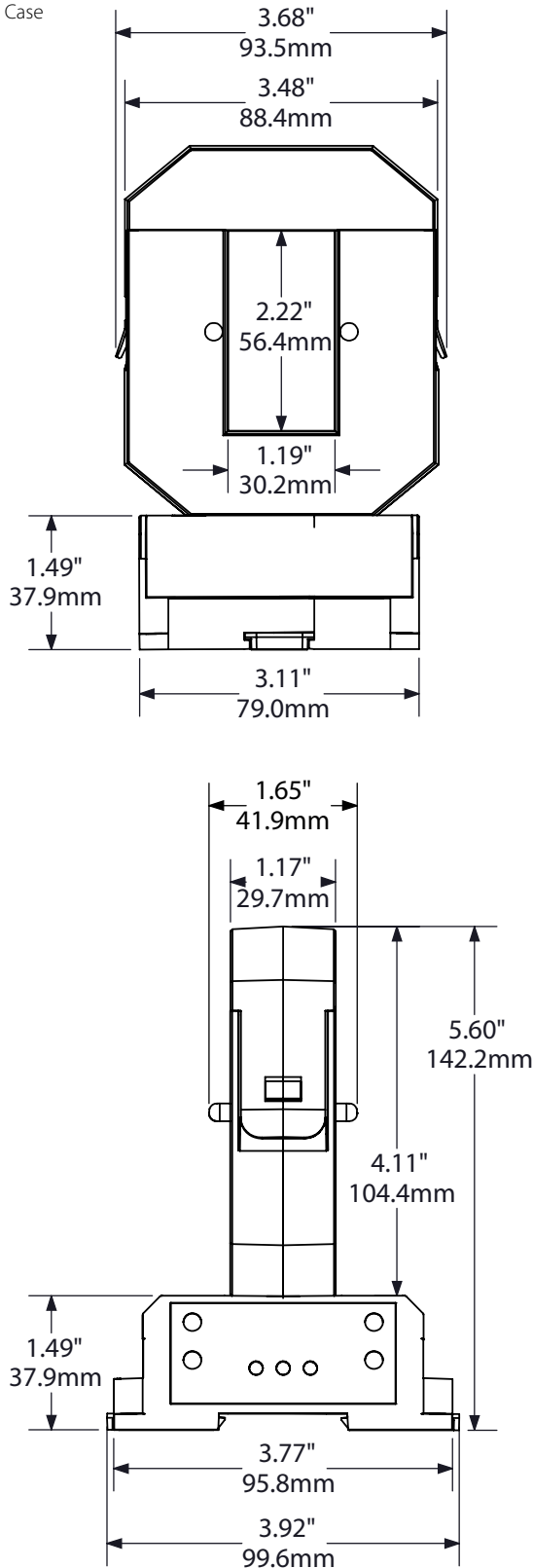

Note: Drawings are not to scale

AC Current Transducer Specifications



| | |
|--------------------------|---|
| Power Supply | 24 VDC nominal (12–32 VDC) |
| Output Signal | 4–20 mA loop-powered, average or True RMS |
| Output Limit | 23 mA |
| Output Loading | 660 Ω @ 24 VDC |
| Accuracy | 1.0% FS |
| Response Time | 600 ms (90% step change) |
| Input Range | 2: 0–200 A 3: 0–300 A 4: 0–400 A 6: 0–600 A 8: 0–800 A |
| Frequency Range | • AT: 50/60 Hz (average responding) • ATR: 20–400 Hz (True RMS responding) |
| Isolation Voltage | UL listed to 2200 VAC |
| Case | UL94 V-0 Flammability Rated |
| Environmental | -4 to 122°F (-20 to 50°C) 0–95% RH, non-condensing |
| Listings | UL/cUL, CE |

AC Current Transducers

AC Current Transducer Ordering Information

Sample Model Number: ATR6-420-24L-MS
AC current transducer, 0–600 A range, True RMS output 4–20 mA, loop-powered, medium split-core case, DIN rail mounting.



| | |
|------------------|--|
| (1) Measurement | |
| | Average responding output signal (blank) |
| R | True RMS responding output for distorted current |
| (2) Range | |
| 2 | 0–200 A |
| 3 | 0–300 A |
| 4 | 0–400 A |
| 6 | 0–600 A |
| 8 | 0–800 A |
| (3) Output Type | |
| 420 | 4–20 mA |
| (4) Power Supply | |
| 24L | 24 VDC Loop-powered |
| (5) Case Style | |
| MS | Split-core, base terminals, DIN rail mounting |



AT/ATR-LS SERIES

AC Current Transducers

AT/ATR-LS Series Current Transducers combine a current transformer and signal conditioner into a single package. The large, easy-to-install, split-core design allows for installation over existing conductors without the need to disconnect the monitored load, even in applications where there are multiple conductors per phase. For new installations, the process is just as easy. Just remove the top portion of the sensing ring, place the conductors inside, and snap the top back in place. The transducer uses two wires to connect to the power supply and the load (a programmable logic controller, a panel meter or a data acquisition system).



AC Current Transducer Applications

Monitor Large Machines

- Measure the current use to detect over or undercurrent conditions before they cause break downs.

Water Delivery and Treatment

- Detect open discharge lines.
- See clogged filters or blocked intake to pumps.

Generators

- Keep the power system running by monitoring the output.

Grinder/Shredder Application

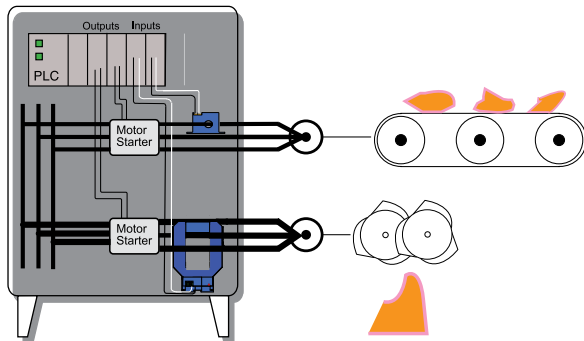

For additional Application Examples, go to www.nktechnologies.com/applications

AC Current Transducer Features

Industry Standard Output

- 4–20 mA signal proportional to the AC current.
- Compatible with most automation systems.

Loop-powered

- Use the “live zero” output to verify proper connections (4 mA sensor output with no current flowing confirms the system is ready to go).

Factory Calibrated

- Eliminates zero and span potentiometer adjustment.

Split-core Case

- Sensing window provides ample space for bus bar, single or multiple conductors.

DIN Rail Mounted Case*

- Simple snap onto DIN rail for secure mounting.

UL/cUL and CE Approved

- Accepted worldwide.

*For information on the DIN rail accessories kit, see page 147.

AC Current Transducer Connections

Single Transducer Installation

Standard Connection

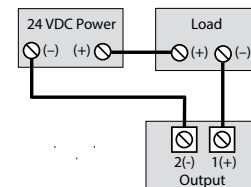

Alternate Connection

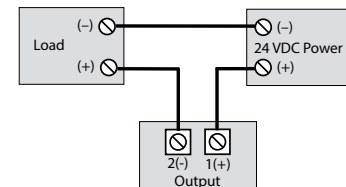

OEMs Test & Evaluation Units for OEMs
Free program expedites evaluation process. See page 3 for details.

AC Current Transducer Dimensions

LS Case

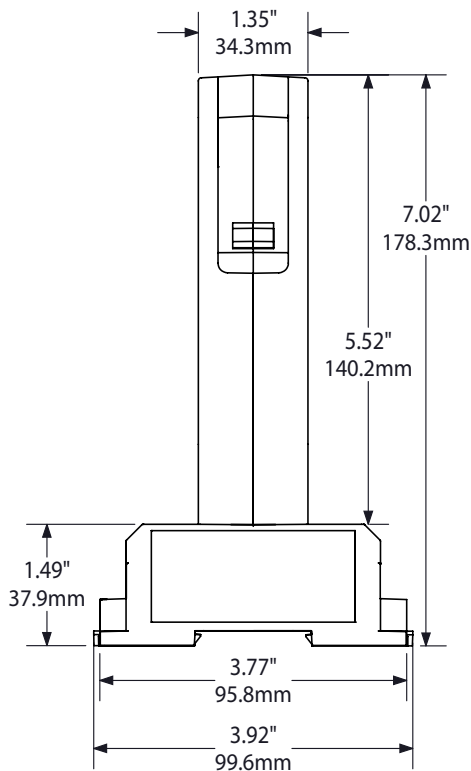
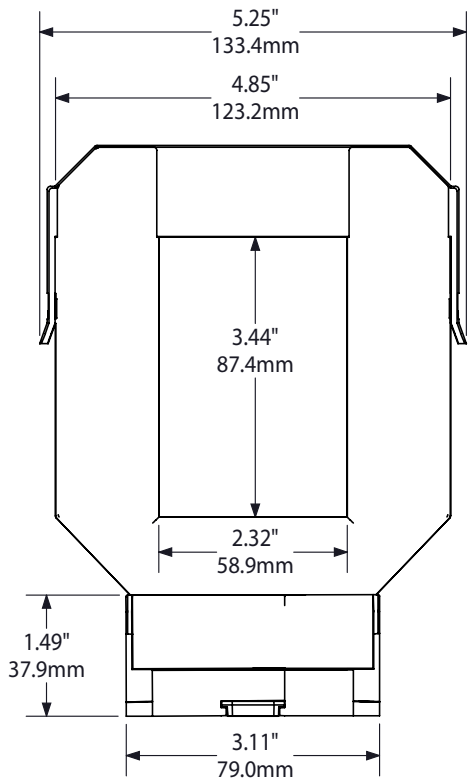

Note: Drawings are not to scale

AC Current Transducer Specifications



| | |
|--------------------------|---|
| Power Supply | 24 VDC nominal (12–32 VDC) |
| Output Signal | 4–20 mA loop-powered, average or True RMS |
| Output Limit | 23 mA |
| Output Loading | 660 Ω @ 24 VDC |
| Accuracy | 1.0% FS |
| Response Time | 600 ms (90% step change) |
| Input Range | 8: 0–800 A 10: 0–1000 A 12: 0–1200 A 16: 0–1600 A |
| Frequency Range | • AT: 50/60 Hz (average responding) • ATR: 20–400 Hz (True RMS responding) |
| Isolation Voltage | UL listed to 2200 VAC |
| Case | UL94 V-0 Flammability Rated |
| Environmental | -4 to 122°F (-20 to 50°C) 0–95% RH, non-condensing |
| Listings | UL/cUL, CE |

AC Current Transducers

AC Current Transducer Ordering Information

Sample Model Number: ATR10-420-24L-LS
 AC current transducer, 0–1000 A range, True RMS output 4–20 mA, loop-powered, large split-core case, DIN rail mounting.

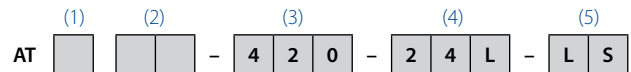

| | |
|------------------|--|
| (1) Measurement | |
| | Average responding (blank) |
| R | True RMS responding output for distorted current |
| (2) Range | |
| 8 | 0–800 A |
| 10 | 0–1000 A |
| 12 | 0–1200 A |
| 16 | 0–1600 A |
| (3) Output Type | |
| 420 | 4–20 mA |
| (4) Power Supply | |
| 24L | 24 VDC loop-powered |
| (5) Case Style | |
| LS | Split-core, base terminals, DIN rail mounting |



ATCR SERIES

AC Current Transducers

ATCR Series AC Current Transducers combine a sensing coil and a True RMS signal conditioner as a matched, factory-calibrated set. The ATCR Series AC Current Transducers are designed to produce an analog 4–20 mA signal proportional to AC current up to 2000 A. The coil opens to pass over the installed conductors. When connected to a controller or data logger, the sensor output is directly proportional to the primary current.



AC Current Transducer Applications

Monitor Large Machines

- Monitoring resistive or inductive load to detect current.
- Industry standard 4–20 mA output for connection to PLC or data loggers.

Flexible Coil Surrounds Conductors Without Disturbing Wiring

- Install over bus bars, or single or multiple conductors easily.
- Fast response to changes in operating conditions.

Two-Wire Loop-powered Output

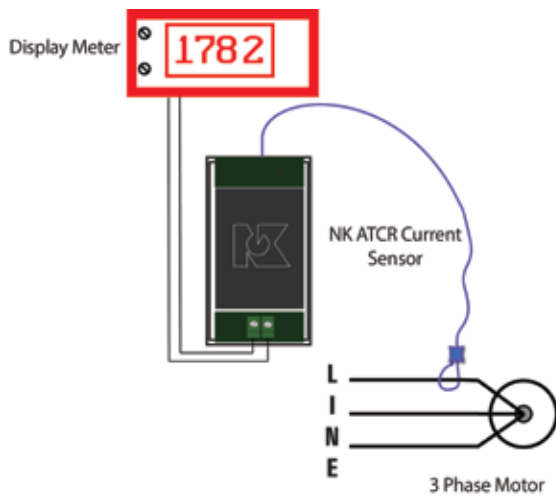

- For additional Application Examples, go to www.nktechnologies.com/applications

AC Current Transducer Features

True RMS Output

- True RMS technology is accurate on distorted waveforms like VFD or phase angle-fired SC outputs.

Single Range

- No chance of field range selection errors.
- Eliminates zero and span pots.

Isolation

- Output is magnetically isolated from the input for safety.
- Eliminates insertion loss (voltage drop).

Compact DIN Rail Mounted Case*

- Space saving 35 mm wide enclosure mounts quickly.

UL/cUL and CE Approved

- Accepted worldwide.

*For information on the DIN rail accessories kit, see page 147.

AC current monitoring of large loads:

Loads drawing large amounts of power are connected to the supply using large wire or a bus bar. Disconnecting the conductors and threading them through a solid sensing ring or current transformer is difficult and time consuming. With this new design, the sensing is accomplished using a coil without a magnetically permeable core. This allows the installer to pass the coil around the conductors after they are connected without the need to disconnect. The coil is attached to a signal conditioning circuit, and the output signal is powered from the 24 VDC nominal loop voltage. Simple, easy to install, the ATCR Current Sensor can monitor sinusoidal or distorted current waveforms at frequencies to 400 Hz, and is designed for industrial uses.

OEMs Test & Evaluation Units for OEMs
Free program expedites evaluation process. See page 3 for details.

AC Current Transducer Dimensions

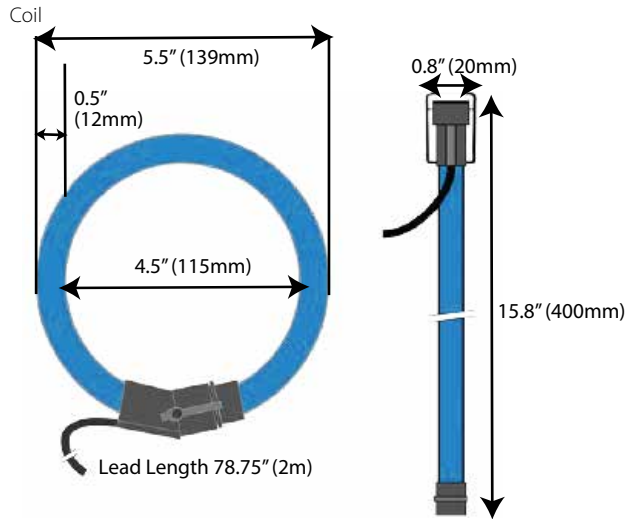
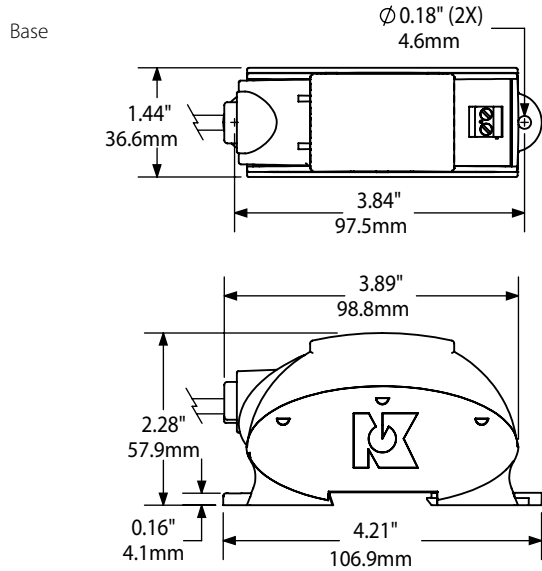

AC Current Transducer Connections

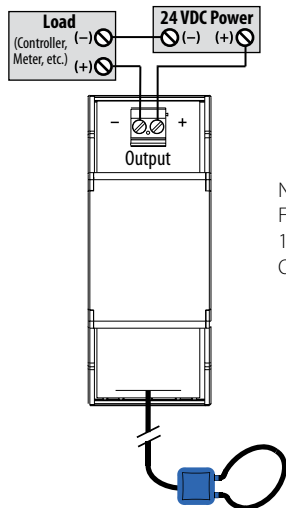

Notes:
 Fingersafe captive screw terminals.
 12-22 AWG solid or stranded.
 Observe polarity.

AC Current Transducer Specifications



| | |
|--------------------------|--|
| Power Supply | 24 VDC nominal (12–36 VDC) |
| Output Signal | 4–20 mA loop-powered, True RMS |
| Output Limit | 23 mA |
| Output Loading | <600 Ω @ 24 VDC |
| Accuracy | 1.0% FS from 10–100% of range |
| Response Time | 600 ms (90% step change) |
| Frequency Range | 40–400 Hz |
| Isolation Voltage | Tested to 3.5 KV |
| Input Range | Single range, custom ranges available; consult factory |
| Case | UL94 V-0 Flammability Rated |
| Environmental | -4 to 122°F (-20 to 50°C) 0–95% RH, non-condensing |
| Listings | UL/cUL, CE |

AC Current Transducer Ordering Information

Sample Model Number: ATCR1-420-24L-D
 True RMS AC current transducer, 500 A range, 4–20 mA output, 24 VDC loop-powered, coil sensor connected to DIN rail mounting case.

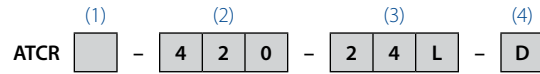

(1) Full Scale Range

| | |
|---|--------|
| 1 | 500 A |
| 2 | 1000 A |
| 3 | 1500 A |
| 4 | 2000 A |

(2) Output Signal

| | |
|-----|---------|
| 420 | 4–20 mA |
|-----|---------|

(3) Power Supply

| | |
|-----|---------------------|
| 24L | 24 VDC loop-powered |
|-----|---------------------|

(4) Case Style

| | |
|---|--|
| D | Coil connected to DIN rail mounting case |
|---|--|



ATP SERIES

AC Current Transducers

ATP Series AC Current Transducers sense currents from 0–200 A and provide a proportional analog VDC or mA output. Externally powered by 120 VAC/VDC or 24 VAC/VDC, the ATP Series AC Current Transducers eliminate the need for costly power supplies or voltage rectifiers inside the control panel. Designed for motor control applications with standard sinusoidal waveforms, these transducers feature user-selectable input ranges, a choice of outputs and split-core or solid-core cases.



AC Current Transducer Applications

Commercial and Industrial Motor Control Centers

- 120 VAC/VDC power supply option allows for powering off of readily available supplies; ideal for pumping, water/wastewater, boiler and other industrial applications.
- Eliminates the need for 24 VDC power supply or AC rectifiers within the control panel; saves space, material and labor associated with power supplies.

Heater Failure Detection

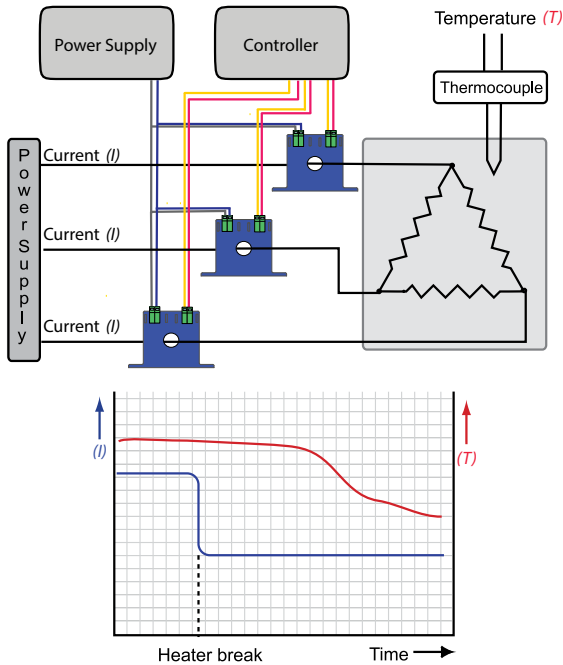

For additional Application Examples, go to www.nktechnologies.com/applications

OEMs

Test & Evaluation Units for OEMs

Free program expedites evaluation process. See page 3 for details.

AC Current Transducer Features

Fast, Accurate RMS Measurement

- Unique 'average responding' algorithm provides RMS output on pure sine wave and constant speed loads, offering improved accuracy over two-piece solutions.

Jumper-selectable Input Ranges

- Each unit has multiple input range capability and can be used for a variety of applications, reducing the need for separate models.

Isolation Output

- Output is magnetically isolated from the input for enhanced safety and elimination of insertion losses.

Designed for UL/cUL and CE Approval

- Accepted worldwide.

AC Current Transducer Connections

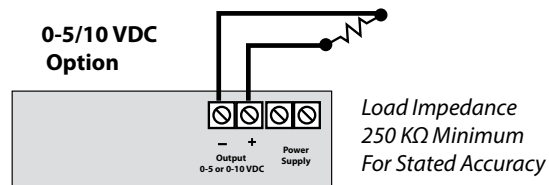
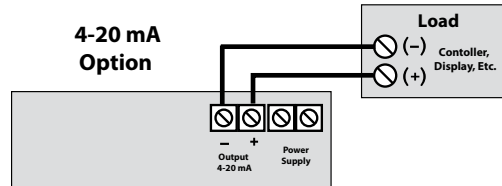

Notes:
Terminals are deadfront captive screw terminals.
Use 26-12 AWG solid or stranded.

AC Current Transducer Dimensions

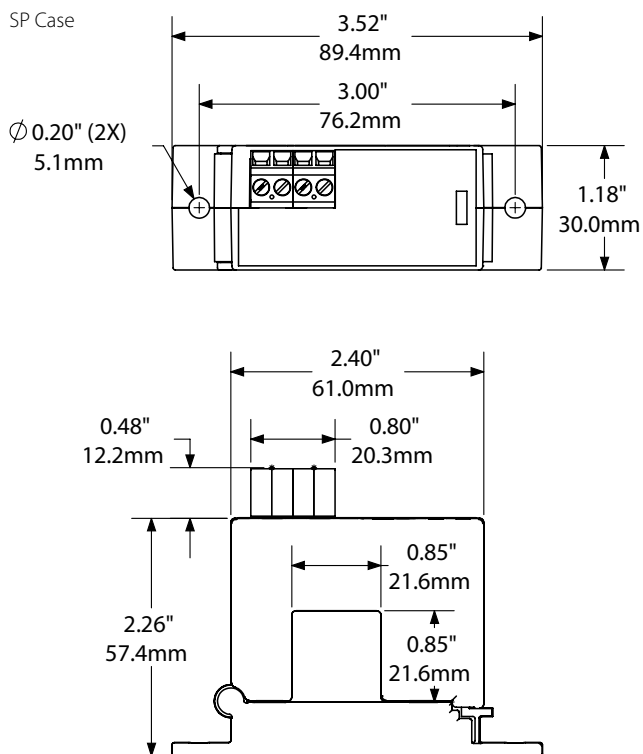
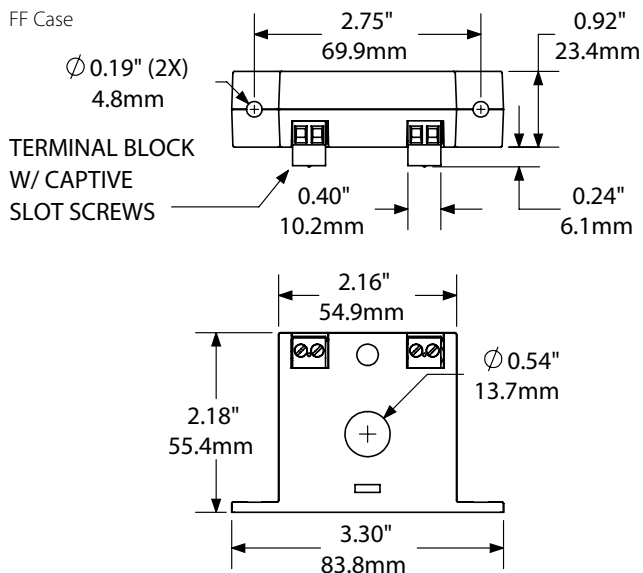

AC Current Transducer Specifications

| | |
|--------------------------|---|
| Power Supply | <ul style="list-style-type: none"> • 120 VAC/VDC (108–132 V) • 24 VAC/VDC (22–26 V) |
| Power Consumption | <2 VA |
| Output Signal | <ul style="list-style-type: none"> • -005 Model: 0–5 VDC • -010 Model: 0–10 VDC • -420 Model: 4–20 mA |
| Output Limit | <ul style="list-style-type: none"> • -005 Model: 112% (5.6 V) • -010 Model: 112% (11.2 V) • -420 Model: 112% (22.4 mA) |
| Output Loading | 250 KΩ min.: VDC models 500 Ω max.: 4–20 mA models |
| Accuracy | 1.0% FS |
| Response Time | 100 ms (10–90% step change) |
| Frequency Range | 40–100 Hz standard |
| Isolation Voltage | Tested to 1240 VAC |
| Input Range | 0–200 A jumper-selectable (see model list) |
| Environmental | -4 to 122°F (-20 to 50°C) 0–95% RH, non-condensing |
| Listings | Designed for UL/cUL and CE approval |

AC Current Transducers

AC Current Transducer Ordering Information

Sample Model Number: ATP1-420-120-SP
 Powered AC current transducer, jumper-selectable 0–10/20/50 A range, 4–20 mA output, 120 VAC/VDC power supply, split-core case. (DIN rail adapters are included)



(1) Full Scale Range

| | |
|---|-----------------|
| 0 | 2, 5 A |
| 1 | 10, 20, 50 A |
| 2 | 100, 150, 200 A |

(2) Output Signal

| | |
|-----|----------|
| 005 | 0–5 VDC |
| 010 | 0–10 VDC |
| 420 | 4–20 mA |

(3) Power Supply

| | |
|-----|---------------------------------|
| 120 | 120 VAC/VDC |
| 24U | 24 VAC/VDC with isolated output |

(4) Case Style

| | |
|----|------------|
| FF | Solid-core |
| SP | Split-core |



ATPR VOLTAGE OUTPUT SERIES

AC Current Transducers

ATPR AC Current Transducers combine a current transformer with a True RMS signal conditioner in a single package. These current transducers produce a 0–5 or 0–10 VDC True RMS output on distorted waveforms found in the output of variable frequency drives, phase angle fired heating controls and on linear loads in “noisy” power environments. The ATPR Series AC Current Transducers are available in split-core case only.



AC Current Transducer Applications

VFD Controlled Loads

- Monitor the output of variable frequency driven loads, even when the unit is in bypass mode.

SCR Controlled Loads

- Accurate measurement of phase angle fired heating controls.
- Current measurement produces a quicker response to element failure than temperature controls.

Switching Power Supplies and Electronic Ballasts

- True RMS sensing is the most accurate way to measure power supply and ballast input power.

Monitoring a Variable Frequency Drive

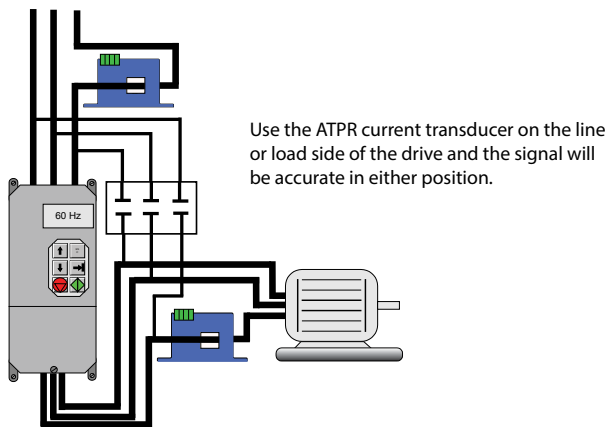

- For additional Application Examples, go to www.nktechnologies.com/applications

AC Current Transducer Features

True RMS Sensing

- Sensor output is proportional to the current flowing in the circuit, even with high distortion or harmonic loads.
- Compatible with most automation systems.

External Powered

- Provides the highest degree of accuracy and response.

Range-selectable

- One sensor covers a wide variety of loads.
- Field-selectable ranges keep spare part inventory at a minimum and allow for changes in load conditions.

Split-core Case

- Simple installation, release the latch and snap over the conductor.

DC Voltage Output

- Perfect for data acquisition systems, panel meters or controllers with only voltage inputs available.

Built-in Mounting Feet

- Simple, two-screw panel mounting or attach with DIN rail brackets (included).*

Designed for UL/cUL, CE Approval

- Accepted worldwide.

*For information on the DIN rail accessories kit, see page 147.

OEMs

Test & Evaluation Units for OEMs

Free program expedites evaluation process. See page 3 for details.

AC Current Transducer Dimensions

SP Case

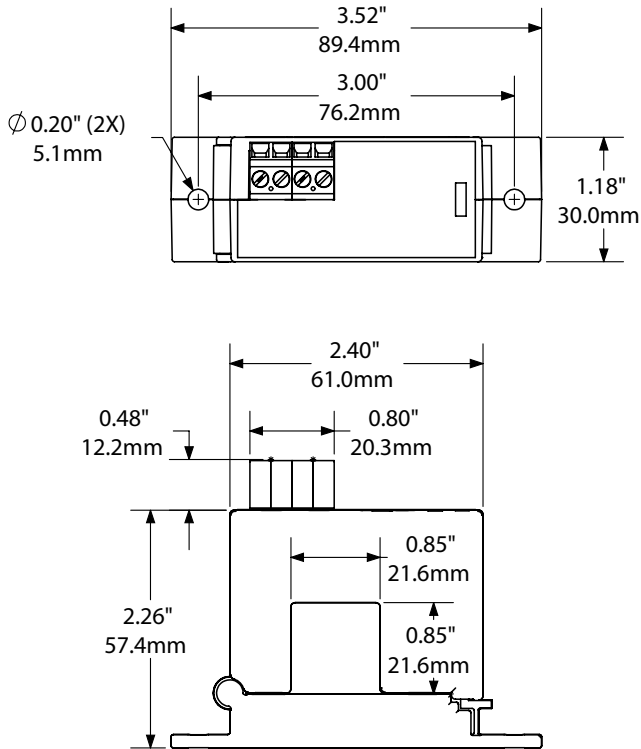

AC Current Transducer Connections

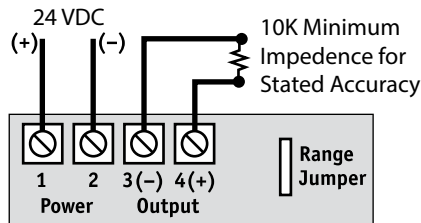

Observe Polarity. Power and Output are not Isolated.

AC Current Transducer Specifications

| | |
|-------------------|---|
| Power Supply | 24 VDC (20–28 VDC) |
| Power Consumption | <2 VA |
| Output Signal | • 0–5 VDC, proportional to True RMS current • 0–10 VDC, proportional to True RMS current |
| Output Loading | 10 KΩ min. |
| Accuracy | 1.0% FS |
| Response Time | 600 ms |
| Frequency Range | 40-100 Hz |
| Isolation Voltage | Tested to 3 KV |
| Case | UL94 V-0 Flammability Rated |
| Environmental | -4 to 122°F (-20 to 50°C) 0–95% RH, non-condensing |
| Listings | Designed for UL/cUL and CE approval |

AC Current Transducer Ordering Information

Sample Model Number: ATPR1-010-24D-SP
True RMS AC current transducer, 10/20/50 A FS input ranges, 0–10 VDC output, 24 VDC power supply, split-core case. (DIN rail adapters are included)



(1) Full Scale Range

| | |
|---|-----------------|
| 0 | 2, 5 A |
| 1 | 10, 20, 50 A |
| 2 | 100, 150, 200 A |

(2) Output Type

| | |
|-----|--------------------|
| 005 | 0–5 VDC, True RMS |
| 010 | 0–10 VDC, True RMS |

(3) Power Supply

| | |
|-----|--------|
| 24D | 24 VDC |
|-----|--------|

(4) Case Style

| | |
|----|------------|
| SP | Split-core |
|----|------------|



ATP/ATPR-FL SERIES

AC Current Transducers

ATP/ATPR-FL Series AC Current Transducers are large-format solid-core transducers designed for high current applications from 375 A to 2000 A. Powered by 120 VAC/VDC or 24 VAC/VDC, the ATP/ATPR-FL Series takes advantage of available power supplies and eliminates the need for costly control power transformers. Options include average responding and True RMS versions, 0–5/10 VDC or 4–20 mA analog outputs and switch-selectable input ranges.

AC Current Transducer Applications

Commercial and Industrial MCC's

- Fits conveniently in motor control centers, senses current on industrial motors and provides analog inputs back to PLC or controller.

VFD or SCR Controlled Loads, Electronic Ballasts

- Helpful in monitoring VFD-controlled motors to provide operational status. Provides accurate measurement of ballast input power and phase angle fired SCRs.

Large Pumping Applications

- Ideal for proof-of-flow in water/wastewater, boiler and other industrial pumping applications 150 HP and over. 120 VAC/VDC or 24 VAC/VDC supply options allow for powering off of readily available supply, eliminating need for CPTs.

Power Distribution Centers (PDCs)

- Monitors current output on commercial generation equipment and serves as a current input for use in power consumption calculations.



AC Current Transducer Features

Large Aperture

- Accommodates large conductors or wire bundles.

Select the Right Output

- True RMS technology is accurate on distorted waveforms like those associated with VFD or SCR outputs.
- Average responding for use with linear, sinusoidal waveforms.

Jumper-selectable Ranges

- Reduces inventory.
- Eliminates zero and span pots.

Isolation

- Output is magnetically isolated from the input for safety.
- Eliminates insertion loss (voltage drop).

Designed for UL/cUL, CE Approval

- Accepted worldwide.

Centrifugal Pump Monitoring

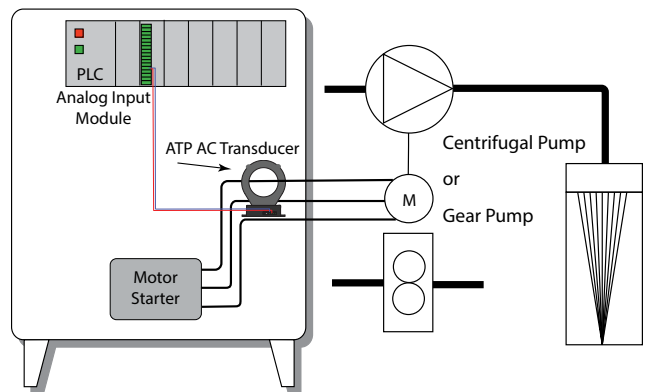

Test & Evaluation Units for OEMs

Free program expedites evaluation process. See page 3 for details.

- For additional Application Examples, go to www.nktechnologies.com/applications



AC Current Transducer Dimensions

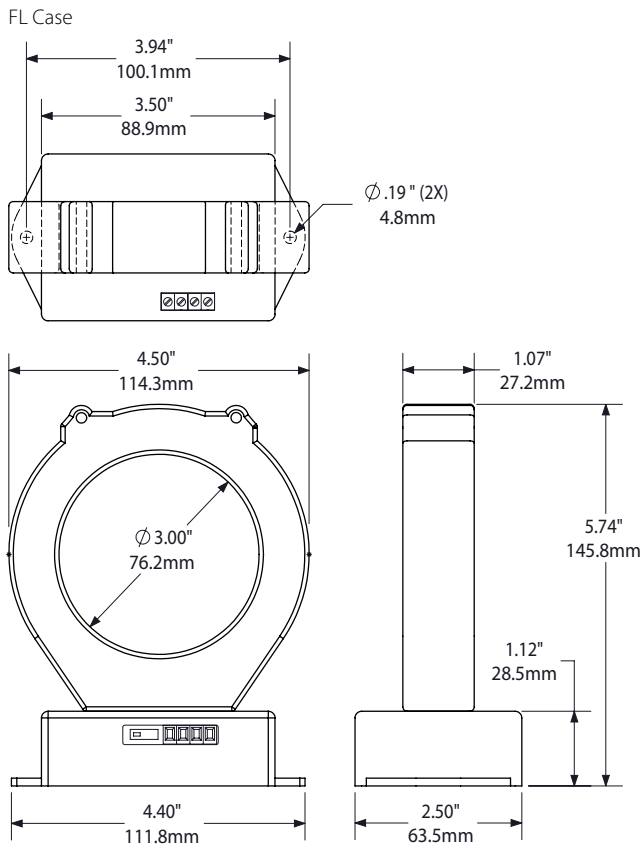

AC Current Transducer Connections

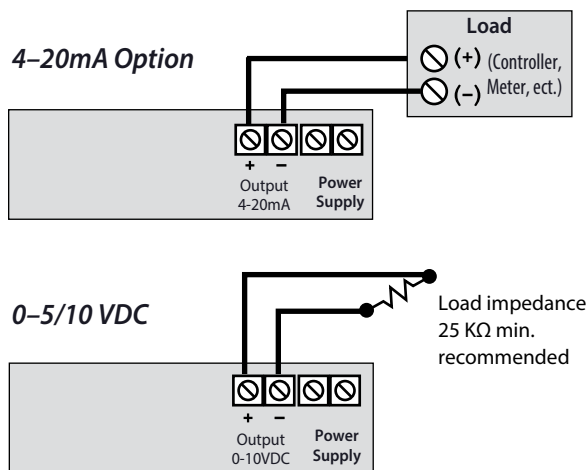

Notes:
Terminals are deadfront captive screw terminals.
Use 24-12 AWG solid or stranded.

AC Current Transducer Specifications

| | |
|--|---|
| Power Supply | • 120 VAC/VDC (108–132 V) • 24 VAC/VDC (22–26 V) |
| Power Consumption | <2 VA |
| Output Signal | • -005 Model: 0–5 VDC • -010 Model: 0–10 VDC • -420 Model: 4–20 mA |
| Output Limit | • -005 Model: 112% (5.6 V) • -010 Model: 112% (11.2 V) • -420 Model: 112% (22.4 mA) |
| Output Loading | 25 KΩ min.: VDC models 500 Ω max.: 4–20 mA models |
| Accuracy | 1.0% FS |
| Response Time | • ATP: 100 ms (10–90% step change) • ATPR: 600 ms (10–90% step change) |
| Frequency Range | • ATP: 40–100 Hz, sinusoidal • ATPR: 10–400 Hz |
| Isolation Voltage | Tested to 5 KV |
| Input Range (switch-selectable) | • ATP3/ATPR3: 0–375 A/500 A/750 A • ATP4/ATPR4: 0–1000 A/1333 A/2000 A |
| Case | UL94 V-0 Flammability Rated |
| Environmental | -4 to 122°F (-20 to 50°C) 0–95% RH, non-condensing |
| Listings | Designed for UL/cUL and CE approval |

AC Current Transducer Ordering Information

Sample Model Number: ATPR3-420-120-FL
True RMS AC current transducer, 120 VAC/VDC powered with a 4–20 mA output, 375/500/750 A ranges in a solid-core case.



| | |
|----------------------|----------------------------|
| (1) Measurement | |
| R | True RMS |
| | Average responding (blank) |
| (2) Full Scale Range | |
| 3 | 375, 500, 750 A |
| 4 | 1000, 1333, 2000 A |
| (3) Output Signal | |
| 005 | 0–5 VDC |
| 010 | 0–10 VDC |
| 420 | 4–20 mA |
| (4) Power Supply | |
| 24U | 24 VAC/VDC |
| 120 | 120 VAC/VDC |
| (5) Case Style | |
| FL | Solid-core |



ATH SERIES

AC Current Transducer with Time Integration

ATH Series (patented) AC Current Transducers are the latest innovation from NK Technologies. Monitoring the current or power controlled by silicon-controlled rectifiers (SCRs) can be a challenge, especially the current used by heaters. When used to monitor zero-crossing (burst) fired SCRs, the ATH will provide an output signal directly proportional to the RMS amperage. Zero-crossing fired controls allow current to flow to the circuit for as short of a time period as one cycle, and off for several cycles. Most current sensors will not work well when there is no current present. This capability is important in case a heating element fails but the process continues operating, which could result in scrapped material.

AC Current Transducer Applications

Electrical Heaters

- Faster response than temperature sensors.
- Simplest method to monitor pulsed waveforms.

Burst-Fired Heating Controls

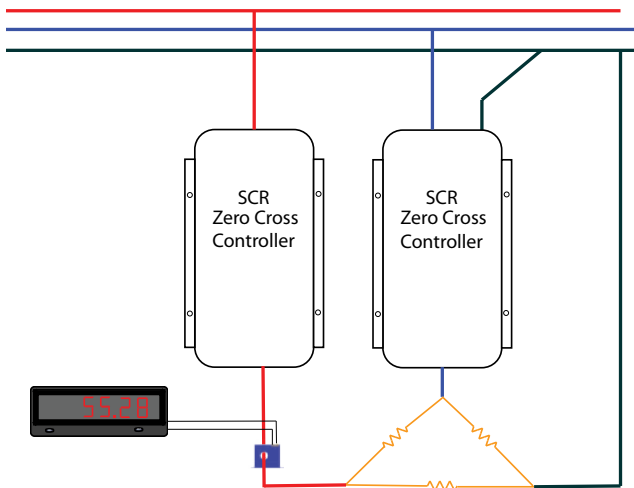

- For additional Application Examples, go to www.nktechnologies.com/applications

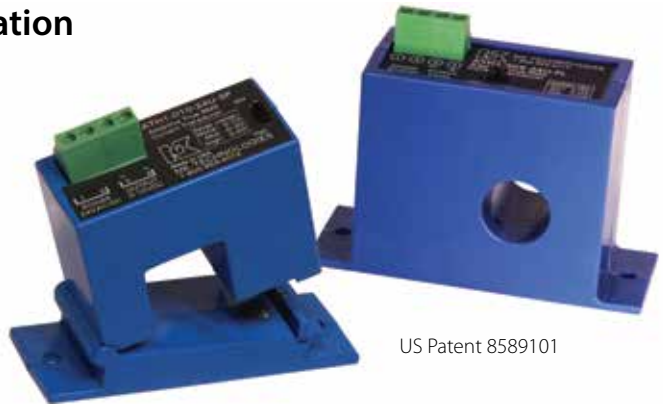

US Patent 8589101

AC Current Transducer Features

Industry Standard Outputs

- 4–20 mA, 0–5 or 0–10 VDC.
- Compatible with most automation systems.

External Powered

- Split-core models powered with 24 VAC or DC.
- Solid-core models powered with 24 VAC or DC or 120 VAC.

Factory Calibrated

- No need for zero and span adjustment potentiometers.

RMS Output

- Accurate measurement of sinusoidal or pulsed current wave shapes.

Built-in Mounting Feet

- Simple, two-screw panel mounting or attach with DIN rail brackets (included).*

UL/cUL and CE Approved

- Accepted worldwide.

*For information on the DIN rail accessories kit, see page 147.

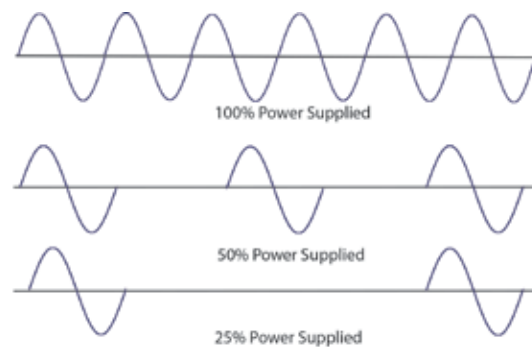

ATH AC current transducers will produce a signal proportional to the current used even when the controller is supplying power in one cycle increments. This is quite common as the "burst-fired" zero crossing switching method produces less harmonic distortion than phase-angle fired controls.

OEMs Test & Evaluation Units for OEMs
Free program expedites evaluation process. See page 3 for details.

AC Current Transducer Dimensions

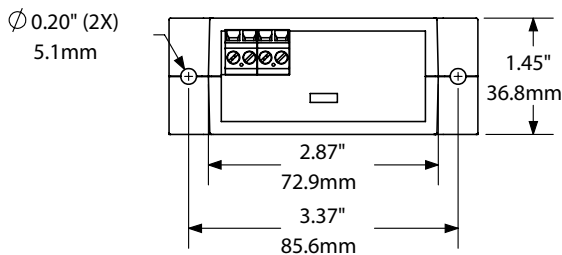
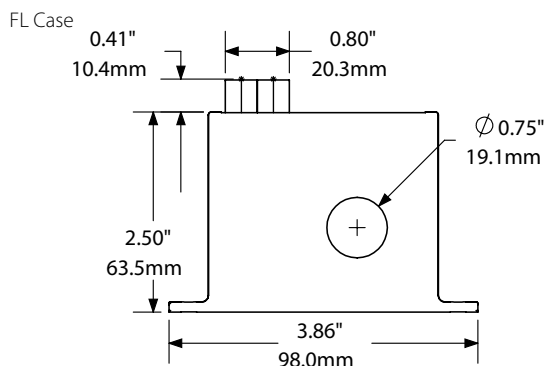
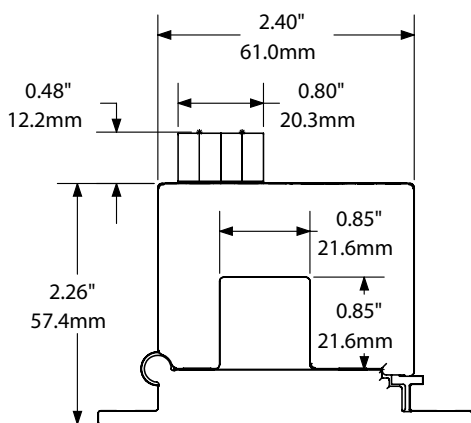
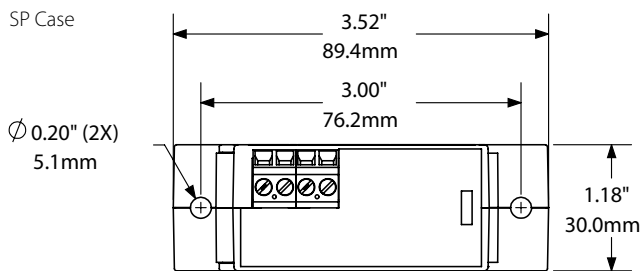

AC Current Transducer Connections

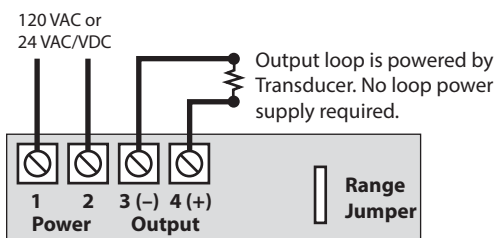

AC Current Transducer Specifications



| | |
|--------------------------|--|
| Power Supply | • 120 VAC (+/-10%) solid-core only • 24 VAC/VDC (+/-10%) solid or split-core |
| Power Consumption | <2 VA |
| Output Signal | • 4–20 mA (20 mA maximum) • 0–5 VDC (5 VDC maximum) • 0–10 VDC (10 VDC maximum) |
| Output Loading | • 0–5 or 0–10 VDC: 10 KΩ min. • 4–20 mA: 500 Ω max. |
| Accuracy | 1% FS |
| Response Time | • <30 ms + duty-period (FL) for 90% step change • <40 ms + duty-period (SP) for 90% step change • <50 ms + duty-period for 100% step change • <400 ms for 100% duty cycle • PWM Cycle Period: 12 ms (min.), 54 sec (max.) • 79 sec for timeout to default period • 206 ms for default period when absence of signal for 79 sec |
| Frequency Range | 40–400 Hz |
| Isolation Voltage | Tested to 1240 VAC |
| Case | UL94 V-0 Flammability Rated |
| Environmental | -4 to 122°F (-20 to 50°C) 0–95% RH, non-condensing |
| Listings | UL/cUL, CE |

AC Current Transducers

AC Current Transducer Ordering Information

Sample Model Number: ATH1-420-24U-SP
AC current transducer, time proportioned, 4-20 mA output, 24 VAC or VDC power supply, split-core case. (DIN rail adapters are included)



(1) Range

| | |
|---|--------------------|
| 0 | 2 and 5 A |
| 1 | 10, 20 and 50 A |
| 2 | 100, 150 and 200 A |

(2) Output Type

| | |
|-----|----------|
| 420 | 4–20 mA |
| 005 | 0–5 VDC |
| 010 | 0–10 VDC |

(3) Power Supply

| | |
|-----|-------------------|
| 24U | 24 VAC or VDC |
| 120 | 120 VAC (FL only) |

(4) Case Style

| | |
|----|------------|
| SP | Split-core |
| FL | Solid-core |



ATQ SERIES

Frequency Output AC Current Transducers

ATQ Series AC Current Transducers have a patented frequency output design used as an input to high-speed counter or frequency PLC modules, panel meters or programmable relays. Use where no analog inputs are available. Eight ranges, from 0–2 to 0–200 A, across three models provide the best available resolution. The ATQ Series AC Current Transducers are designed with a split-core case for easy installation.

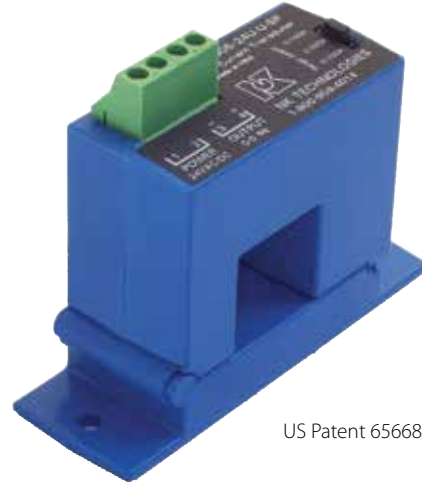

US Patent 6566855

AC Current Transducer Applications

Motion and Motor Control

- Pump, grinder, and fan motor status monitoring.
- Belt jam sensing in conveyor applications.
- Motor control in deburring/brush operations.
- Detect strain, acts as an electronic shear pin.

Current Measurement

- Measure current use in machine tools, polishing, and cutting operations where a small PLC has sufficient capacity to accept the sensor inputs measuring speed, time of use and electrical demands of the equipment.

AC Current Transducer Features

True RMS Output

- True RMS technology is accurate on distorted waveforms like VFD or SCR outputs.

Jumper-selectable Ranges

- Reduces inventory.
- Eliminates zero and span pots.

Isolation

- Output is magnetically isolated from the input for safety.
- Eliminates insertion loss (voltage drop).

Easy Installation

- Split-core case means the monitored conductor does not need to be disconnected to install the sensor.

Frequency Output Control

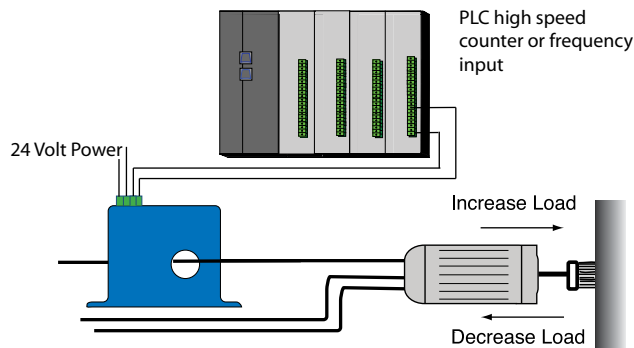

For additional Application Examples, go to www.nktechnologies.com/applications

OEMs

Test & Evaluation Units for OEMs

Free program expedites evaluation process. See page 3 for details.

AC Current Transducer Dimensions

SP Case

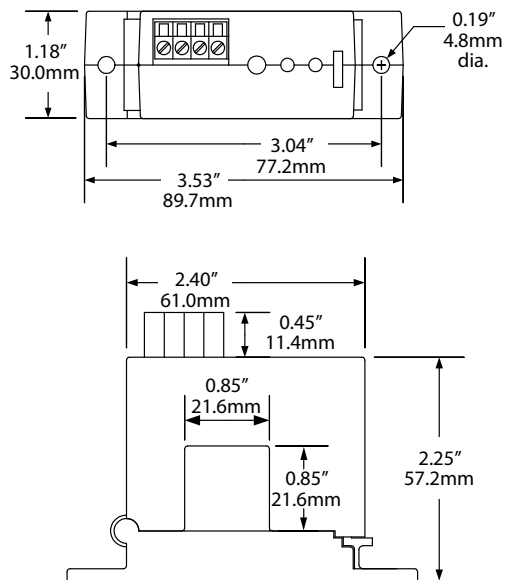

AC Current Transducer Connections

Sinking Input Connection

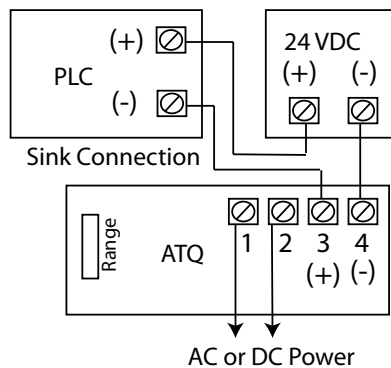

Sourcing Input Connection

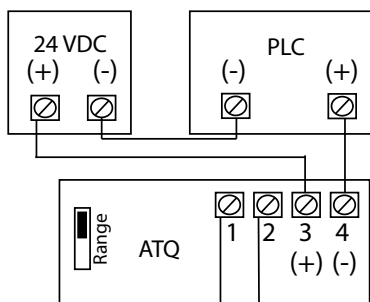

AC Current Transducer Specifications

| | |
|--------------------------|---|
| Power Supply | 24 VAC/DC (19–26 V) |
| Power Consumption | <1 VA |
| Output Signal | • 5 KHz at full range current • 10 KHz at full range current |
| Response Time | 100 ms (to 90% step change) |
| Frequency Range | 6–100 Hz |
| Input Frequency | 40–400 Hz |
| Pulse Width | On: 40 microseconds Off: Variable |
| Isolation Voltage | Tested to 5 KV |
| Case | UL94 V-0 Flammability Rated |
| Environmental | -4 to 122°F (-20 to 50°C) 0–95% RH, non-condensing |

AC Current Transducer Ordering Information

Sample Model Number: ATQ1-05K-24U-SP
AC current transducer, 5K frequency at 10, 20 or 50 A, split-core case.
(DIN rail adapters are included)



(1) Range

| | |
|---|-----------------|
| 0 | 2 and 5 A |
| 1 | 10, 20, 50 A |
| 2 | 100, 150, 200 A |

(2) Frequency Output

| | |
|-----|--------|
| 05K | 5K Hz |
| 10K | 10K Hz |

(3) Power Supply

| | |
|-----|----------------------------|
| 24U | 24 VAC/DC power (external) |
|-----|----------------------------|

(4) Case Style

| | |
|----|------------|
| SP | Split-core |
|----|------------|



ATS SERIES WITH DIGITAL SETPOINT DISPLAY

AC Current Transducer/Switch

ATS Series AC Current Sensors combine a current operated switch and transducer into a single package. The FL model features a digital display that gives visual indication of the setpoint for greater accuracy. The sensor provides a solid-state contact which will change state when the current exceeds an adjustable level or falls below the normal running current. This means reduced installation time, plus the option to have local control of a starter coil while at the same time sending the analog signal back to a controller housed in a separate cabinet.



Digital Setpoint Display
US Patent 9747776

AC Transducer/Switch Applications

Electronic Proof of Operation

- Current operated switches eliminate the need for multiple pipe or duct penetrations and are more reliable than electromechanical pressure or flow switches.

Conveyors

- Detect jams and overloads.
- Interlock multiple conveyor sections.

Pump Control

- Provides signal to measure current and shuts down the pump if the current rises over the setpoint.

Cooling Towers

- Analog monitors time of use and contact opens if a filter clogs.

Pump Jam & Suction Loss Protection

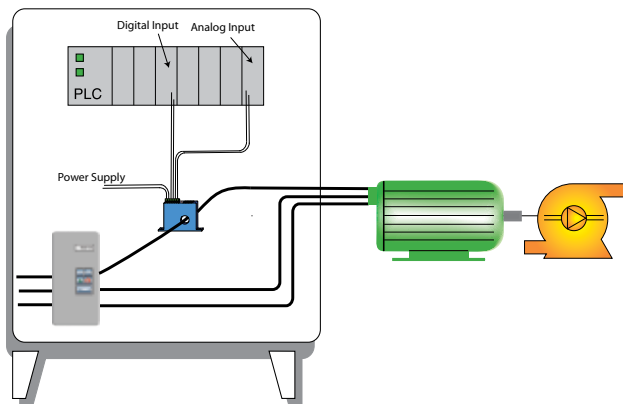

AC Transducer/Switch Features

Solid-state Output

- N.O. or N.C. solid-state switch for control circuits up to 240 VAC.
- Compatible with most automation systems.

External Powered

- Allows for higher accuracy.

Easily Adjustable and Precise Setpoint

- Speeds startup.

Analog Output

- Measures the current used at all times.

LED Display

- Provides quick visual indication of where the contact changes. Display flashes on and off when current has exceeded the setpoint.
- Easiest and most accurate setpoint adjustment available.

Built-in Mounting Feet

- Simple, two-screw panel mounting or attach with DIN rail brackets (included).*

UL/cUL and CE Approved

- Accepted worldwide.

*For information on the DIN rail accessories kit, see page 147.

- For additional Application Examples, go to www.nktechnologies.com/applications

OEMs Test & Evaluation Units for OEMs
Free program expedites evaluation process. See page 3 for details.

AC Current Transducer/Switch Dimensions

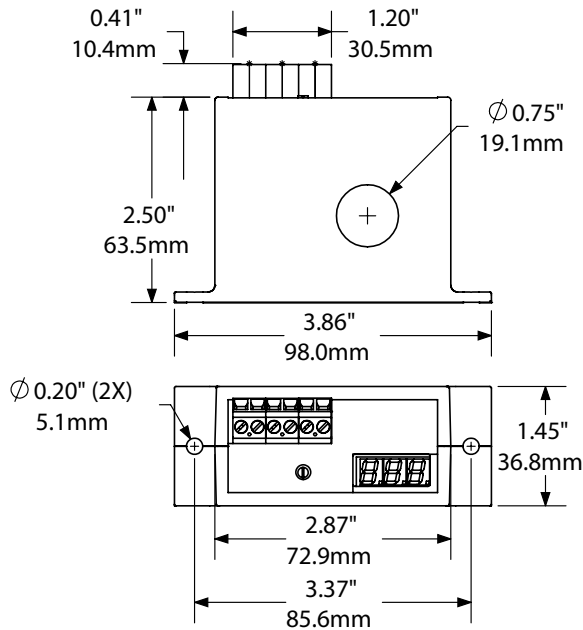

AC Current Transducer/Switch Connections

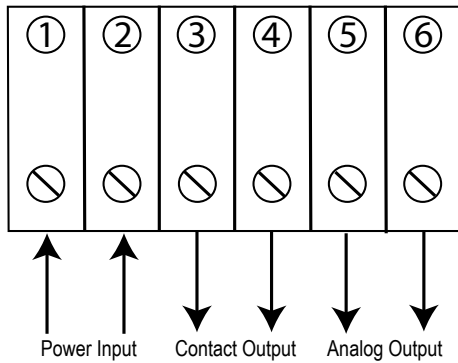

Display shows the trip point, and flashes when AC current exceeds that value. A trip point of 15 A is displayed as 015.

AC Current Transducer/Switch Specifications



| | |
|--------------------------------------|--|
| Power Supply | 24 VAC/VDC (18–28 V) |
| Power Consumption | 160 mA max |
| Input Range | <ul style="list-style-type: none"> • ATS1: 0–50 A • ATS2: 0–200 A |
| Output Signal | <ul style="list-style-type: none"> • 420: 4–20 mA DC • 005: 0–5 VDC • 010: 0–10 VDC |
| Output Limit | <ul style="list-style-type: none"> • 420: 20 mA • 005: 5 VDC • 010: 10 VDC |
| Output Loading | <ul style="list-style-type: none"> • 420: 500 Ω max. • 005: 5 KΩ min. • 010: 5 KΩ min. |
| Accuracy | +/-1.0% FS |
| Response Time (Analog Output) | Average responding <ul style="list-style-type: none"> • <250 ms 90% step change • <500 ms 99.5% step change • <2000 ms 100% step change |
| Response Time (Switch Output) | <ul style="list-style-type: none"> • <500 ms for 5% over setpoint • <200 ms for 50% over setpoint • <150 ms for 100% over setpoint |
| Hysteresis | 5% |
| Frequency Range | 40–100 Hz |
| Setpoint Range | <ul style="list-style-type: none"> • ATS1: 1–50 A (adjustable) • ATS2: 4–200 A (adjustable) |
| Output Switch | Isolated solid-state switch |
| Output Rating | 1.0 A @ 240 VAC (general use) |
| Isolation Voltage | Tested to 1480 VAC |
| Case | UL94 V-0 Flammability Rated |
| Environmental | -4 to 122°F (-20 to 50°C) Surrounding Air 0–95% RH, non-condensing |
| Listings | UL/cUL, CE |

AC Current Transducers

AC Current Transducer/Switch Ordering Information

Sample Model Number: ATS1-420-NOAC-24U-FL
Adjustable AC current operated switch/transducer, normally open, solid-core case. (DIN rail adapters are included)

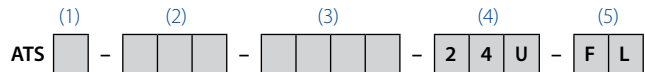

| | |
|------------------------|---|
| (1) Range | |
| 1 | 0–50 Analog, 1–50 switch adjustment |
| 2 | 0–200 Analog, 4–200 switch adjustment |
| (2) Analog Signal Type | |
| 420 | 4–20 mA (powered by sensor) |
| 005 | 0–5 VDC |
| 010 | 0–10 VDC |
| (3) Output Contact | |
| NOAC | Normally Open, closes on current rise, AC control only |
| NCAC | Normally Closed, opens on current rise, AC control only |
| (4) Power Supply | |
| 24U | 24 VAC or VDC |
| (5) Case Style | |
| FL | Solid-core |



ATS SERIES WITH ROTARY SWITCH SETPOINT

AC Current Transducer/Switch

The ATS Series AC Current Sensors combine a current operated switch and transducer into a single package for use in AC current applications up to 1200 A. The large sensing window provides complete isolation between the primary circuit and the controls. The DIN rail mounting makes installation a breeze, and provides a very secure mounting that is resistant to conductor movement.

Rotary Switch Setpoint Selection (patented setpoint adjustment) US Patent 9747776



AC Transducer/Switch Applications

Large AC Motor Loads

- Produces an analog signal at all times to detect increases or decreases in current.
- Provides limit alarm contacts for over or undercurrent conditions.
- Extra large aperture allows for single or multiple conductor passage.

Main Service Entrance

- Allows a viewer to see the amount of current used at any time when connected to a standard panel meter.

Generators

- Measure the AC current produced or consumed.
- Detect mechanical problems before failure occurs.

AC Transducer/Switch Features

Easily Established Relay Actuation Point

- Patented rotary switch setpoint selection.
- Trip point indicated on the labeling.

Isolation

- Output is magnetically isolated from the input for safety.
- Eliminates insertion losses, no added burden.

Analog Signal Available At All Times

- 4–20 mA signal proportional to 0–1200 AC A.
- Reduces components by combining transducer and limit alarm (current switch).
- Analog signal powered from the sensor; no loop powered required.

DIN Rail Mounted Case*

- Integral DIN rail mount with spring loaded mounting clips.
- Makes installation a snap.

Failsafe Relay Action

- Single Pole Double Throw Relay changes state with power to the sensor.
- LED indication if power is removed from the sensor or primary current exceeds the adjustable trip point.
- Field-adjustable time delay from 0.5 to 12 seconds.

UL/cUL Approved

- Accepted worldwide.

*For information on the DIN rail accessories kit, see page 147.

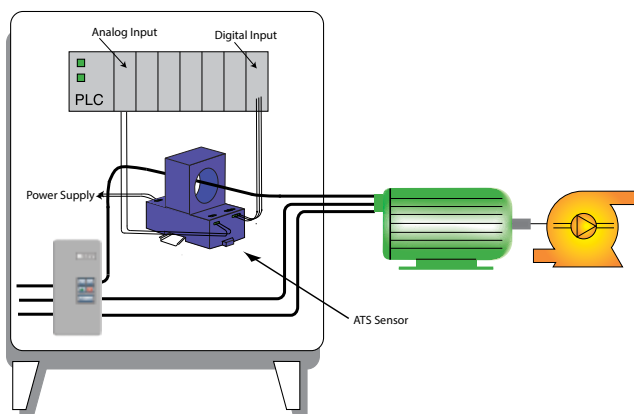

For additional Application Examples, go to www.nktechnologies.com/applications

OEMs

Test & Evaluation Units for OEMs

Free program expedites evaluation process. See page 3 for details.

AC Current Transducer/Switch Dimensions

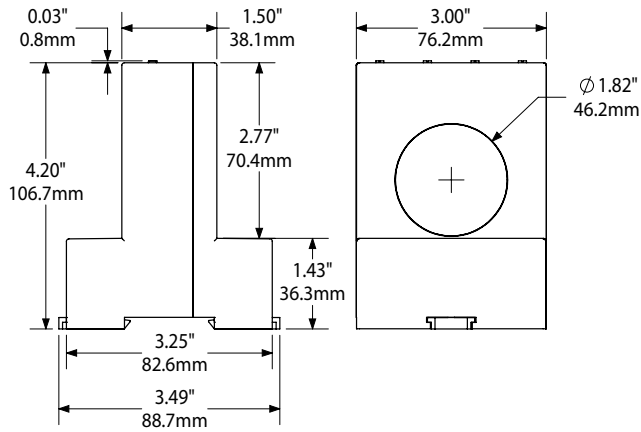

AC Current Transducer/Switch Connections

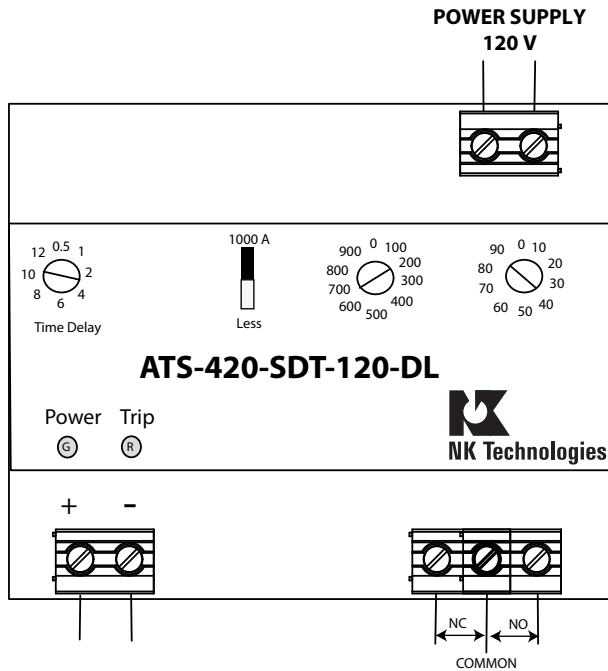

ANALOG OUTPUT SIGNAL

OUTPUT SWITCH

AC Current Transducer/Switch Output Type

Single pole, double throw relay-adjustable from 10 to 1200 A in 10 A increments. 4–20 mA signal proportional to 0–1200 A. Analog signal capped at 6 mA when trip point <150 A, 8 mA if trip point <300 A, 23 mA if the trip point is 310 A or higher.

Notes:

Dead front captive screw terminals.
12–22 AWG solid or stranded.
Observe polarity.

AC Current Transducer/Switch Specifications



| | |
|-----------------------------|---|
| Power Supply | • 120 VAC (108–132 V) • 24 VDC (22–26 V) |
| Power Consumption | <2 VA |
| Input Range | 0–1200 A |
| Output Signal | 4–20 mA |
| Output Limit | 23 mA |
| Output Loading | 600 Ω maximum |
| Accuracy | 2% FS |
| Analog Response Time | 600 ms to 90% step change |
| Hysteresis | 5% |
| Frequency Range | 10–100 Hz |
| Setpoint Range | 10–1200 A |
| Output Switch | Electromechanical SPDT relay |
| Output Rating | 1.0 A @ 125 VAC, 2 A @ 30 VDC |
| Time Delay | 0.5–12 sec. (adjustable) |
| Isolation Voltage | UL listed to 2200 VAC |
| Case | UL94 V-0 Flammability Rated |
| Environmental | -4 to 122°F (-20 to 50°C) Surrounding Air 0–95% RH, non-condensing |
| Listings | UL/cUL |

AC Current Transducers

AC Current Transducer/Switch Ordering Information

Sample Model Number: **ATS-420-SDT-24D-DL**
Solid-core AC current operated switch/transducer combination, 0–1200 A range, 4–20 mA analog output, 24 VDC powered, adjustable relay trip point.

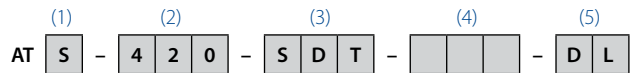

| | | |
|----------------------|-----|--|
| (1) Full Scale Range | S | Combination (switch and transducer) 0-1200 A |
| (2) Output Signal | 420 | 4–20 mA Note: maximum output depends on setpoint |
| (3) Contact Type | SDT | SPDT Relay |
| (4) Power Supply | 24D | 24 VDC |
| | 120 | 120 VAC |
| (5) Case Style | DL | Solid-core, DIN rail mounting |



DC Current Transducers

Current Transducers are designed to provide an analog current reading for monitoring, data logging and panel meter applications. NK Technologies' current transducers offer a choice of 0–5 VDC, 0–10 VDC or 4–20 mA outputs common to PLC and energy management system controllers for monitoring of DC motor conditions, solar panel installations, welding processes and transportation applications.

Features:

- Jumper-selectable ranges
- Solid-core, split-core and large aperture models

- **DT SERIES, 4-WIRE Split-Core**
DC Current Transducers..... page 73
- **DT SERIES, 4-WIRE Solid-Core**
DC Current Transducers..... page 76
- **DT SERIES, 3-WIRE**
DC Current Transducers..... page 78
- **DT SERIES, 5 & 12 VDC POWERED**
DC Current Transducers..... page 80
- **DT-FD SERIES, HIGH VOLTAGE**
DC Current Transducers..... page 82
- **DT-BB SERIES, Bus Bar or Panel Mounted**
DC Current Transducers..... page 84
- **DT-DL SERIES, LARGE APERTURE**
DC Current Transducers..... page 86
- **DLT SERIES, 2-WIRE Looped Power**
DC Current Transducers..... page 88

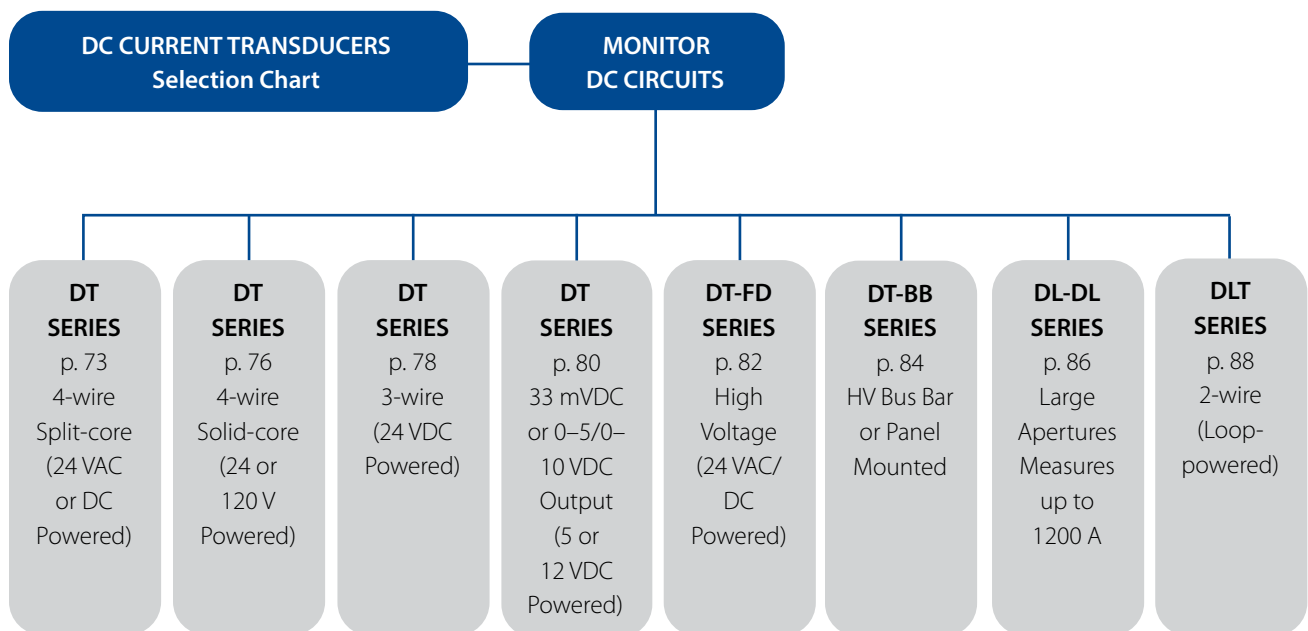

DT SERIES, 4-WIRE SPLIT-CORE

DC Current Transducers

DT Series DC Current Transducers combine a Hall effect sensor and signal conditioner into a single package for use in DC current applications up to 400 A. The DT Series DC Current Transducers unipolar and bipolar models have jumper-selectable current input ranges and industry standard 0–20 mA, 4–20 mA, 0–5 VDC or 0–10 VDC outputs. Bidirectional output models provide a single range. These transducers are available in a split-core case.



DC Current Transducer Applications

Battery Banks

- Monitor load current.
- Monitor charging current.
- Verify operation.

Transportation

- Measure traction power or auxiliary loads.

Welding Processes

- Measure the current used while welding.
- Log processing time and number of operations.

Photovoltaic Panels

- Monitor panel or string current output.
- Monitor combiner box output.

DC Current Transducer Features

Single Range or Three Jumper-selectable Ranges

- Reduces set-up time.
- Reduces inventory.
- Eliminates zero and span pots.

Isolation

- Output is magnetically isolated from the input for safety.
- Eliminates insertion loss (voltage drop).

Internal Power Regulation

- Works well, even with unregulated power.
- Cuts installation cost.

Split-core Design/Built-in Mounting Brackets

- Makes installation a snap.

UL/cUL and CE Approved

- Accepted worldwide.

Battery Charging System - Bipolar Output

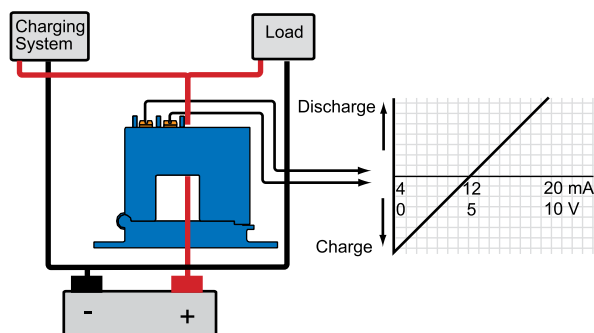

Battery Charging System - Bidirectional Output

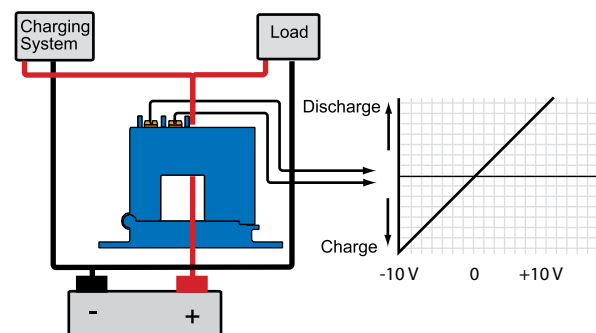

- For additional Application Examples, go to www.nktechnologies.com/applications

OEMs

Test & Evaluation Units for OEMs

Free program expedites evaluation process. See page 3 for details.



DT SERIES, 4-WIRE

292000206 Rev 2

DC Current Transducer Dimensions

SP Case

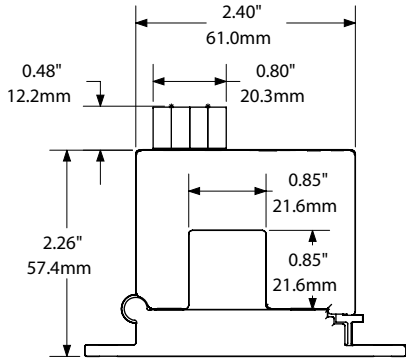
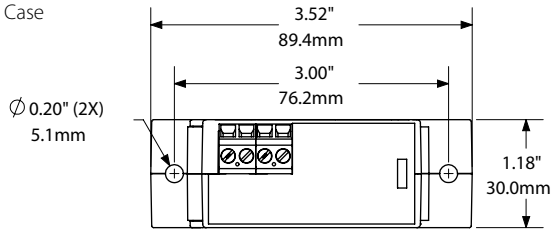

DC Current Transducer Output

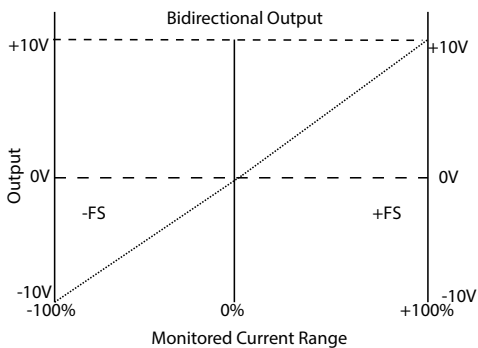
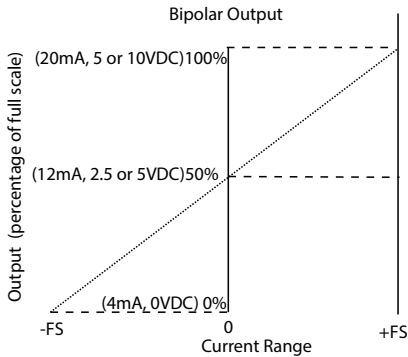
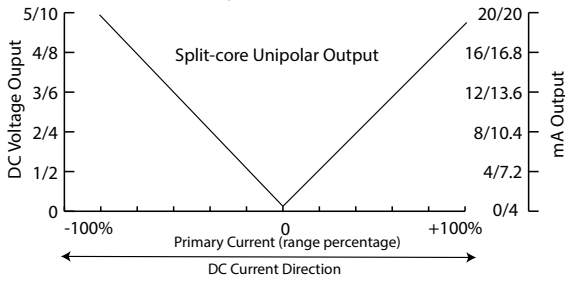

DC Current Transducer Specifications



| | |
|--------------------------|---|
| Power Supply | • 24 VAC/VDC (20–45 VDC, 22–38 VAC) • 24 VDC (20-45 VDC Bidirectional models only) |
| Power Consumption | 2 VA |
| Output Signal | • 0–20 mA, 4–20 mA, 0–5 VDC, 0–10 VDC • ±10 VDC (Bidirectional models only) |
| Output Limit | • 0–20 mA, 4–20 mA: 23 mA • 0–5 VDC: 5.75 VDC • 0–10 VDC: 11.5 VDC |
| Output Loading | • 0–20 mA, 4–20 mA: 500 Ω max. • 0–5 VDC: 25 KΩ min. • 0–10 VDC: 50 KΩ min. |
| Accuracy | 2.0% FS |
| Repeatability | 1.0% FS |
| Response Time | • 60 ms (90% step change) • 100 ms (Bidirectional models only) |
| Frequency Range | DC |
| Isolation Voltage | Tested to 3 KV |
| Input Range | 0–50 A min., 0–400 A max. |
| Case | UL94 V-0 Flammability Rated |
| Environmental | -4 to 122°F (-20 to 50°C) 0–95% RH, non-condensing |
| Listings | UL/cUL, CE |

DC Current Transducer Connections

DT Series Unipolar and Bipolar Output Models

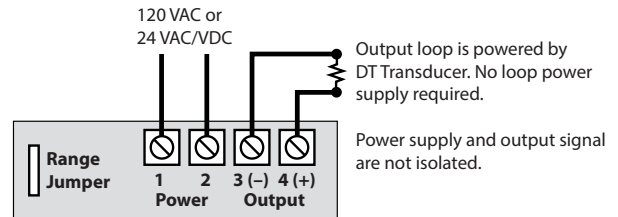

DT Series Bidirectional Output Models

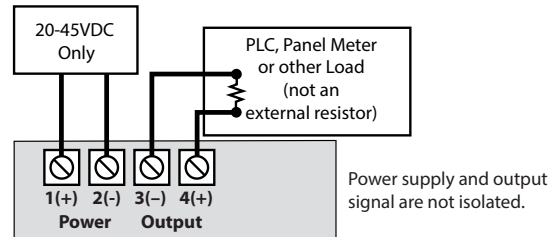

Notes:
Deadfront captive screw terminals.
30-12 AWG solid or stranded.
Observe polarity.

DC Current Transducer Ordering Information

DT Series Unipolar and Bipolar Output Models

Sample Model Number: DT2-420-24U-U-SP

DC current transducer, 0–100/150/200 A range, 4–20 mA output, 24 VAC/DC powered, unipolar polarity, split-core case. (DIN rail adapters are included)

DT ⁽¹⁾ [] - ⁽²⁾ [][] - ⁽³⁾ 2 4 U - ⁽⁴⁾ [][] - ⁽⁵⁾ S P

(1) Full Scale Range

| | |
|---|-----------------|
| 1 | 50, 75, 100 A |
| 2 | 100, 150, 200 A |
| 3 | 150, 225, 300 A |
| 4 | 200, 300, 400 A |

(2) Output Signal

| | |
|-----|----------|
| 020 | 0–20 mA |
| 420 | 4–20 mA |
| 005 | 0–5 VDC |
| 010 | 0–10 VDC |

(3) Power Supply

| | |
|-----|------------|
| 24U | 24 VAC/VDC |
|-----|------------|

(4) Output Polarity

| | |
|----|--|
| U | Unipolar (output with current in either direction) |
| BP | Bipolar |

(5) Case Style

| | |
|----|------------|
| SP | Split-core |
|----|------------|

DT Series Bidirectional Output Models

Sample Model Number: DT2-010-24D-BD-SP

DC current transducer, 0–200 A range, ±10 VDC output signal, 24 VDC powered, split-core case. (DIN rail adapters are included)

DT ⁽¹⁾ [] - ⁽²⁾ 0 1 0 - ⁽³⁾ 2 4 D - ⁽⁴⁾ B D - ⁽⁵⁾ S P

(1) Full Scale Range

| | |
|---|-------|
| 1 | 100 A |
| 2 | 200 A |
| 3 | 300 A |
| 4 | 400 A |

(2) Output Signal

| | |
|-----|---------|
| 010 | ±10 VDC |
|-----|---------|

(3) Power Supply

| | |
|-----|--------|
| 24D | 24 VDC |
|-----|--------|

(4) Output Polarity

| | |
|----|---------------|
| BD | Bidirectional |
|----|---------------|

(5) Case Style

| | |
|----|------------|
| SP | Split-core |
|----|------------|



DT SERIES, 4-WIRE SOLID-CORE DC Current Transducers

DT Solid-core Series DC Current Transducers combine a Hall effect sensor and signal conditioner into a single package for use in DC current applications up to 200 A. The DT Series DC Current Transducers unipolar and bipolar models have jumper-selectable current input ranges and industry standard 0–20 mA, 4–20 mA, 0–5 VDC or 0–10 VDC outputs. Solid-core models are offered with ranges as low as 0–5 amps, and up to 0–200 amps.

DC Current Transducer Applications

Battery Banks

- Monitor load current.
- Monitor charging current.
- Verify operation.

Transportation

- Measure traction power or auxiliary loads.

Welding Processes

- Measure the current used while welding.
- Log processing time and number of operations.

Photovoltaic Panels

- Monitor panel or string current output.
- Monitor combiner box output.

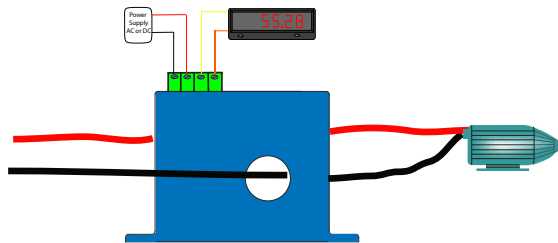

Use a DT sensor over one lead to a DC motor to measure the current used. Over normal readings mean a jam or a bearing failure, and under normal current means a belt or coupling may have broken. The output can also be used to measure time of use to help with maintenance scheduling.

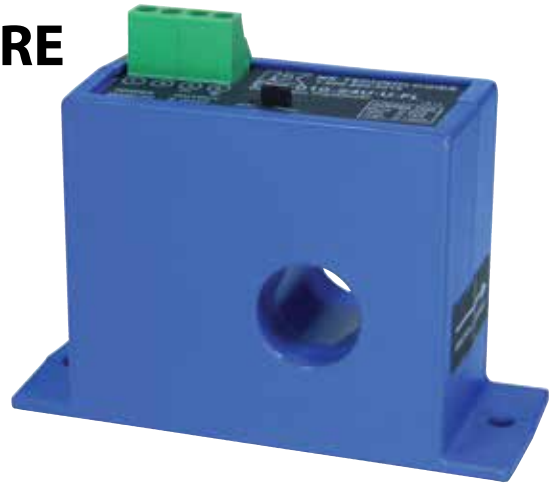

DC Current Transducer Features

Three Jumper-selectable Ranges

- Reduces set-up time.
- Reduces inventory.
- Eliminates zero and span pots.

Isolation

- Output is magnetically isolated from the input for safety.
- Eliminates insertion loss (voltage drop).

Internal Power Regulation

- Works well, even with unregulated power.
- Cuts installation cost.

Solid-core Design/Built-in Mounting Brackets

- Makes installation a snap.

UL/cUL and CE Approved

- Accepted worldwide.

DC Current Transducer Output

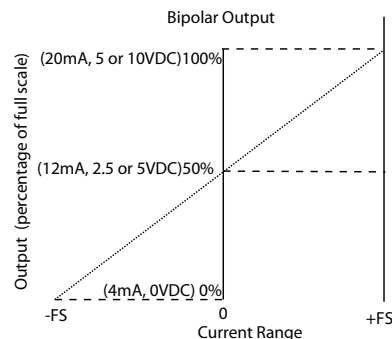
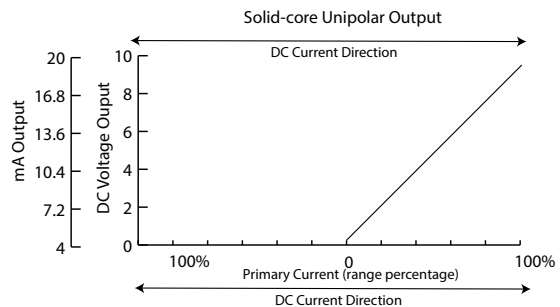

OEMs

Test & Evaluation Units for OEMs

Free program expedites evaluation process. See page 3 for details.

DC Current Transducer Dimensions

FL Case

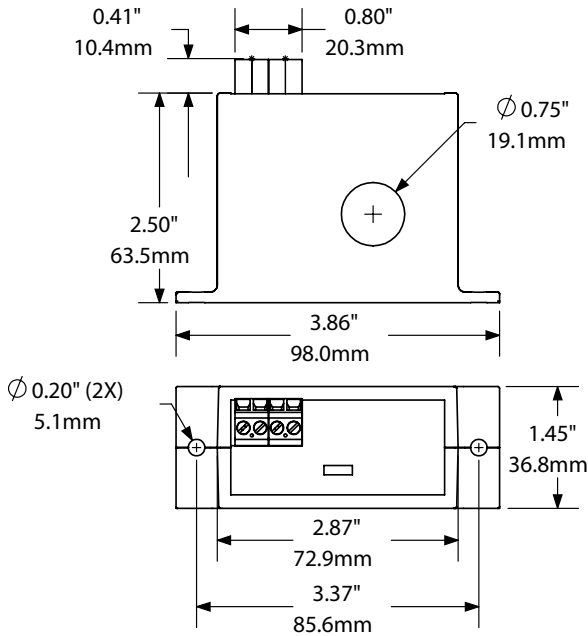

DC Current Transducer Specifications



| | |
|--------------------------|---|
| Power Supply | • 120 VAC (108–132 V) • 24 VAC/VDC (22–26 V) |
| Power Consumption | 2 VA |
| Output Signal | • 0–20 mA, 4–20 mA, 0–5 VDC, 0–10 VDC |
| Output Limit | • 0–20 mA, 4–20 mA: 23 mA • 0–5 VDC: 5.75 VDC • 0–10 VDC: 11.5 VDC |
| Output Loading | • 0–20 mA, 4–20 mA: 500 Ω max. • 0–5 VDC: 25 KΩ min. • 0–10 VDC: 50 KΩ min. |
| Accuracy | 1.0% FS |
| Repeatability | 1.0% FS |
| Response Time | 60 ms (to 90% of step change) |
| Frequency Range | DC |
| Isolation Voltage | Tested to 3 KV |
| Input Range | 0–200 A max |
| Case | UL94 V-0 Flammability Rated |
| Environmental | -4 to 122°F (-20 to 50°C) 0–95% RH, non-condensing |
| Listings | UL/cUL, CE (120 VAC model not UL listed) |

DC Current Transducers

DC Current Transducer Connections

DT Series Unipolar and Bipolar Output Models

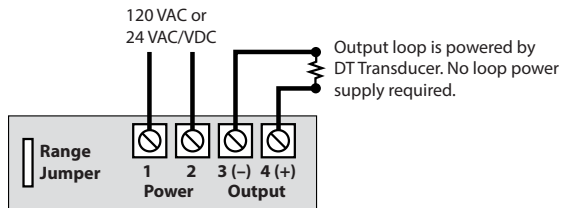

Notes:
Deadfront captive screw terminals.
30-12 AWG solid or stranded.
Observe polarity.

DC Current Transducer Ordering Information

Sample Model Number: DT2-420-24U-U-FL
DC current transducer, 0–100/150/200 A range, 4–20 mA output, 24 VAC/VDC powered, unipolar polarity, solid-core case. (DIN rail adapters are included)



(1) Full Scale Range

| | |
|---|-----------------|
| 0 | 5, 10, 20 A |
| 1 | 50, 75, 100 A |
| 2 | 100, 150, 200 A |

(2) Output Signal

| | |
|-----|---------|
| 020 | 0–20 mA |
| 420 | 4–20 mA |
| 005 | 0–5 VDC |
| 010 | 10 VDC |

(3) Power Supply

| | |
|-----|------------|
| 24U | 24 VAC/VDC |
| 120 | 120 VAC |

(4) Output Polarity

| | |
|----|--|
| U | Unipolar (output with current in one direction only) |
| BP | Bipolar |

(5) Case Style

| | |
|----|------------|
| FL | Solid-core |
|----|------------|



DT SERIES, 3-WIRE

DC Current Transducers

DT Series DC Current Transducers provide a low cost way of measuring DC current in a small and easy-to-install case. The series is stable at a wide range of temperatures. The single range design and the use of a common for the power supply and output signal provide a price competitive option in an international market. Similar in concept to the DLT current output sensors, this design produces a choice of 0–5 or 0–10 VDC to interface with controllers or data acquisition systems lacking the current signal capacity.



DC Current Transducer Applications

Photovoltaic Panel Monitoring

- Accurate and reliable indication of how much power is produced by a single panel or a string of panels.

Hoists

- Detect overloads and jams.
- Detect undercurrent conditions from coupling slip or breakage.

DC Motor Protection

- Detect imminent bearing failures.

Wind Driven Generators

- Measure and monitor power production from alternative sources.

Monitoring a Photovoltaic Panel Power Output

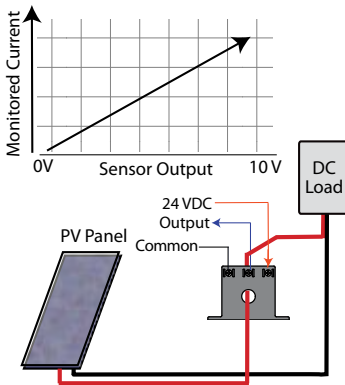

- For additional Application Examples, go to www.nktechnologies.com/applications

DC Current Transducer Features

Industry Standard Outputs

- 0–5 or 0–10 VDC proportional to the DC current.
- Compatible with most automation systems.

24 VDC Powered

- Power supply and output share common.

No Span or Zero Adjustments Needed

- Reduces field calibration errors.
- Factory calibrated without potentiometers.

Solid-core Case

- Compact size requiring very little panel space.

Built-in Mounting Feet

- Simple, two-screw panel mounting or attach with DIN rail brackets (included).*

Designed for UL/cUL and CE Approval

- Accepted worldwide.

*For information on the DIN rail accessories kit, see page 147.

OEMs

Test & Evaluation Units for OEMs

Free program expedites evaluation process. See page 3 for details.

DC Current Transducer Dimensions

FF Case

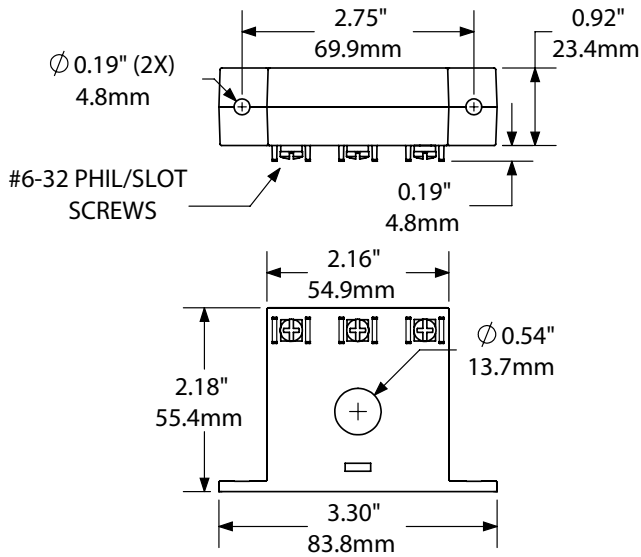

DC Current Transducer Connections

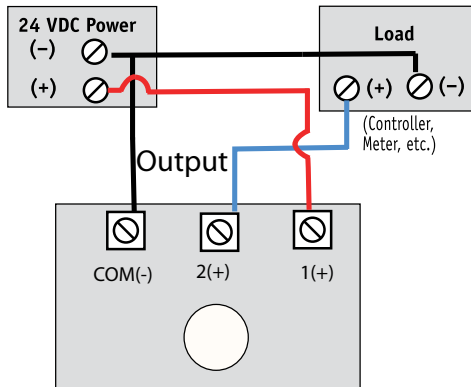

DC Current Transducer Specifications

| | |
|-------------------|---|
| Power Supply | 24 VDC (19–30 V) |
| Power Consumption | <2 VA |
| Output Signal | 0–5 or 0–10 VDC |
| Accuracy | 1% full scale |
| Output Loading | 10 KΩ min. |
| Response Time | 500 ms |
| Input Range | • 0–50 A • 0–100 A |
| Frequency Range | DC |
| Isolation Voltage | Tested to 3 KV |
| Case | UL94 V-0 Flammability Rated |
| Environmental | -4 to 122°F (-20 to 50°C) 0–95% RH, non-condensing |
| Listings | Designed for UL/cUL and CE approval |

DC Current Transducer Ordering Information

Sample Model Number: DTB-010-24D-U-FF

DC current transducer, 0–50 A, 0–10 VDC output, 24 VDC powered, unipolar, solid-core case. (DIN rail adapters are included)

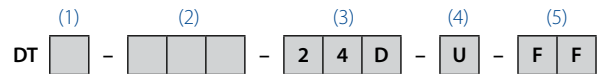

(1) Range

| | |
|---|-----------|
| B | 0–50 ADC |
| C | 0–100 ADC |

(2) Output Type

| | |
|-----|----------|
| 005 | 0–5 VDC |
| 010 | 0–10 VDC |

(3) Power Supply

| | |
|-----|--------|
| 24D | 24 VDC |
|-----|--------|

(4) Output Design

| | |
|---|---|
| U | Unipolar (output with current in one direction) |
|---|---|

(5) Case Style

| | |
|----|-----------------------------|
| FF | Solid-core, front terminals |
|----|-----------------------------|



DT SERIES, 5 & 12 VDC POWERED DC Current Transducers

The DT Series of Temperature Compensated DC Current Transducers is ideal for energy management system inputs where the controller is designed to accept 333 mV signals, commonly found in power monitoring applications. Other output options available are a 0–5 VDC signal used in building energy management systems or a 0–10 VDC signal seen more often in industrial controllers. Additionally, this series features a patented method that improves the sensor accuracy as the ambient temperature changes. The sensor output is automatically adjusted as the temperature increases or decreases, eliminating one of the biggest issues with Hall effect based products.



Patented temperature compensation design
US Patent 9618541

DC Current Transducer Applications

Photovoltaic Panel Output Measurement

- The sensor output rises and falls as the panel produces more or less power.

DC Motors

- Detect jams and overloads.
- Provide early notification of impending bearing failure.

Electrical Heaters

- Detect open or shorted elements quickly.

Photovoltaic Panel Output Measurement

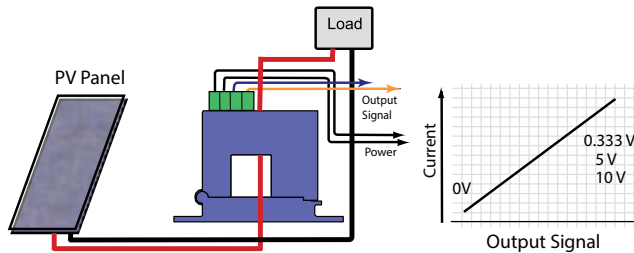

The DT sensor will produce a signal directly proportional to the current produced by the panel or string of panels, with an output to match the controller being used.

- For additional Application Examples, go to www.nktechnologies.com/applications

DC Current Transducer Features

Voltage Output

- 333 mVDC, 5 or 10 VDC proportional to DC current.
- Compatible with many monitoring systems.

5 VDC Powered

- Use with data collection systems.
- Available with 333 mVDC output.

12 VDC Powered

- Available with 0.333, 5 or 10 VDC output.

Ranges to Suit Your Needs

- 0–50 A DC.
- 0–100 A DC.

Temperature Compensated

- Remains accurate with rise or fall of ambient temperature.

Built-in Mounting Feet

- Simple, two-screw panel mounting or attach with DIN rail brackets (included).*

Split-core Case

- Open to snap the sensor over existing conductor; no need to disconnect the load to install.

Designed for UL/cUL and CE Approval

- Accepted worldwide.

*For information on the DIN rail accessories kit, see page 147.

OEMs Test & Evaluation Units for OEMs
Free program expedites evaluation process. See page 3 for details.

DC Current Transducer Dimensions

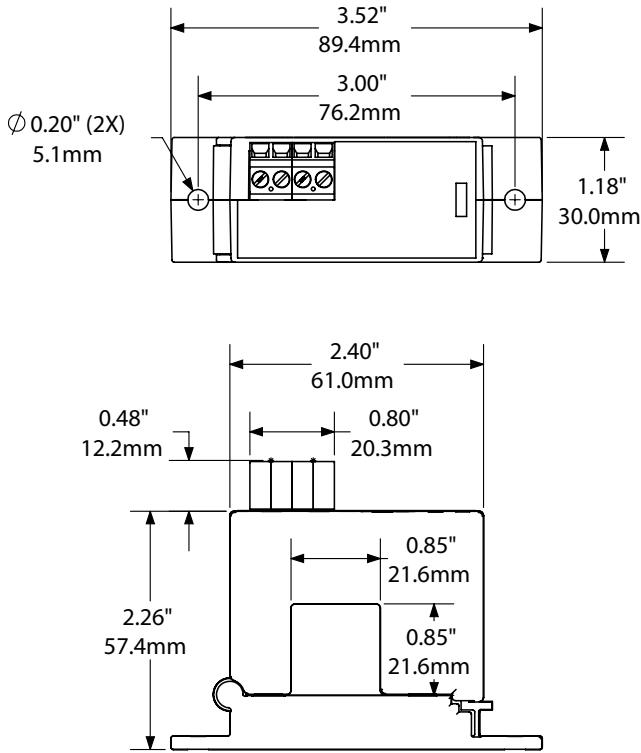

DC Current Transducer Connections

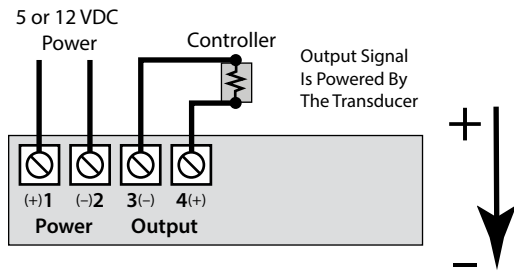

DC Current Transducer Output

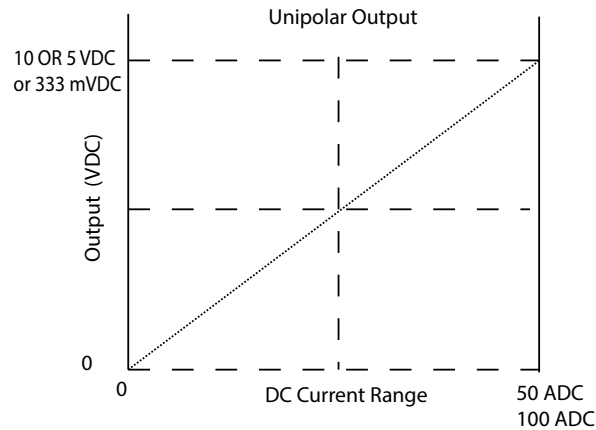

Output remains accurate even as the temperature rises and falls from -20°C to +50°C (-4 to +122 °F) with our patented design.

DC Current Transducer Specifications

| | | |
|--------------------------|---|--|
| Power Supply | 5 VDC (5.1–5.9 V) | 12 VDC (11.5–13.2 V) |
| Power Consumption | <2 VA | <2 VA |
| Output Signal | 0–333 mVDC | 0–5 VDC or 0–10 VDC |
| Output Loading | 50 Ω minimum, (333 mVDC output) | 10 K Ω minimum (0–5 or 0–10 VDC output) |
| Accuracy | 1.0% full scale across temperature range | |
| Response Time | 400 ms (90% step change) | |
| Frequency Range | DC | |
| Isolation Voltage | Tested to 3 KV | |
| Case | UL94 V-0 Flammability Rated | |
| Environmental | -4 to 122°F (-20 to 50°C) 0–95% RH, non-condensing | |
| Listings | Designed for UL/cUL and CE approval | |

DC Current Transducer Ordering Information

Sample Model Number: DTB-333-05D-U-SP
 Split-core DC current transducer, 0–50 A range, 0–333 mVDC, 5 VDC powered, unipolar output. (DIN rail adapters are included)

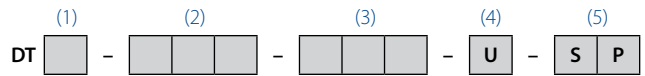

(1) Range

| | |
|---|---------|
| B | 0–50 A |
| C | 0–100 A |

(2) Output Signal

| | |
|-----|----------|
| 333 | 333 mVDC |
| 005 | 5 VDC |
| 010 | 10 VDC |

(3) Power Supply

| | |
|-----|---|
| 05D | 5 VDC (0–0.333 VDC output only) |
| 12D | 12 VDC (0–0.333, 0–5 or 0–10 VDC output only) |

(4) Signal Response Type

| | |
|---|--|
| U | Unipolar (output with current in one direction only) |
|---|--|

(5) Case Style

| | |
|----|------------|
| SP | Split-core |
|----|------------|



DT-FD SERIES, HIGH VOLTAGE DC Current Transducers

DT-FD series DC Current Transducers provide a large sensing window and the ability to monitor circuits with voltages up to 1500 VDC. The sensor can be mounted on a DIN rail or be attached to a back panel with screws. Easily accessible power supply and output-signal; finger-safe terminals are located on the top of the sensor to allow for a clean and trouble-free installation. The one-piece design combines the current sensing elements and the signal conditioning to provide an output compatible with most control systems, increasing the safety and accuracy of the installation.



DC Current Transducer Applications

Monitor Large Solar Panel Installations

- Large utility connected photovoltaic generation systems will often produce DC power at higher voltages as the wire can be smaller for the same amount of power produced.

Monitor DC Motors

- Traction and drilling equipment use higher voltage DC motors to produce high torque output at low speeds.

Solar Array Application

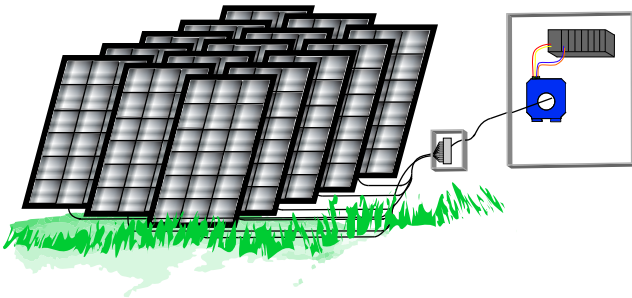

Commercial and industrial ground mounted solar arrays are connected in series to combiner boxes, developing higher voltage and lower current to deliver the same power as with a lower voltage system.

DC Current Transducer Features

Industry Standard Analog Output

- Interfaces with PLCs, panel meters and data acquisition systems quickly, with simple programming by the installer.
- Compatible with most automation and control systems.

Externally Powered

- 24 VAC or VDC (output not isolated from the power supply).

No Need For Span or Range Adjustment

- Factory set calibration reduces setup time.
- Warranted to produce accurate signals for five years. (Our decades of experience designing and producing DC current transducers shows that the calibration stays accurate for many years beyond the warranty period).

Large Solid-core Case

- Sensing window provides ample space for single or multiple conductors.

DIN Rail or Panel Mount

- Simply snap onto DIN rail or attach with screws to a panel.*

UL/cUL and CE Approved

- Accepted worldwide.

*For information on the DIN rail accessories kit, see page 147.

DC Current Transducer Dimensions

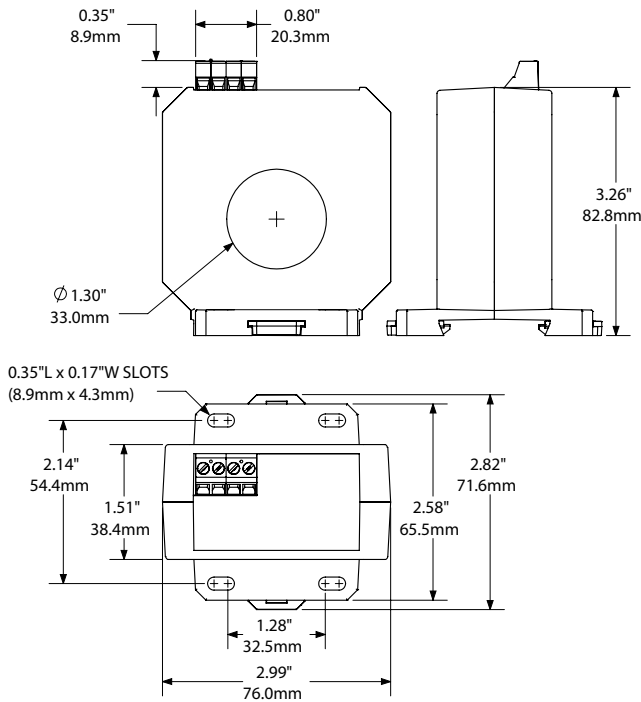

DC Current Transducer Specifications



| | | | | | | | |
|--------------------------|--|---|-----------|---|-----------|---|-----------|
| Power Supply | 24VAC/VDC (22–26 V) (Not isolated from output signal.) | | | | | | |
| Power Consumption | <3 VA | | | | | | |
| Output Signal | <ul style="list-style-type: none"> • Unipolar (output with DC current in both directions) • Bipolar (output 4–12–20 mA, 0–2.5–5 V or 0–5–10 V) • Bidirectional (output +/-5 or +/-10 VDC) | | | | | | |
| Output Limits | 20.8 mA, 5.25 or 10.5 VDC (model dependent) | | | | | | |
| Accuracy | 1.0% FS | | | | | | |
| Response Time | 150 ms maximum | | | | | | |
| Input Range | <table border="1"> <tr> <td>2</td> <td>0–200 ADC</td> </tr> <tr> <td>3</td> <td>0–300 ADC</td> </tr> <tr> <td>4</td> <td>0–400 ADC</td> </tr> </table> | 2 | 0–200 ADC | 3 | 0–300 ADC | 4 | 0–400 ADC |
| 2 | 0–200 ADC | | | | | | |
| 3 | 0–300 ADC | | | | | | |
| 4 | 0–400 ADC | | | | | | |
| Working Voltage | 1500 VDC | | | | | | |
| Isolation Voltage | Tested to 5375 VAC | | | | | | |
| Frequency Range | DC | | | | | | |
| Environmental | -4 to 122°F (-20 to 50°C) 0–95% RH, non-condensing | | | | | | |
| Listings | UL/cUL, CE | | | | | | |

DC Current Transducers

DC Current Transducer Output

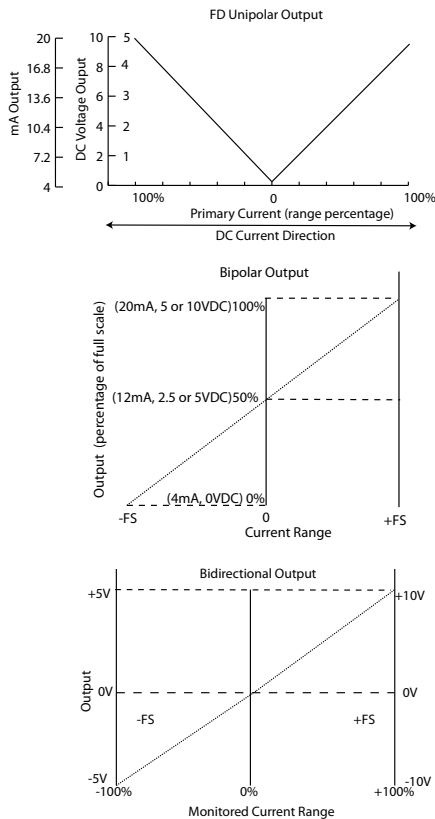

DC Current Transducer Ordering Information

Sample Model Number: DT2-420-24U-BP-FD
DC Current transducer, 0–200 A range, 4–20 mA output, 24 VAC/VDC powered, bipolar, large solid-core, DIN rail or panel mount case.



(1) Range

| | |
|---|-----------|
| 2 | 0–200 ADC |
| 3 | 0–300 ADC |
| 4 | 0–400 ADC |

(2) Output Signal

| | |
|-----|--|
| 420 | 4–20 mA (U and BP only) (500 Ω load maximum) |
| 005 | 0–5 VDC (U/BP=2 KΩ, BD=3 KΩ load minimum) |
| 010 | 0–10 VDC (U/BP=2 KΩ, BD=3 KΩ load minimum) |

(3) Power Supply

| | |
|-----|------------|
| 24U | 24 VAC/VDC |
|-----|------------|

(4) Output Type

| | |
|----|---|
| U | Unipolar (output with current flowing in both directions) |
| BP | Bipolar (output indicates current flow direction) |
| BD | Bidirectional (output is positive with current in one direction, negative with current in the opposite direction) |

(5) Case

| | |
|----|--|
| FD | Large, solid-core, DIN rail or panel mount |
|----|--|



DT-BB SERIES

DC Current Transducers

The newest DC current Transducers provide several features not previously available. This innovative design allows a split-core transducer to be installed over existing bus bars or wire, it can be mounted on a panel or DIN rail and is rated to measure DC current working voltage to 1500 VDC. The power supply and output signal wires are connected to the sensor with a terminal block which plugs into the header on the top of the sensor. Four ranges are available from 0–100 to 0–400 amps; three output types: unipolar, bipolar and bidirectional; and three industry standard outputs: 4–20 mA, 0–5 and 0–10 VDC. The Innovative design puts the current sensing components in one housing with the signal conditioning, reducing installation time and improving both accuracy and safety.

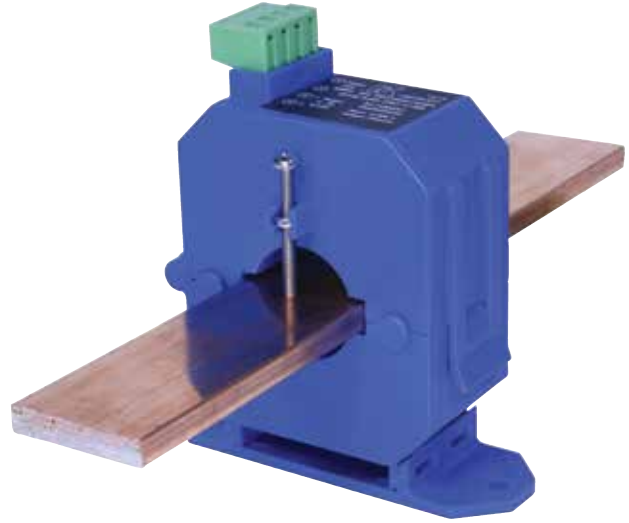

Current Transducer Applications

Grid Connected PV Solar Generation

- Measure the power produced by a number of panels connected together, at voltages to 1500 VDC.

DC Motor Monitoring

- Spot overcurrent conditions before the machine fails.
- Sense clogged filters or blocked intake to DC driven pumps.

Solar Panel Grid

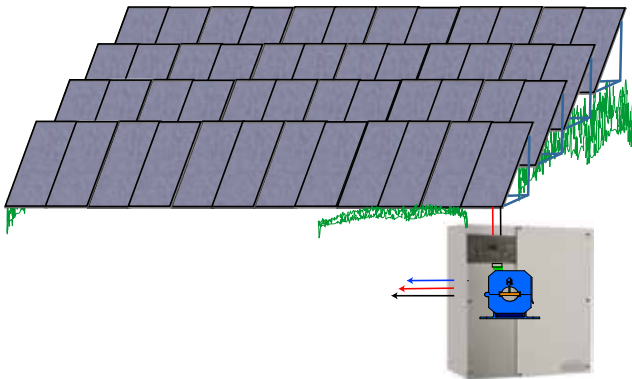

Power supply and output wires connect to the sensor with pluggable terminals, making installation even easier. Panel mounting bracket snaps on if needed.

Current Transducer Features

Standard Signal Outputs

- 4–20 mA unipolar or 4–12–20 mA bipolar output.
- 0–5/10 VDC unipolar or 0–2.5–5 VDC or 0–5–10 VDC bipolar output.
- +/-5 or +/-10 VDC bidirectional output also available.
- Compatible with most automation and control systems.

Externally Powered

- Low voltage 24 VAC/DC is safe and readily available.

Split-core Case

- Sensing window provides ample space for bus bar, single or multiple conductors.

DIN Rail or Panel Mount

- Attach to a bus assembly, snap onto DIN rail* (using available adapters) or attach with screws to a panel for secure mounting.

Designed for UL, cUL and CE Approval

- Accepted worldwide.

*For information on the DIN rail accessories kit, see page 147.

OEMs

Test & Evaluation Units for OEMs

Free program expedites evaluation process. See page 3 for details.

Current Transducer Dimensions

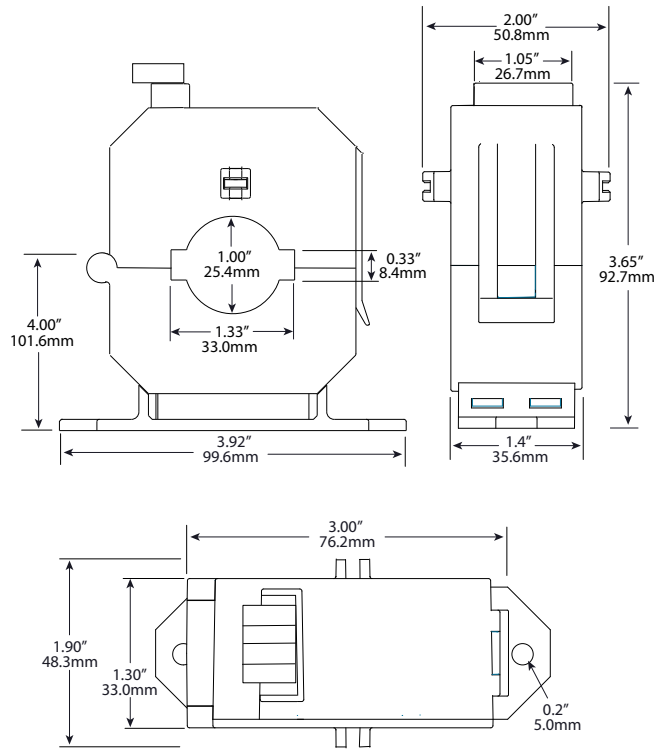

Current Transducer Connections

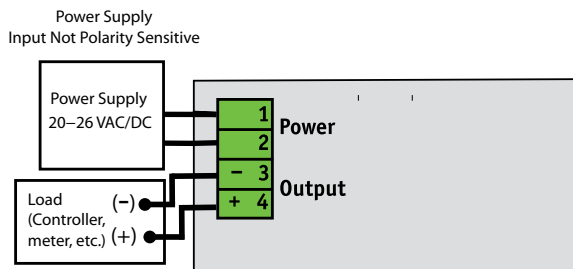

Current Transducer Specifications

| | |
|-------------------------------|---|
| Power Supply | 24 VAC/DC (20-26 V) Power and signal are not isolated. |
| Consumption | <2 VA |
| Output | 0-5 VDC, 0-10 VDC or 4-20 mA Bidirectional models: +/-5 or +/-10 VDC |
| Output Limits accuracy | 4-20 mA : 23 mA 0-5 VDC : 5.75 VDC 0-10 VDC : 11.5 VDC |
| Response Time | 40 ms (90% step change) |
| Input Ranges | 1 0-100 A 2 0-200 A 3 0-300 A 4 0-400 A |
| Isolation | Working voltage to 1500 VDC |
| Frequency Range | DC |
| Case | UL94 V0 Flammability Rated |
| Environmental | -4 to 122°F (-20 to 50°C) 0-95% RH, non-condensing |
| Listings | Designed for UL/cUL and CE approval |

Ordering Information

Sample Model Number: DT4-010-24U-BD-BB
DT Current transducer, 0-400 amp range, 24 volt powered, bidirectional output signal, split-core, bus bar mounting.



(1) Range

| | |
|---|---------|
| 1 | 0-100 A |
| 2 | 0-200 A |
| 3 | 0-300 A |
| 4 | 0-400 A |

(2) Output

| | |
|-----|----------|
| 005 | 0-5 VDC |
| 010 | 0-10 VDC |
| 420 | 4-20 mA |

(3) Power Supply

| | |
|-----|-----------|
| 24U | 24 VAC/DC |
|-----|-----------|

(4) Output Type

| | |
|----|---------------|
| U | Unipolar |
| BP | Bipolar |
| BD | Bidirectional |

(5) Case Style

| | |
|----|-------------------------------------|
| BB | Split-core, buss bar or panel mount |
|----|-------------------------------------|



DT-DL SERIES, LARGE APERTURE DC Current Transducers

DT Series Large Aperture DC Current Transducers combine a Hall effect sensor and signal conditioner into a single package for use in DC current applications up to 1200 A. The DT Series Large Aperture Transducers have factory set and calibrated ranges, industry standard 4–20 mA, 0–5 VDC or 0–10 VDC outputs, and are available in solid-core DIN rail mount case.



DC Current Transducer Applications

Battery Banks

- Monitor load and charging currents.
- Verify operation.

Transportation

- Measure traction power or auxiliary loads.

Wind and Solar Generated Power

- Measure the current produced or consumed.
- Detect mechanical problems before failure occurs.

Monitor DC Powered Motors

- Monitor current of cranes, saws, sorters and positioning equipment.

DC Current Transducer Features

Factory Set and Calibrated Ranges

- No need for field calibration.
- Eliminates zero and span pots.

Isolation

- Output is magnetically isolated from the input for safety.
- Eliminates insertion losses, no added burden.

Internal Power Regulation

- Works well, even with unregulated power.
- Cuts installation cost.

DIN Rail Mounted Case*

- Makes installation a snap.
- No drilling or screws to lose.
- Optional DIN rail kit available for chassis mounting.*

UL/cUL and CE Approved

- Accepted worldwide.

*For information on the DIN rail accessories kit, see page 147.

Battery Charging System

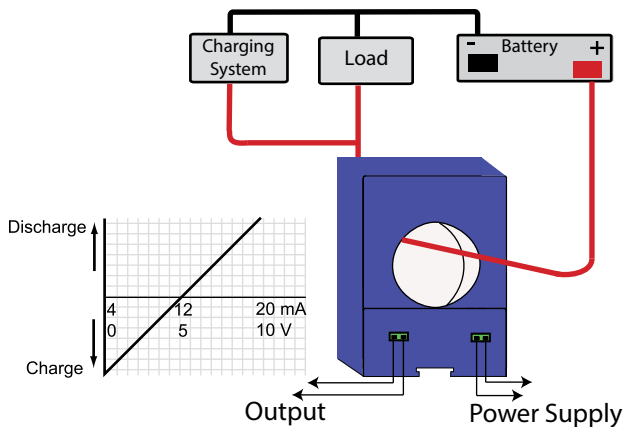

For additional Application Examples, go to www.nktechnologies.com/applications

OEMs

Test & Evaluation Units for OEMs

Free program expedites evaluation process. See page 3 for details.

DC Current Transducer Dimensions

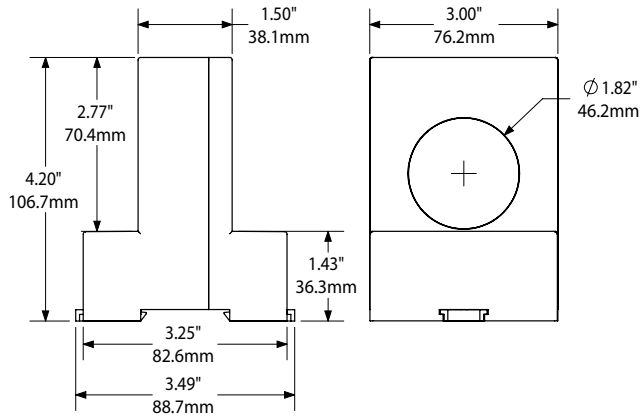

DC Current Transducer Connections

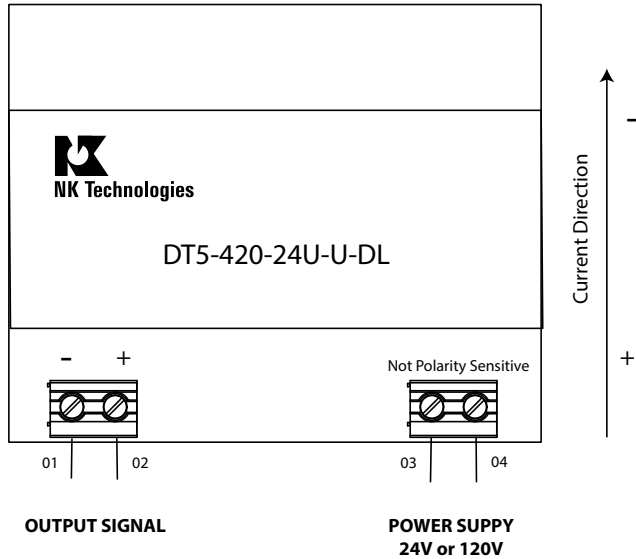

DC Current Transducer Output

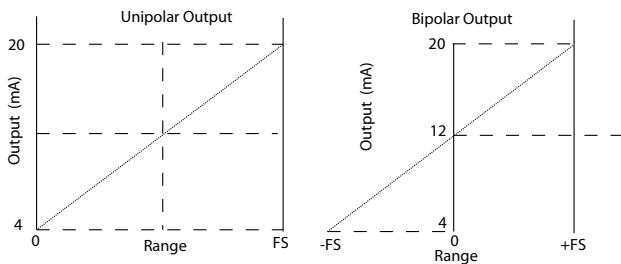

Notes:
 Deadfront captive screw terminals.
 12–22 AWG solid or stranded.
 Observe polarity.
 Unipolar Output: Signal With Current flowing in one direction only.

DC Current Transducer Specifications



| | |
|--------------------------|---|
| Power Supply | • 120 VAC (+/- 10%) • 24 VAC/VDC (+/- 10%) |
| Power Consumption | 2 VA |
| Output Signal | 4–20 mA, 0–5 VDC, 0–10 VDC |
| Output Limit | • 4–20 mA: 23 mA • 0–5 VDC: 5.75 VDC • 0–10 VDC: 11.5 VDC |
| Output Loading | • 4–20 mA: 500 Ω max. • 0–5 VDC: 25 KΩ min. • 0–10 VDC: 50 KΩ min. |
| Accuracy | 2.0% FS |
| Repeatability | 1.0% FS |
| Response Time | 100 ms (to 90% of step change) |
| Input Range | 0–1200 A DC |
| Frequency Range | DC |
| Isolation Voltage | UL listed to 1480 VAC, tested to 3 KV (monitored line to output) |
| Case | UL94 V-0 Flammability Rated |
| Environmental | -4 to 122°F (-20 to 50°C) Surrounding Temperature 0–95% RH, non-condensing |
| Listings | UL/cUL, CE |

DC Current Transducer Ordering Information

Sample Model Number: DT6-420-24U-U-DL
 Solid-core DC current transducer, 0–500 A range, 4–20 mA, 24 VAC/VDC powered, unipolar output.

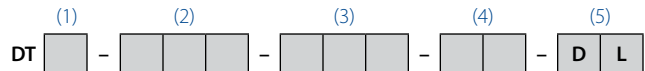

(1) Full Scale Range

| | |
|---|--------|
| 5 | 300 A |
| 6 | 500 A |
| 7 | 750 A |
| 8 | 1000 A |
| 9 | 1200 A |

(3) Power Supply

| | |
|-----|------------|
| 24U | 24 VAC/VDC |
| 120 | 120 VAC |

(2) Output Signal

| | |
|-----|----------|
| 420 | 4–20 mA |
| 005 | 0–5 VDC |
| 010 | 0–10 VDC |

(4) Output Polarity

| | |
|----|----------|
| U | Unipolar |
| BP | Bipolar |

(5) Case Style

| | |
|----|-------------------------------|
| DL | Solid-core, DIN rail mounting |
|----|-------------------------------|



DLT SERIES, 2-WIRE LOOPED POWER DC Current Transducers

DLT Series DC Current Transducers combine a Hall effect sensor and a signal conditioner into a single package. The DLT Series DC Current Transducers are designed to produce an analog 4–20 mA signal proportional to the DC current in the primary conductor. These transducers are available in a solid-core or split-core case design. Lower current ranges make this sensor ideal for use in photovoltaic panel combiner boxes.

DC Current Transducer Applications

DC Current Monitoring

- PV Array combiner boxes.
- Wind generators.
- DC heating applications.
- UPS system monitoring.

Photovoltaic Arrays

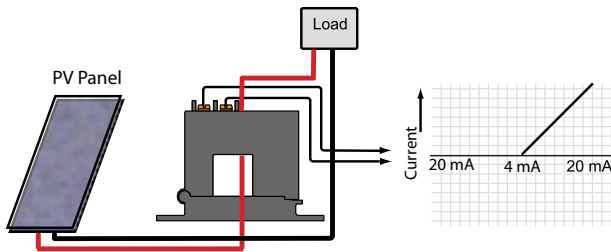

- For additional Application Examples, go to www.nktechnologies.com/applications

Monitoring PV Arrays:

The current produced by a photovoltaic module or array can be easily monitored by using the DLT series current sensors over the conductor exiting the collectors. Using a simple two-wire connection powered by 24 VDC nominal in series with the sensor output, the sensor will produce a signal in real time that is directly proportional to the current being produced by the PV module.

If a single cell fails, or a module quits operating properly, the current output will drop, and the current sensor will reflect the change.

Safer and more stable than shunts, non-contact current sensors are a simple answer to measuring DC current at any point in the PV system.



DC Current Transducer Features

4–20 mA Loop-powered Output

- Industry standard connections, positive indication of correct field wiring.

Single Range

- No chance of field range selection errors.
- Eliminates zero and span pots.

Isolation

- Output is magnetically isolated from the primary circuit for safety.
- Eliminates insertion loss (voltage drop).

UL/cUL and CE Approved

- Accepted worldwide.

DC Current Transducer Output

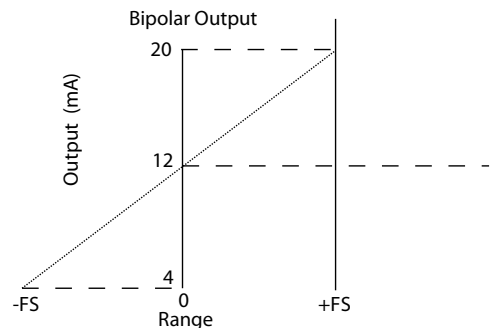
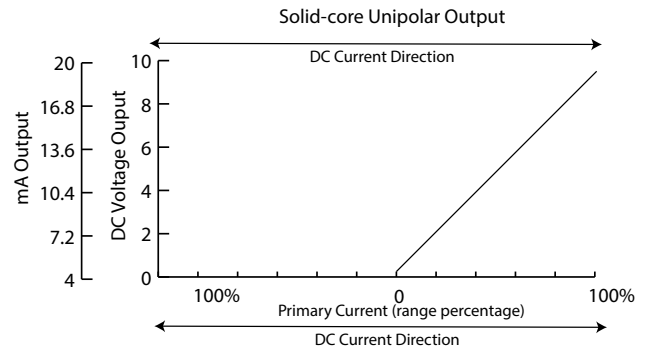

OEMs Test & Evaluation Units for OEMs
Free program expedites evaluation process. See page 3 for details.

DC Current Transducer Dimensions

FF Case

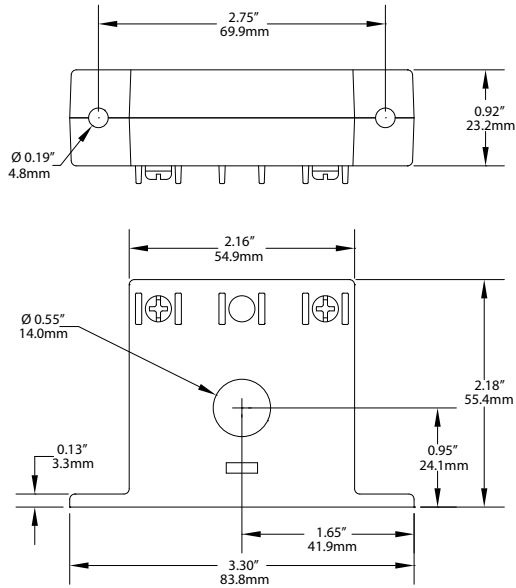

SP Case

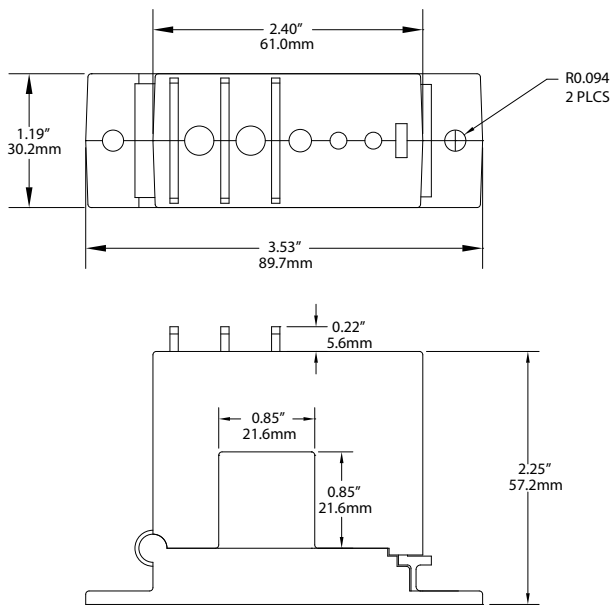

DC Current Transducer Connections

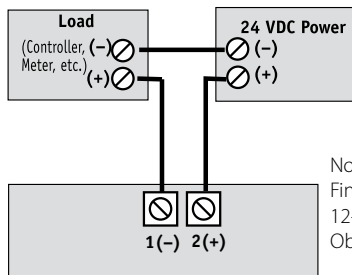

Notes:
Fingersafe captive screw terminals.
12-22 AWG solid or stranded.
Observe polarity.

4-20 mA Output

DC Current Transducer Specifications



| | |
|--------------------------|---|
| Power Supply | 24 VDC (12-40 V) |
| Output Signal | 4-20 mA, loop-powered |
| Output Limit | 23 mA |
| Accuracy | 1.0% FS |
| Response Time | 100 ms (to 90% step change) |
| Range | 0-20 to 0-400 DC, see ordering information |
| Frequency Range | DC |
| Isolation Voltage | UL listed to 1270 VAC, tested to 5 kV |
| Case | UL94 V-0 Flammability Rated |
| Environmental | -4 to 122°F (-20 to 50°C) 0-95% RH, non-condensing |
| Listings | UL/cUL, CE |

DC Current Transducer Ordering Information*

Sample Model Number: DLTB-420-24L-BP-FF
DC current transducer, 50 A range, 4-20 mA output, 24 VDC loop-powered in a solid-core case. (DIN rail adapters are included)

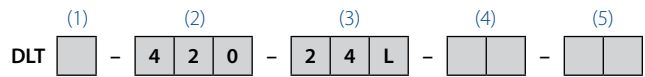

(1) Full Scale Range

| | |
|---|---------|
| A | 0-20 A |
| B | 0-50 A |
| C | 0-100 A |
| D | 0-200 A |
| E | 0-300 A |
| F | 0-400 A |

(2) Output Signal

| | |
|-----|---------|
| 420 | 4-20 mA |
|-----|---------|

(3) Power Supply

| | |
|-----|---------------------|
| 24L | 24 VDC loop-powered |
|-----|---------------------|

(4) Output Polarity

| | |
|----|----------|
| U | Unipolar |
| BP | Bipolar |

(5) Case Style (black only)

| | |
|----|--|
| FF | Solid-core, front terminals (max. range 0-100 A) |
| SP | Split-core (min. range 0-50 A) |

*Bulk packaging only.



Ground Fault Protection

Detecting ground fault conditions and protecting sensitive equipment or personnel from harm are where AG Series sensors can help. A compact design eliminates two-piece solutions while options include factory-set or field-adjustable trip point; N.O. or N.C. latching or auto-reset relays, 24/120/240 V power supply and noise immunity.

Features:

- N.O./N.C. solid-state switch or mechanical relay outputs
- Field-selectable 5 mA, 10 mA or 30 mA set points
- Noise immunity option for EMI/RFI sensitive environments
- UL, CE approved



New! AGV Series Designed for Variable Speed Driven Loads

Ground Fault Relay

Conductors under 0.75" Diameter – Solid Core Case Style

- **AG SERIES** page 93
Contact Trip Point Factory Set between 5 and 950 mA
- **AGV SERIES** page 96
NEW! for Variable Speed Drive Applications
- **DG SERIES** page 109
DC Only- DC Mechanical Relay Output

Conductors under 1.76" Diameter – Solid Core Case Style- Ground Fault Relay

- **AGL SERIES** page 98
Contact Trip Point Factory Set between 5 and 950 mA
- **AGLD SERIES** page 103
Digital Display
Contact Trip Point Field Selectable between 5 and 950 mA

Conductors under 4.0" Diameter – Solid Core Case Style- Ground Fault Relay

- **AG-LC SERIES** page 101
Digital Display
Simple Field Setpoint Adjustment

Analog Ground Fault Measurement

Analog Signal Proportional to Fault Current Conductors under 0.75" Diameter

- **AGT SERIES** page 105
- ### Conductors under 1.76" Diameter
- **AGT-FD SERIES** page 107

Earth Fault Detection Requirements

In North America, most people are familiar with ground fault circuit interrupters (GFCI) since they have been required by the National Electric Code (NEC) since the late 1960's. As the technology became more reliable, ground fault circuit interrupters were required in many more applications. The primary purpose was to reduce the number of deaths caused by electrical shock. Any place where a human body might become the best path to ground is a candidate for ground fault circuit protection. The number of fatalities reduced significantly.

GFCI receptacles and circuit breakers were a huge step forward. With the success in protecting people from shock the interest in ground fault protection increased. A GFCI is designed to disconnect a circuit if current to earth exceeds 6 mA at 120 VAC in locales where the NEC sets the standard for wiring practices. At this low level of fault current it may take a few seconds (UL943A states just under six seconds maximum) before the circuit is de-energized, but if the fault becomes more dangerous, at 20 mA or higher, the circuit is disconnected much faster.

Underwriters Laboratories has established standards under UL943 for personnel protection (avoiding shock to humans) and also for equipment protection at various fault levels and reaction time limits. The point of equipment protection is to keep a fault from damaging the machine more than protecting the operator. Circuits supplying heating loads (heat strips, heat trace and snow melting equipment) are usually not disconnected until the fault current exceeds 30 mA or more. Electric vehicle charging stations have GFCI protection required, but the fault level is somewhere between standard personnel protection and the various levels of equipment protection, and not specified in the NEC.

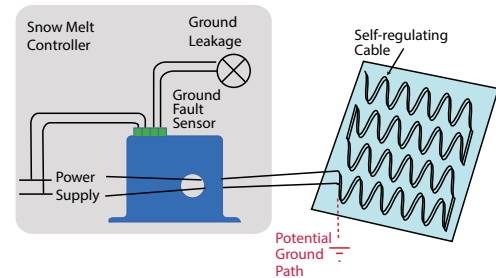

The NEC states the following:

NEC section 427.22. Ground-fault protection of equipment shall be provided for electric heat tracing and heating panels. This requirement shall not apply in industrial establishments where there is alarm indication of ground faults and the following conditions apply: (1) Conditions of maintenance and supervision ensure that only qualified persons service the installed systems. (2) Continued circuit operation is necessary for safe operation of equipment or processes.

NEC section 426.28. Ground-fault protection of equipment shall be provided for fixed outdoor electric deicing and snow-melting equipment.

NEC section 555.3. The overcurrent protective devices that supply the marina, boat yards, and commercial and noncommercial docking facilities shall have ground-fault protection not exceeding 30 mA.

There is no stated fault current limit in section 427.22 for heating equipment or in 426.28 covering snow melt systems, but section 555.3 for protection at docks clearly shows that the monitored circuit must be disconnected from the load if there is a fault over 30 mA.

The NEC calls for ground fault protection for high current supplies too. Sections 215.10 and 230.95 deal with current of 1000 amps and voltages of 480 or higher. Section 517.17 stipulates where fault detection is required in hospitals and other health care facilities.

The importance of protecting an electrical system against faults to earth cannot be overstated. The NEC sections referred to above are just the beginning of equipment protection. This type of fault sensing is not overcurrent detection, so fusing or circuit breakers will keep the conductors or their insulation from being damaged. There are a wide range of applications where ground fault detection is required, but if circuit size is reviewed, most personnel protection is needed for 15 or 20 amp circuits supplied at 120 volts. The requirements for equipment protection vary widely.

NK Technologies offers a ground fault sensor with simple installation and the lowest cost. Rather than combining a detector with a circuit interrupter, the sensor provides contacts to open or close when a fault is detected. The contacts can be used to energize a shunt trip accessory on a circuit breaker, de-energize a contactor coil, or trigger an alarm if the process being monitored should only be stopped in an orderly manner.

OEMs

Test & Evaluation Units for OEMs

Free program expedites evaluation process. See page 3 for details.





Solid-state Outputs



Mechanical Outputs

Available Models

AG Series with Solid-state Outputs offer the benefit of reliable, long-lasting solid-state switches. Solid-state design provides unlimited switch operating life, superior resistance to shock and vibration, zero off-state leakage, high switch speeds and high input-output isolation. Available in solid-core case with screw terminals.

AG Series with Mechanical Outputs are available in solid-core cases with a choice between a N.O. or N.C. SPST latching relay and a SPDT Form C relay with auto-reset. All mechanical models can be ordered with factory-set, field-adjustable setpoint or with a “Tri-set” option, which provides three factory-set setpoints. A noise immunity option is available for applications in harsh EMI/RFI environments.

Output Tables

Normally Energized Models (-FS Option and -ENE Option)

Protection from faults and control power loss.

| | Control Power Applied | | |
|----------------------|-----------------------|----------|--------|
| | No Power | No Fault | Fault |
| N.C. Normally Closed | closed | open | closed |
| N.O. Normally Open | open | closed | open |

Normally De-energized Models (-NF and -DEN Options)

Protection from faults only when power is applied.

| | Control Power Applied | | |
|----------------------|-----------------------|----------|--------|
| | No Power | No Fault | Fault |
| N.C. Normally Closed | closed | closed | open |
| N.O. Normally Open | open | open | closed |

Latching Models (-LA Option) power up initially in the rest (normal) mode. If there is a fault condition or the test button is pushed, the output contacts will change state and latch. The output will remain latched regardless of whether the fault is cleared or control power is removed. To reset the output apply a momentary contact across “reset” terminals.

AG SERIES

Ground Fault (Earth Leakage) Relay

AG Series Ground Fault Detectors help protect people, products, and processes from damage by ground fault conditions by monitoring all current-carrying conductors in grounded single- and three-phase delta or wye systems.



Ground Fault Protection Applications

Personnel Protection (typically 5 mA)

- Detects sensitive ground fault conditions, which may be injurious to personnel and processes.
- Functions as sensor and alarm trigger when part of an overall ground fault protection system.

Equipment Protection (typically 10 mA or 30 mA)

- For applications where personal protection is not the primary concern, higher setpoint capability helps eliminate nuisance tripping while still providing adequate ground fault detection to protect machine electronics.

Regulatory

- Meets requirements as stipulated by governmental and industrial regulatory groups for ground fault sensing.

Ground Fault Protection Features

Broad Range of Options to Match Application Needs

- N.O./N.C. solid-state switch or mechanical relay outputs.
- Normally energized or normally de-energized contacts.
- Noise Immunity option for use in EMI/RFI sensitive environments.

Setpoint Options Maximize Ease-of-Use

- Field-selectable 5 mA, 10 mA or 30 mA setpoints on the AG3 “Tri-set” model makes user adjustments fast, sure and convenient.
- Single factory-calibrated setpoints available from 5 mA to 950 mA.

Compatible with Standard Equipment

- Applicable on single- and three-phase systems.
- Ideal for use with shunt trip breakers.
- Magnetically isolated from monitored circuit and control power.

UR/cUR and CE Approved

- Accepted worldwide.

Insulation Breakdown Monitoring

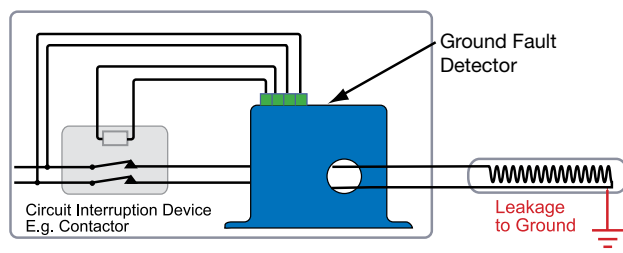

- For additional Application Examples, go to www.nktechnologies.com/applications

“Zero Sum” Operating Principle:

In single- and three-phase AC systems, under normal conditions current flows from the power source to the load and back to the source. As a result, the electromagnetic fields surrounding the conductors cancel, producing a “zero sum current” even when the current in each phase are not equal. As soon as current leaks to ground (fault condition) the current become imbalanced and a net magnetic field results. AG Series detectors monitor this field and trip alarm contacts when the leakage rises above the setpoint.

OEMs **Test & Evaluation Units for OEMs**
Free program expedites evaluation process. See page 3 for details.



Ground Fault Protection Dimensions

Solid-State

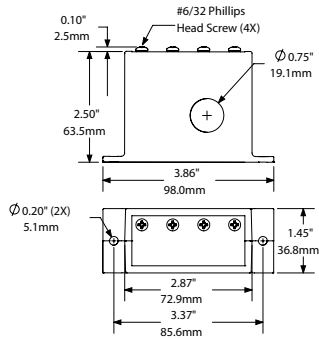

Mechanical

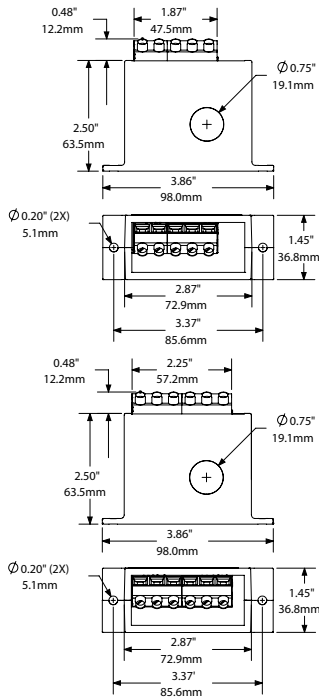

Ground Fault Protection Connections

AG Series
Solid-State Switch

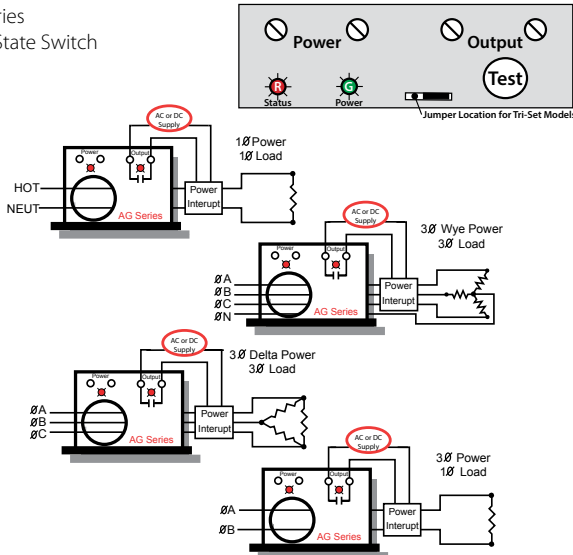

Ground Fault Protection Specifications



| | | |
|--------------------------|---|--|
| Power Supply | <ul style="list-style-type: none"> • 120 VAC (66–132 V) • 24 VAC/VDC (19–29 V) • Green LED = Power On indication | |
| Power Consumption | 2.5 VA max. | |
| Setpoint Range | Factory-calibrated models (specify when ordering): <ul style="list-style-type: none"> • AG1: 5–100 mA (005–100) • AG2: 80–950 mA (080–950) TR3 “Tri-set” models (field jumper select): <ul style="list-style-type: none"> • AG3: 5, 10, or 30 mA | |
| | SOLID-STATE OUTPUT MODELS | MECHANICAL OUTPUT MODELS |
| Output | Isolated solid-state relay | Electromechanical SPDT relay |
| Output Rating | <ul style="list-style-type: none"> • Solid-state AC Switch 1 A @ 240 VAC • Solid-state DC Switch 0.15 A @ 30 VDC | <ul style="list-style-type: none"> • Auto Reset: SPDT Relay 1 A @ 120 VAC, 2 A @ 30 VDC • Latching: SPDT Relay 1 A @ 120 VAC, 2 A @ 30 VDC |
| Off-state Leakage | <ul style="list-style-type: none"> • <10 micro A (N.O.) • <2.5 mA (N.C.) | none |
| Response Time | <ul style="list-style-type: none"> • 150 ms @ 5% above setpoint • 100 ms @ 50% above setpoint • 50 ms @ 500% above setpoint | |
| Time Delay | None | |
| Isolation Voltage | Tested up to 1500 VAC | |
| Frequency Range | 50–60 Hz (monitored circuit) | |
| Noise Immunity | N/A | <ul style="list-style-type: none"> • EMI/RFI shielding • Power supply noise filtering |
| Case | UL94 V-0 Flammability Rated | |
| Environmental | -4 to 122°F (-20 to 50°C) 0–95% RH, non-condensing | |
| Listings | UR/cUR, CE | |

AG Series
Mechanical Relay

Latching Models (-LA)

-NCR1 Output Option Shown, -NOR1 similar

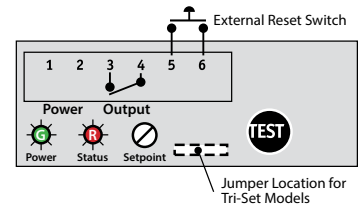

Auto Reset Models

-ENE and -DEN

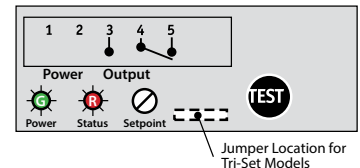

Ground Fault Protection Ordering Information

Solid-state Output Models

Sample Model Number: AG1-NOAC-120-NF-005
 Ground fault detector with normally open solid-state contact output, 120 VAC power supply, 5 mA trip point.

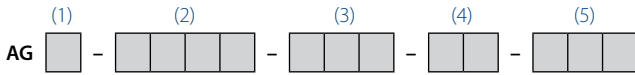

(1) Setpoint Range

| | |
|----|-----------------------|
| 1 | 5–100 mA factory set |
| 2* | 80–950 mA factory set |
| 3 | 5/10/30 mA jumper set |

*Not UL recognized in any configuration.

(2) Output Type

| | |
|------|----------------------------------|
| NOAC | Normally Open, 1 A @ 240 VAC |
| NCAC | Normally Closed, 1 A @ 240 VAC |
| NODC | Normally Open, 0.15 A @ 30 VDC |
| NCDC | Normally Closed, 0.15 A @ 30 VDC |

(3) Power Supply

| | |
|------|---------------------------------------|
| 120 | 120 VAC |
| 24U* | 24 VAC/VDC |
| 240* | 240 VAC (Power consumption is 2.9 VA) |

*Not UL recognized in any configuration.

(4) Options

| | |
|----|-----------------------|
| FS | Normally energized |
| NF | Normally de-energized |

(5) Setpoint

| | |
|------------|------------------------------|
| TR3 | Tri-set |
| 005 to 950 | Factory set trip point in mA |

Ground Fault Relay Output Tables

Normally Energized Models (-ENE Option)

Protection from faults and control power loss.

| | Control Power Applied | | |
|----------------------|-----------------------|----------|--------|
| | No Power | No Fault | Fault |
| N.C. Normally Closed | closed | open | closed |
| N.O. Normally Open | open | closed | open |

Normally De-energized Models (-DEN Options)

Protection from faults only when power is applied.

| | Control Power Applied | | |
|----------------------|-----------------------|----------|--------|
| | No Power | No Fault | Fault |
| N.C. Normally Closed | closed | closed | open |
| N.O. Normally Open | open | open | closed |

Mechanical Output Models

Sample Model Number: AG1-NOR1-120-LA-005
 Ground fault detector with normally open SPST latching relay output, 120 VAC power supply and 5 mA trip point.

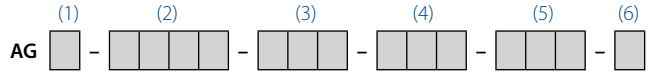

(1) Setpoint Range

| | |
|---|-----------------------|
| 1 | 5–100 mA factory set |
| 2 | 80–950 mA factory set |
| 3 | 5/10/30 mA jumper set |

(2) Output Type

| | |
|------|---|
| NCR1 | Normally Closed SPST Relay Form B (Available only with -LA option) |
| NOR1 | Normally Open SPST Relay Form A (Available only with -LA option) |
| SDT1 | SPDT Relay (Form C) with auto-reset (Available only with -DEN and -ENE options) |

(3) Power Supply

| | |
|-----|------------|
| 120 | 120 VAC |
| 24U | 24 VAC/VDC |

(4) Options

| | |
|-----|--|
| ENE | Normally energized, auto-reset (SDT1 output only) |
| DEN | Normally de-energized, auto-reset (SDT1 output only) |
| LA | Latching (NOR1 and NCR1) |

(5) Setpoint

| | |
|------------|------------------------------|
| TR3 | Tri-set |
| 005 to 950 | Factory set trip point in mA |

(6) Noise Immunity

| | |
|---|----------------|
| N | Noise immunity |
| | None (blank) |

OEMs Test & Evaluation Units for OEMs
 Free program expedites evaluation process. See page 3 for details.



AGV SERIES

Ground Fault (Earth Leakage) Relay Designed for Variable Speed Driven Loads

AGV Series Ground Fault Detectors help protect products and processes from damage due to ground fault conditions by monitoring all current-carrying conductors in grounded single- and three-phase delta or wye systems.

Ground Fault Relay Applications

Process Protection

- Detect sensitive ground fault conditions, which may be injurious to processes.
- Functions as sensor and alarm trigger when part of an overall ground fault protection system.

Equipment Protection

- For applications where equipment protection is desired, a higher setpoint capability and a settable delay from 0-10 seconds helps eliminate nuisance tripping while still providing adequate ground fault detection to protect machine electronics.

Regulatory

- Meets requirements as stipulated by governmental and industrial regulatory groups for ground fault sensing.

Ground Fault Protection When Using A VFD

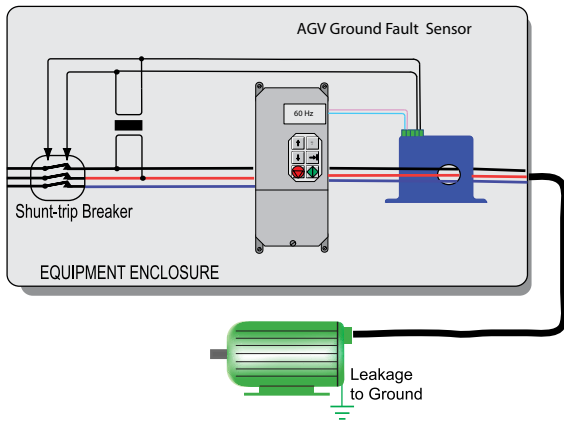

With the growing number of motors driven with a variable frequency drive, detecting low level ground fault current to protect the equipment being used is growing. Whether the motor is driving a submersible pump or a conveyor belt, large faults to earth are all that a drive system alone can detect. Insulation deterioration and moisture ingress produce much smaller currents to earth which are dangerous to personnel and can cause arcing in equipment. Adding an NK Technologies ground fault sensor will help keep the process as safe as possible without the spurious tripping that occurs when other ground fault detection products are used.



Ground Fault Relay Features

Broad Range of Options to Match Application Needs

- N.O./N.C. mechanical relay outputs.
- Normally energized or normally de-energized contacts.
- Latching or automatically resetting outputs available.

Setpoint Options Maximize Ease-of-Use

- Field-selectable 30 mA, 50 mA, or 100 mA setpoints makes user adjustments fast, sure and convenient.

Compatible with Standard Equipment

- Applicable on single- and three-phase systems.
- Ideal for use with shunt trip breakers or contactor coils.
- Electrically isolated from monitored circuit and control power.

UL/cUL

- Accepted worldwide.

“Zero Sum” Operating Principle:

In single- and three-phase AC systems, under normal conditions current flows from the power source to the load and back to the source. As a result, the electromagnetic fields surrounding the conductors cancel, producing a “zero sum current” even when the current in each phase are not equal. As soon as current leaks to ground (fault condition) the current become imbalanced and a net magnetic field results. AGV Series detectors monitor this field and trip alarm contacts when the leakage rises above the setpoint.

Note: Only the current carrying conductors pass through the sensing window, not the grounding bond wire.

Ground Fault Relay Dimensions

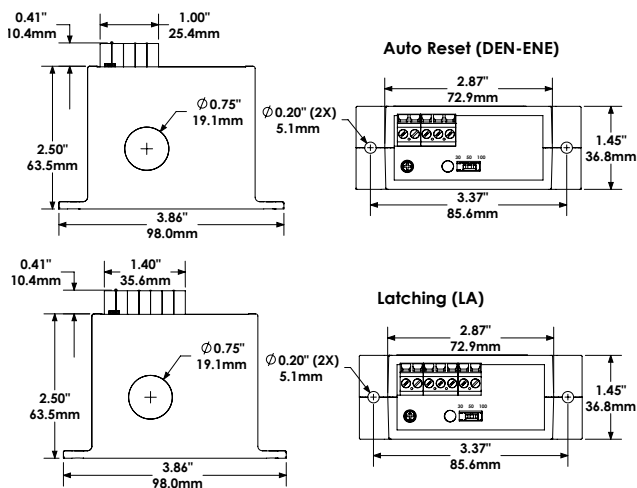

Output Tables

Normally Energized Models (-ENE Option)

Protection from faults and control power loss.

| | Control Power Applied | | |
|----------------------|-----------------------|----------|--------|
| | No Power | No Fault | Fault |
| N.C. Normally Closed | closed | open | closed |
| N.O. Normally Open | open | closed | open |

Normally De-energized Models (-DEN Options)

Protection from faults only when power is applied.

| | Control Power Applied | | |
|----------------------|-----------------------|----------|--------|
| | No Power | No Fault | Fault |
| N.C. Normally Closed | closed | closed | open |
| N.O. Normally Open | open | open | closed |

Latching Models (-LA Option) From factory, power up initially in the reset (normal) mode. If there is a fault condition or the test button is pushed, the output contacts will change state and latch. The output will remain latched regardless of whether the fault is cleared or control power is removed. To reset the output apply a momentary contact across “reset” terminals. Do not apply voltage to reset terminals.

Ground Fault Relay Connections

Auto-Reset Connection

Latching Connection

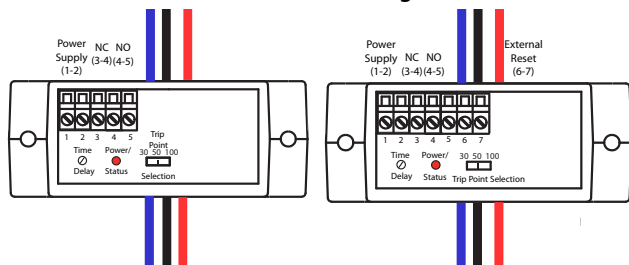

Ground Fault Relay Specifications

| | |
|--------------------------|--|
| Power Supply | • 120 VAC (90–130 V) • 24 VAC/VDC (19–24 V) |
| LED Display | • Green LED: Power untripped • Red LED: Output tripped |
| Power Consumption | 2.4 VA max. 24 V powered 3.0 VA max. 120 V powered |
| Setpoint Range | TR3 “Tri-set” models (field switch select): AGV3: 30, 50, or 100 mA |
| Output Switch | Electromechanical SPDT relay |
| Output Rating | SPDT Relay 1 A @ 125 VAC, 2 A @ 30 VDC resistive |
| Off-state Leakage | None |
| Response Time | • <17 Hz: <140 ms • 17–32 Hz: <75 ms • >32 Hz: <45 ms |
| Time Delay | 0–10 seconds plus response time |
| Isolation Voltage | 1250 VAC, tested to 5 KV |
| Frequency Range | 12–398 Hz (monitored circuit) |
| EMC/Immunity | Power supply and monitored circuit filtering |
| Case | UL94 V-0 Flammability Rated |
| Environmental | -4 to 122°F (-20 to 50°C) 0–95% RH, non-condensing |
| Listings | UL/cUL |

Ground Fault Relay Ordering Information

Sample Model Number: AGV3-SDT-120-LA-TR3
Ground fault detector with SPDT latching relay output, 120 VAC power supply and 30/50/100 mA trip point.

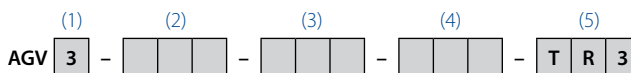

| | | |
|--------------------|-----|-----------------------------------|
| (1) Setpoint Range | 3 | 30/50/100 mA slide switch set |
| (2) Output Type | SDT | SPDT Relay (Form C) |
| (3) Power Supply | 120 | 120 VAC |
| | 24U | 24 VAC/VDC |
| (4) Options | ENE | Normally energized, auto-reset |
| | DEN | Normally de-energized, auto-reset |
| | LA | Latching |
| (5) Setpoint | TR3 | Tri-set 30/50/100 mA |

OEMs

Test & Evaluation Units for OEMs

Free program expedites evaluation process. See page 3 for details.



AGL SERIES

Large Aperture Ground Fault Relay

AGL Series Large Aperture Ground Fault Relays offer one of the largest aperture diameters in the industry while maintaining a compact overall profile. Intended for sensing earth leakage, the AGL Series offers a choice of N.O. or N.C. latching relays or an SPDT Form C relay with auto-reset. Case features integral DIN rail mounting as standard and optional noise immunity coatings for applications in harsh EMI/RFI environments.



Ground Fault Relay Applications

- Replace bulky two-piece sensor solutions which require separate CTs or relay modules.
- Use with shunt trip breakers to provide total ground fault protection to sensitive machine electronics.
- Detect ground faults in resistance/impedance heating, industrial automation and control, theatrical lighting, portable power distribution, and snow melt/heat trace applications.
- Sense progressive levels of ground fault in motors or heating systems to detect deterioration prior to catastrophic failure.

Moisture Ingress on a Submersible Pump Motor

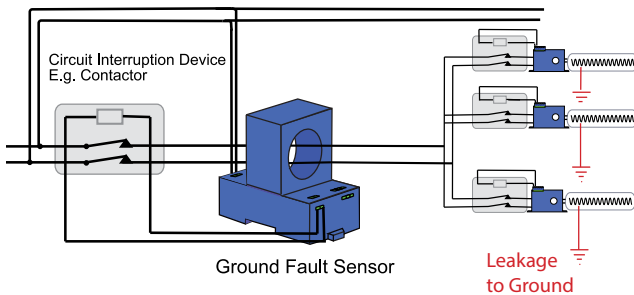

Ground Fault Relay Features

Setpoint Options Maximize Ease-of-Use

- Setpoint options include factory-adjustable setpoint from 5 mA –950 mA or “TR3 Tri-Set” models with field-selectable 5/10/30 mA settings.
- Finger-safe terminals for worry-free installation and operation.
- Aperture orientation is perpendicular to DIN rail, allowing for clean and efficient wiring and minimizing space between multiple components.
- Choice of dependable latching SPST or auto-reset SPDT (form C) electromechanical relay outputs.
- Uses “Zero Sum” operating principle to reliably sense imbalance in magnetic fields associated with current leakage to ground.
- Typical response times from 50 ms to 150 ms.
- Integral “push-to-test” button with LED indication of contact status.

DIN Rail Mount*

- Integral DIN rail mount with spring loaded mounting clips.

UL/cUL and CE Approved.

- Accepted worldwide.

*For information on the DIN rail accessories kit, see page 147.

• For additional Application Examples, go to www.nktechnologies.com/applications

Ground Fault Relay Dimensions

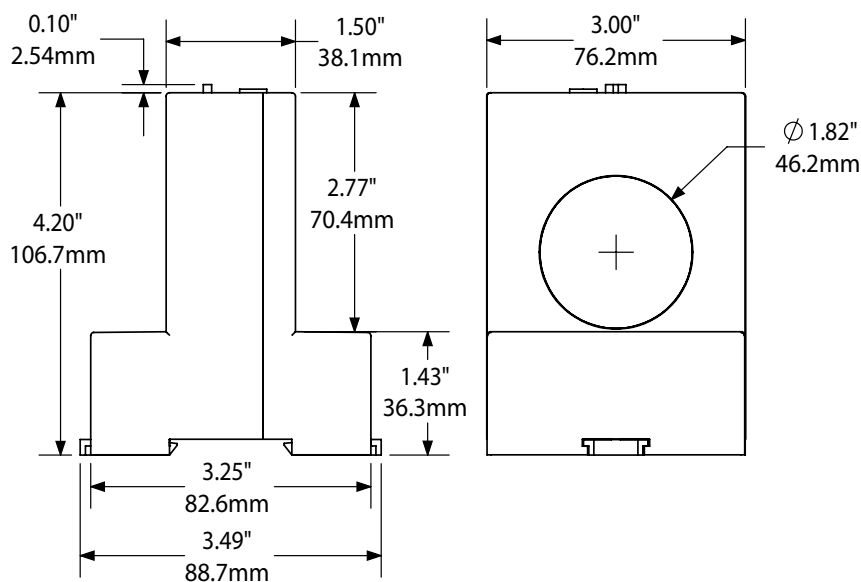

Ground Fault Relay Connections

Auto-Reset

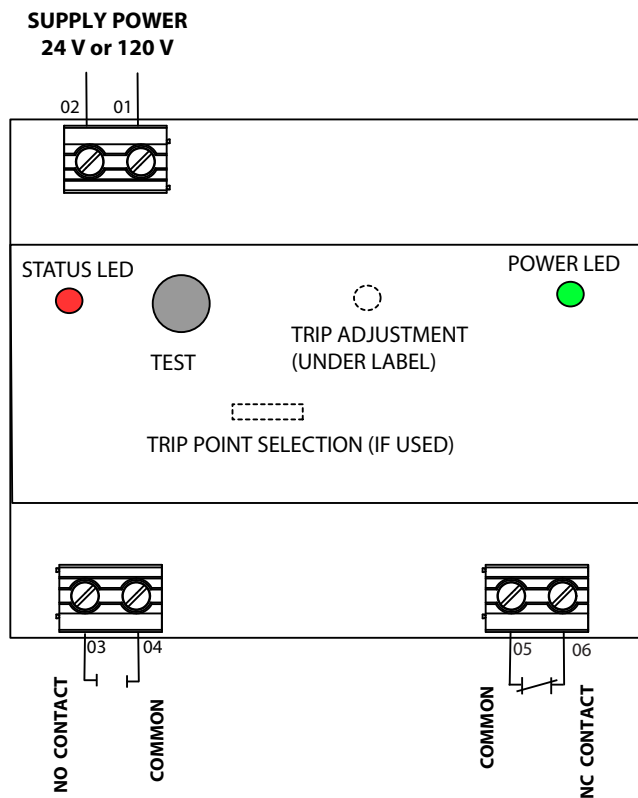

Latching

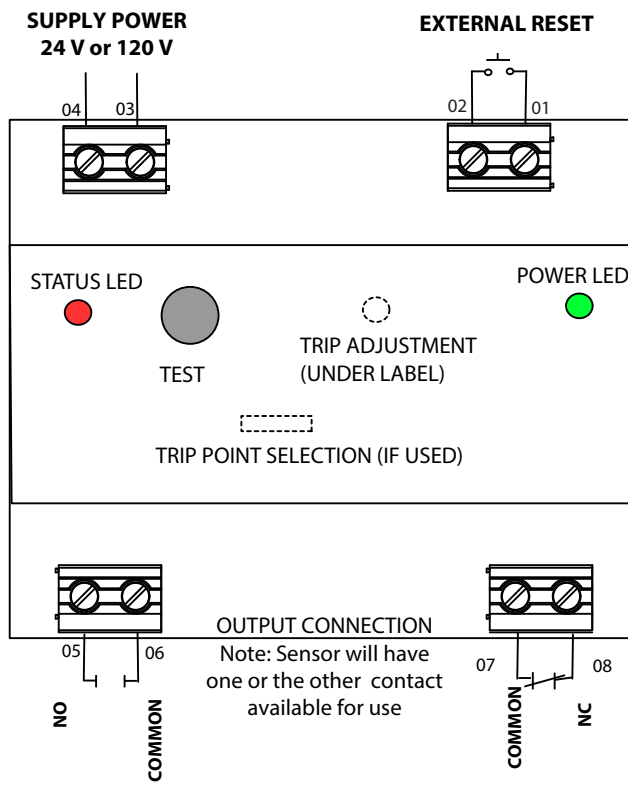

OEMs

Test & Evaluation Units for OEMs

Free program expedites evaluation process. See page 3 for details.



Ground Fault Relay Specifications



| | |
|--------------------------|--|
| Power Supply | <ul style="list-style-type: none"> • 120 VAC (66–132 V) • 24 VAC/VDC (19–29 V) |
| Power Consumption | 2.5 VA |
| Setpoint Range | Factory-calibrated models (specify when ordering): <ul style="list-style-type: none"> • AGL1: 5–100 mA (005–100) • AGL2: 80–950 mA (080–950) TR3 “Tri-set” models (field jumper select): <ul style="list-style-type: none"> • AGL3: 5, 10, or 30 mA |
| Output Switch | Electromechanical SPDT relay |
| Output Rating | 1 A @ 120 VAC, 2 A @ 30 VDC |
| LED Display | <ul style="list-style-type: none"> • Green LED = Power On indication • Red LED = Tripped Output Relay indication |
| Response Time | <ul style="list-style-type: none"> • 150 ms @ 5% over setpoint • 100 ms @ 50% over setpoint • 50 ms @ 500% over setpoint |
| Time Delay | None |
| Noise Immunity | <ul style="list-style-type: none"> • EMI/RFI Shielding • Power supply noise filtering |
| Isolation Voltage | Tested to 1.5 KV |
| Frequency Range | 50–60 Hz (monitored circuit) |
| Case | UL94 V-0 Flammability Rated |
| Environmental | -4 to 122°F (-20 to 50°C) 0–95% RH, non-condensing |
| Listings | UL/cUL, CE |

Ground Fault Relay Ordering Information

Sample Model Number: AGL1-NOR1-120-LA-005

Ground fault relay with normally open SPST latching relay output, 120 VAC power supply and 5 mA trip point.

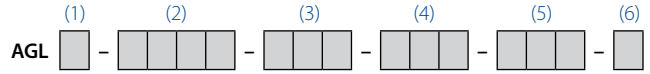

(1) Setpoint Range

| | |
|---|-----------------------|
| 1 | 5–100 mA factory set |
| 2 | 80–950 mA factory set |
| 3 | 5/10/30 mA jumper set |

(2) Output Type

| | |
|------|---|
| NCR1 | Normally Closed SPST Relay Form B (Available only with -LA option) |
| NOR1 | Normally Open SPST Relay Form A (Available only with -LA option) |
| SDT1 | SPDT Relay (Form C) with auto-reset (Available only with -DEN and -ENE options) |

(3) Power Supply

| | |
|-----|------------|
| 120 | 120 VAC |
| 24U | 24 VAC/VDC |

(4) Options

| | |
|-----|--|
| ENE | Normally energized, auto-reset (SDT1 output only) |
| DEN | Normally de-energized, auto-reset (SDT1 output only) |
| LA | Latching (NOR1 and NCR1) |

(5) Setpoint

| | |
|------------|---|
| TR3 | (Tri-set AGL3 only) |
| 005 to 950 | Factory set trip point in mA (AGL1 and AGL2 only) |

(6) Noise Immunity

| | |
|---|----------------|
| N | Noise immunity |
| | None (blank) |

Ground Fault Relay Output Tables

Normally Energized Models (-ENE Option)

Protection from faults and control power loss.

| | Control Power Applied | | |
|----------------------|-----------------------|----------|--------|
| | No Power | No Fault | Fault |
| N.C. Normally Closed | closed | open | closed |
| N.O. Normally Open | open | closed | open |

Normally De-energized Models (-DEN Options)

Protection from faults only when power is applied.

| | Control Power Applied | | |
|----------------------|-----------------------|----------|--------|
| | No Power | No Fault | Fault |
| N.C. Normally Closed | closed | closed | open |
| N.O. Normally Open | open | open | closed |

AG-LC SERIES

Ground Fault Sensor - Large Solid-Core

AG-LC series ground fault sensors are the latest design innovation from NK Technologies. The 2011 NEC added section 555.3 to require ground fault protection of the main overcurrent device feeding marinas and boat yards. These services are often carrying up to 800 amps; most sensor designs will not allow the conductors to pass through a single sensing ring. By designing a sensor in a large solid-core housing, the conductors will not have to be passed through a separate sensing device like a zero sequence current transformer. This design makes monitoring of larger circuits a breeze, whether to protect boaters or large equipment like amusement park rides or gantry cranes.

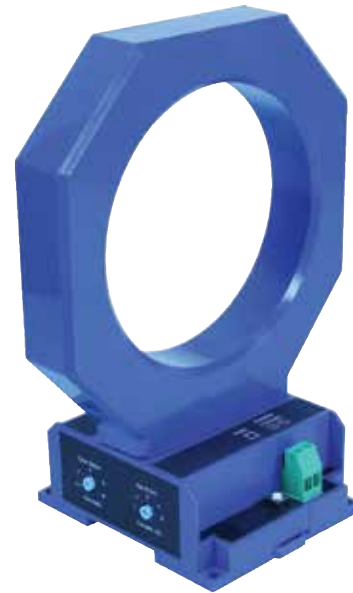

Ground Fault Sensor Applications

Monitor Large Machines

- Detect leakage to earth before the problem can cause damage.

Water Delivery and Treatment

- Keep pumping systems safe and in operation.
- Sense faulting stator windings prior to failure.

Generators

- Shut down equipment when leakage current exceeds hazardous levels.

Sense Current to Earth in Marinas

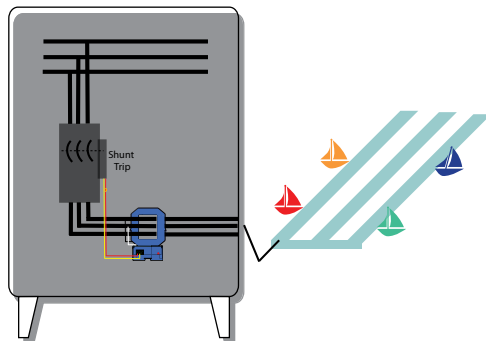

Equipment on board a vessel can pass current to earth through water, causing a dangerous condition to swimmers and boaters in fresh water marinas and boat docking facilities. Use a ground fault sensor with a shunt trip breaker to shut off the power when excessive current flows to earth.

Ground Fault Sensor Features

Electromechanical Relay Output

- Provides both normally open and normally closed contacts.
- Compatible with most automation and control systems.

Externally Powered

- A choice of fail safe or standard operation.

Simple Field Setpoint Adjustment

- Single turn potentiometer with setpoint shown on label.
- Adjustable delay to mask out nuisance fault current.

Large Solid-Core Case

- Large sensing window provides ample space for multiple conductors.

DIN Rail Mount*

- Simple snap onto DIN rail or attach with screws to a panel for secure mounting.

UL/cUL Approved

- Accepted worldwide.
- Conformally coated circuit boards standard.

*For information on the DIN rail accessories kit, see page 147.

Output Contact Action

| Contact Action | No Power Applied | Power Applied | Fault Detected |
|--------------------|------------------|---------------|----------------|
| DEN (Powered) | NO = Open | NO = Open | NO = Closed |
| | NC = Closed | NC = Closed | NC = Open |
| ENE (Fail Safe) | NO = Open | NO = Closed | NO = Open |
| | NC = Closed | NC = Open | NC = Closed |
| LA (Powered) | NO = Open | NO = Open | NO = Closed |
| | NC = Closed | NC = Closed | NC = Open |
| ELA (Fail Safe) | NO = Open | NO = Closed | NO = Open |
| | NC = Closed | NC = Open | NC = Closed |

OEMs **Test & Evaluation Units for OEMs**
Free program expedites evaluation process. See page 3 for details.



AG-LC SERIES

490084008 Rev 2

Ground Fault Sensor Dimensions

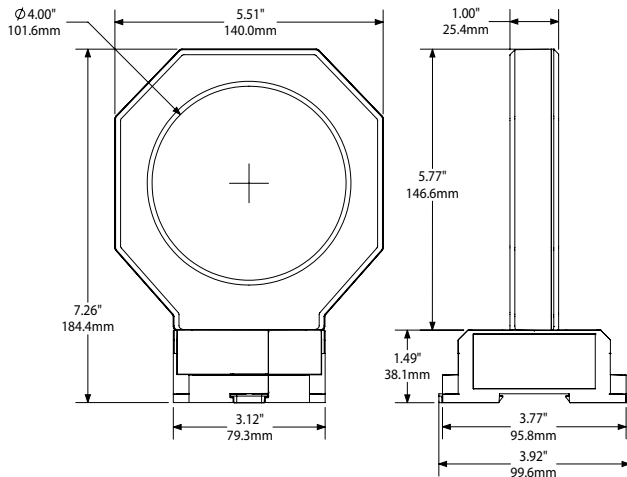

Ground Fault Sensor Connections

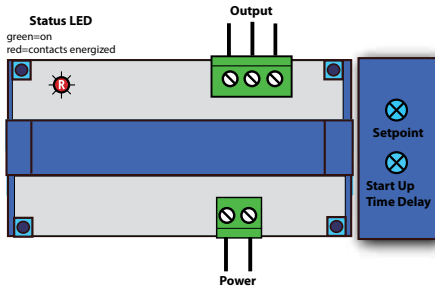

Ground Fault Sensor Ordering Information

Sample Model Number: AG3-SDT-24U-DEN-LC
 AC ground fault sensor, 300–1500 mA, SPDT relay output, 24 VAC/VDC powered, normally de-energized, solid-core case, DIN rail or panel mount.

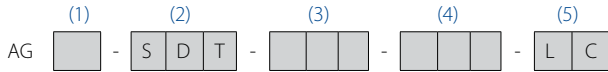

(1) Range - Field Adjustable

| | |
|---|-------------|
| 1 | 30–150 mA |
| 2 | 80–400 mA |
| 3 | 300–1500 mA |
| 4 | 1.0–5.0 A |

(2) Output Type

| | |
|-----|---------------------------------|
| SDT | Single pole, double throw relay |
|-----|---------------------------------|

(3) Power Supply

| | |
|-----|------------|
| 24U | 24 VAC/VDC |
| 120 | 120 VAC |

(4) Contact Action

| | |
|-----|--------------------------------|
| DEN | Normally de-energized |
| ENE | Normally energized |
| LA | Latching normally de-energized |
| ELA | Latching normally energized |

(5) Case

| | |
|----|--|
| LC | Large solid-core, panel or DIN Rail mounting |
|----|--|

Ground Fault Sensor Specifications



| | | | | | | | | | |
|--------------------------------|---|---|-----------|---|-----------|---|-------------|---|-----------|
| Power Supply | 120 VAC (108-132 V) or 24 VAC/VDC (22-28 V) | | | | | | | | |
| Power Consumption | <4 VA | | | | | | | | |
| Output Rating | Electromechanical relay 1 A @ 120 VAC, 2 A @ 30 VDC resistive | | | | | | | | |
| Indicating Bi-color LED | <ul style="list-style-type: none"> • Green: Power on, fault current below setpoint • Orange: Power on, fault current over setpoint • Off: Power off | | | | | | | | |
| Response Time | 100 ms (current 90% over setpoint) | | | | | | | | |
| Output Operation | Normally de-energized, energized or latching | | | | | | | | |
| Manual Buttons | Test: Test to simulate a fault (hold longer than time delay settings) Reset: Press to unlatch (or add an external button) | | | | | | | | |
| Trip Delay | 0.1 to 8 seconds | | | | | | | | |
| Setpoint Range | <table border="1"> <tr> <td>1</td> <td>30–150 mA</td> </tr> <tr> <td>2</td> <td>80–400 mA</td> </tr> <tr> <td>3</td> <td>300–1500 mA</td> </tr> <tr> <td>4</td> <td>1.0–5.0 A</td> </tr> </table> | 1 | 30–150 mA | 2 | 80–400 mA | 3 | 300–1500 mA | 4 | 1.0–5.0 A |
| 1 | 30–150 mA | | | | | | | | |
| 2 | 80–400 mA | | | | | | | | |
| 3 | 300–1500 mA | | | | | | | | |
| 4 | 1.0–5.0 A | | | | | | | | |
| Isolation Voltage | UL Listed to 2200 VAC | | | | | | | | |
| Frequency Range | 40–60 Hz | | | | | | | | |
| Environmental | -4 to 122°F (-20 to 50°C) 0–95% RH, non-condensing | | | | | | | | |
| Listings | UL/cUL | | | | | | | | |

Sample Model Number-Factory Set: AGC-SDT-24U-DEN-100-LC
 AC ground fault sensor, 100 mA factory set, SPDT relay output, 24 VAC/VDC powered, normally de-energized, solid-core case, DIN rail or panel mount.



(1) Model

| | |
|---|-----------------------|
| C | 30–150 mA Factory Set |
| D | 80-400 mA Factory Set |

(2) Output Type

| | |
|-----|---------------------------------|
| SDT | Single pole, double throw relay |
|-----|---------------------------------|

(3) Power Supply

| | |
|-----|------------|
| 24U | 24 VAC/VDC |
| 120 | 120 VAC |

(4) Contact Action

| | |
|-----|--|
| DEN | Normally de-energized (Only works with sensor powered) |
| ENE | Normally energized (Loss of sensor power causes output change - Fail safe operation) |
| LA | Latching normally de-energized |
| ELA | Latching normally energized (Fail safe operation) |

(5) Trip Point

| | |
|-----|---------------------|
| XXX | 030–400 (30–400 mA) |
|-----|---------------------|

(6) Case

| | |
|----|--|
| LC | Large solid-core, panel or DIN Rail mounting |
|----|--|

AGLD SERIES

Ground Fault Sensor with Digital Display

AGLD Series Ground Fault Sensors keep machinery and their operators safe from accidental shocks. The large, one piece solid-core design allows for installation over wires feeding heavy loads. The output relay will change state at any point between 5 and 100 mA, or 80 and 950 mA. A delay can be set to allow down stream protection to activate before this sensor, keeping the main circuit protection hot and the equipment energized while the smaller faults are cleared. The large LED display shows the precise trip point and the extra delay clearly, in any light condition. The display flashes when there is current sensed over the trip point.



Ground Fault Sensor Applications

Monitor Large Machines

- Detect fault currents before damage can occur. Connect the output to a shunt trip breaker operating solenoid or to the circuit powering a connector coil.

Water Delivery and Treatment

- Detect moisture ingress in submersible pumps.

Heating Processes

- If an element shorts to ground, the sensor will activate to de-energize the circuit, keeping safety at the forefront.

Insulation Breakdown

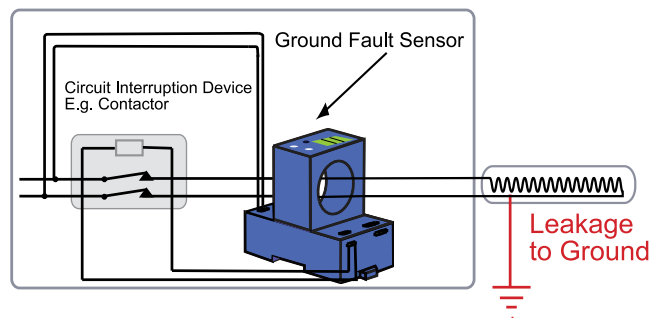

Ground Fault Sensor Features

Electromechanical Relay Output

- Provides both normally open and normally closed contacts.
- Compatible with most automation and control systems.

Externally Powered

- A choice of fail safe or standard operation.

Simple Field Setpoint Adjustment

- Single turn potentiometer with setpoint shown on display.
- Adjustable delay shown when knob is turned.

Large Solid-core Case

- Large sensing window provides ample space for multiple conductors.

DIN Rail Mount*

- Simple snap onto DIN rail.

UL/cUL Approved, CE

- Accepted worldwide.

*For information on the DIN rail accessories kit, see page 147.

OEMs

Test & Evaluation Units for OEMs

Free program expedites evaluation process. See page 3 for details.



AGLD SERIES

490060017 Rev 3

Ground Fault Sensor Dimensions

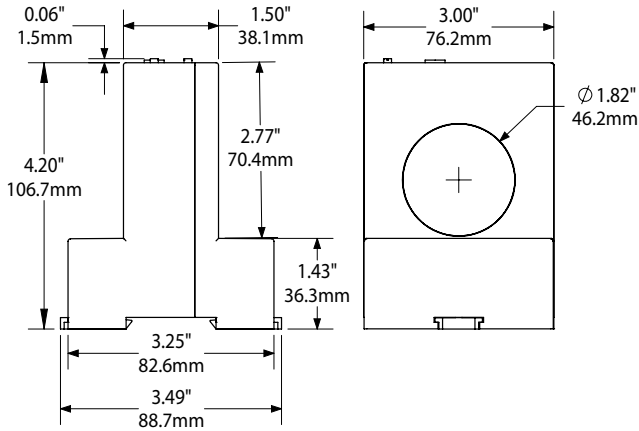

Ground Fault Sensor Specifications



| | |
|--------------------------|---|
| Power Supply | • 24 VAC/VDC (20-30 V) |
| Power Consumption | <4 VA |
| Setpoint Range | AGLD1: 5–100 mA AGLD2: 80–950 mA |
| Output Switch | Electromechanical SPDT relay |
| Output Rating | 1 A @ 120 VAC, 2 A @ 30 VDC max. |
| LED Display | • Displays trip point in mA • Displays delay period when adjusted (ms X10) • Off: Power off |
| Response Time | 120 ms |
| Output Operation | Normally energized or normally de-energized |
| Time Delay | 1 second (adjustable after startup) |
| Isolation Voltage | UL listed to 1240 VAC |
| Frequency Range | 50–60 Hz (monitored circuit) |
| Case | UL94 V-0 Flammability Rated |
| Environmental | -4 to 104°F (-20 to 40°C) Surrounding Air 0–95% RH, non-condensing |
| Listings | UL/cUL, CE |

Ground Fault Protection

Ground Fault Sensor Connections

Auto Reset

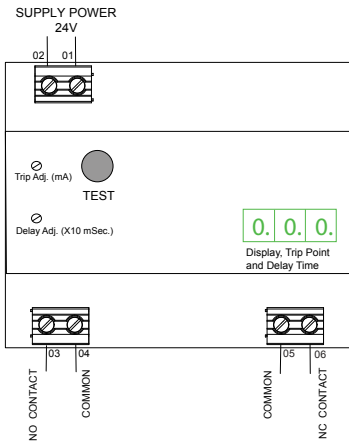

Latching

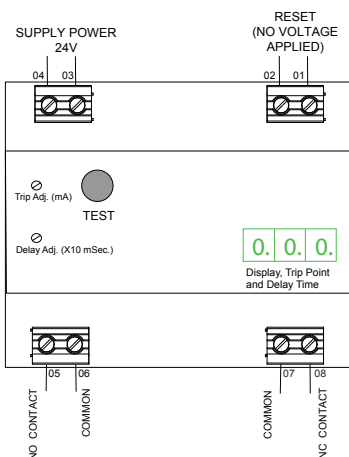

Ground Fault Sensor Ordering Information

Sample Model Number: AGLD1-SDT1-24U-ENE-ADJ

AC ground fault sensor, 5–100 mA range, SPDT switch output, 24 VAC/VDC powered, normally energized relay, large case, DIN rail mounting.

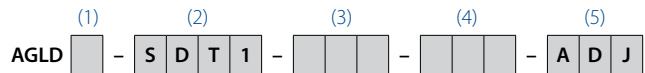

(1) Model

| | |
|---|-----------|
| 1 | 5–100 mA |
| 2 | 80–950 mA |

(2) Output Type

| | |
|------|---------------------------------|
| SDT1 | Single pole, double throw relay |
|------|---------------------------------|

(3) Power Supply

| | |
|-----|------------|
| 24U | 24 VAC/VDC |
|-----|------------|

(4) Contact Action

| | |
|-----|-----------------------|
| DEN | Normally de-energized |
| ENE | Normally energized |
| LA | Latching output |

(5) Setpoint

| | |
|-----|---------------------|
| ADJ | Adjustable setpoint |
|-----|---------------------|

AGT SERIES

Ground Fault Measurement

AGT Series Ground Fault Transducers combine a current transformer and a True RMS signal conditioner into a single package. The AGT Series is designed to produce an analog 4–20 mA signal proportional to earth or ground fault current, or any low consumption AC load. Available in a solid-core case. When connected to a controller or data logger, NEC requirements for alarm can be met.



Ground Fault Transducer Applications

Current Leakage Detection

- Monitor heating or other loads to detect increasing leakage current.
- Pass all current carrying conductors through aperture to sense zero-sum current.

Very Light Loads

- Accurate measurement of very small but critical loads.
- Current measurement gives faster response than temperature measurement.

Ground Fault Currents

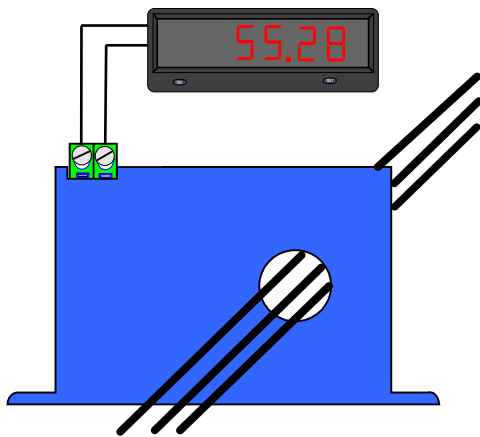

- For additional Application Examples, go to www.nktechnologies.com/applications

Ground Fault Transducer Features

True RMS Output

- True RMS technology is accurate on distorted waveforms like VFD or SCR outputs.

Single Range

- No chance of field range selection errors.
- Eliminates zero and span pots.

Isolation

- Output is magnetically isolated from the input for safety.
- Eliminates insertion loss (voltage drop).

UL/cUL Approved

- Accepted worldwide.

Selecting the right ground fault detector:

NEC Article 427-22 requires that fault currents be monitored on industrial equipment. However, where maintenance and supervision ensure that only qualified persons will service the equipment and continued circuit operation is necessary for safe operation and processes, alarm indication is also required. A fault current transducer can send a signal to a panel meter with alarm contacts or a controller. As an example, the alarm points can be configured so one alarm is initiated when fault current reaches 30 mA, and another when it rises above 70 mA. Ground fault protection is required in many applications, and NK Technologies has a sensor that can be coupled with your control system to provide this needed alarm or circuit disconnection.

OEMs

Test & Evaluation Units for OEMs

Free program expedites evaluation process. See page 3 for details.



AGT SERIES

292080304 Rev 1

Ground Fault Transducer Dimensions

FL Case

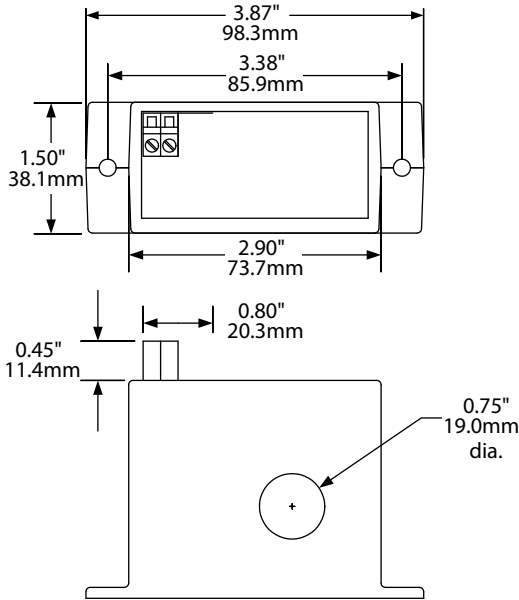

Ground Fault Protection

Ground Fault Transducer Connections

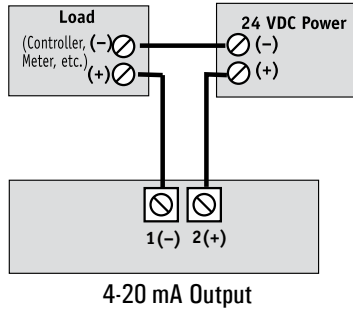

Notes:
 Finger safe captive screw terminals.
 12–22 AWG solid or stranded.
 Observe polarity.

Ground Fault Transducer Specifications



| | |
|--------------------------|---|
| Power Supply | 24 VDC loop-powered (12–40 V) |
| Power Consumption | <2 VA |
| Output | 4–20 mA, loop-powered, True RMS |
| Output Limit | 23 mA |
| Response Time | 600 ms (to 90% step change) |
| Input Range | Single range of 0–50 or 0–100 mA; custom ranges available; consult factory. |
| Isolation Voltage | UL listed to 1270 VAC, tested to 5 KV |
| Frequency Range | 40–400 Hz |
| Case | UL94 V-0 Flammability Rated |
| Environmental | -4 to 122°F (-20 to 50°C) 0–95% RH, non-condensing |
| Listings | UL/cUL |

Ground Fault Transducer Ordering Information

Sample Model Number: AGT2-420-24L-FL

True RMS AC ground fault transducers, 100 mA ranges, 4–20 mA output, 24 VDC loop-powered in a solid-core case.



(1) Full Scale Range

| | |
|---|----------|
| 1 | 0–50 mA |
| 2 | 0–100 mA |

(2) Output Signal

| | |
|-----|---------|
| 420 | 4–20 mA |
|-----|---------|

(3) Power Supply

| | |
|-----|---|
| 24L | 24 VDC loop-powered (4–20 mA output ONLY) |
|-----|---|

(4) Case Style

| | |
|----|--------------------------|
| FL | Solid-core, top terminal |
|----|--------------------------|

AGT-FD SERIES

Ground Fault Measurement

AGT-FD Series Ground Fault sensors detect faults to earth from 0 mA to 100 mA and produce an output signal of 0–10 VDC in proportion to the amount of current passing to ground. The output is equal to the RMS value of the earth leakage. The AGT-FD can also be used to measure and monitor any low value AC circuit current by passing just one of the conductors through the sensing window.



Ground Fault Transducers Applications

Current Leakage

- Monitor residual (earth leakage) current by passing all of the current carrying conductors through the sensing aperture.

Very Light Loads

- Monitor circuits of varying frequencies or distorted wave shapes, but very low current usage.

Display Shows Amount of Fault Current Present

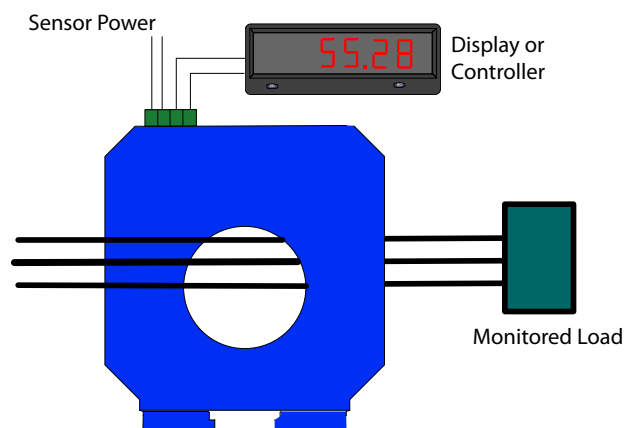

Ground Fault Transducers Features

Analog Output Signal

- 0–5 or 0–10 VDC proportional to 0–100 mA.
- Sensing window large enough to monitor 100 amp circuits.

Externally Powered

- Low power consumption (< 2 VA).
- 24 Volt AC or DC (20–30 V).

Factory Calibrated

- Warranted to stay accurate for five years minimum.
- Compatible with most PLCs, panel meters and other controllers.

Large Solid-core Case

- Large sensing window provides ample space for multiple conductors.

DIN Rail* or Panel Mount

- Simple snap onto DIN rail.

UL, cUL and CE Approved

- Accepted worldwide.

*For information on the DIN rail accessories kit, see page 147.

OEMs

Test & Evaluation Units for OEMs

Free program expedites evaluation process. See page 3 for details.



AGT-FD SERIES

292000118 Rev 1

Ground Fault Sensor Dimensions

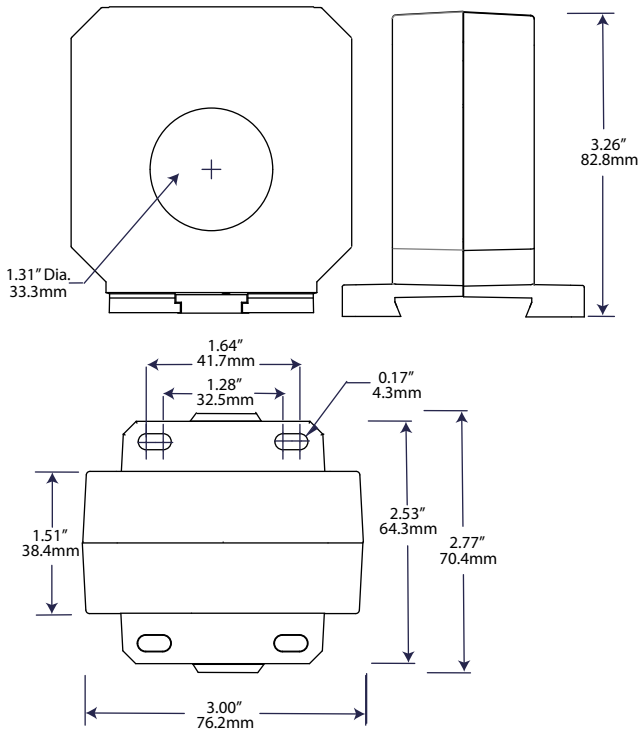

Ground Fault Protection

Ground Fault Sensor Connections

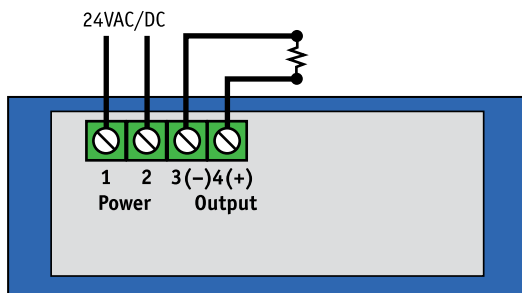

Ground Fault Sensor Specifications



| | |
|--------------------------|---|
| Power Supply | 24 VAC or DC (20–30 V) |
| Power Consumption | <2 VA |
| Output | 0–5 VDC or 0–10 VDC |
| Input Range | 0–100 mA |
| Response Time | 250 ms (to 90% step change) |
| Isolation Voltage | UL listed to 1270 VAC, tested to 5 KV |
| Frequency Range | 50–400 Hz |
| Case | UL94 V-0 Flammability Rated |
| Environmental | -4 to 122°F (-20 to 50°C) 0–95% RH, non-condensing |
| Listings | UL, cUL, CE |

Ground Fault Sensor Ordering Information

Sample Model Number: AGT2-010-24U-FD
Ground fault sensor, output 0–10 VDC proportional to AC current, 24 VAC/DC powered, DIN rail or panel mounted.

AGT (1) 2 - (2) - (3) 2 4 U - (4) F D

(1) Model

| | |
|---|----------|
| 2 | 0–100 mA |
|---|----------|

(2) Output Type

| | |
|-----|-------------------------------------|
| 005 | 0–5 VDC proportional to AC current |
| 010 | 0–10 VDC proportional to AC current |

(3) Power Supply

| | |
|-----|--------------|
| 24U | 24 VAC or DC |
|-----|--------------|

(4) Case

| | |
|----|--|
| FD | Solid-core, DIN rail or panel mounting |
|----|--|

DG SERIES

DC Ground Fault Relay

DG Series Ground Fault Relays keep machinery and their operators safe from accidental shocks. The one-piece, solid-core design allows for installation over wires feeding loads to about fifty amps. The output relay will change state at factory setpoint between 5 and 50 mA of DC current to earth.



Ground Fault Protection

Ground Fault Relay Applications

Monitor Photovoltaic Panels

- Detect fault currents before damage can occur. Connect the output to a shunt trip breaker operating solenoid or to the circuit powering a contactor coil.

Water Delivery and Treatment

- Detect moisture ingress in submersible pumps .

Heating Processes

- If an element shorts to ground, the sensor will activate to de-energize the circuit, keeping safety at the forefront.

Communications Towers

- Notification if a battery powered supply is allowing current to earth.

Ground Fault Relay Features

Electromechanical Relay Output

- Auto reset models have both normally open and normally closed contacts.
- Latching models have one normally open and one normally closed contact.
- Compatible with most automation and control systems.

Externally Powered

- A choice of fail safe or standard auto reset operation, or latching contact.

Solid-core Case

- Sensing window provides ample space for multiple conductors.

Designed for UL, CUL and CE Approval

- Accepted worldwide.

DC Fault Current Sensing

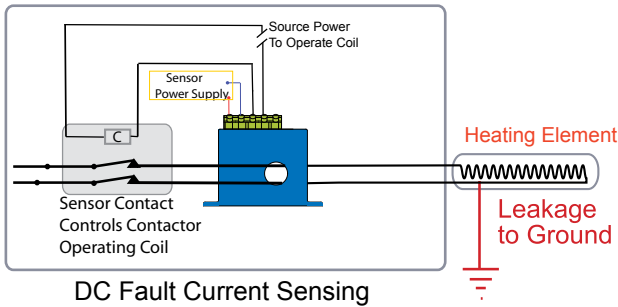

Contact Action Table

| | No Power | | Powered | | Fault Detected | |
|-----|----------|--------|---------|--------|----------------|--------|
| | NO | NC | NO | NC | NO | NC |
| DEN | open | closed | open | closed | closed | open |
| ENE | open | closed | closed | open | open | closed |
| LA | open | closed | open | closed | closed | open |

LED ACTION TABLE

| | Power | | Status | | Power | | Status | |
|-----|-------|--------|--------|--------|-------|--------|--------|--------|
| | Power | Status | Power | Status | Power | Status | Power | Status |
| DEN | Off | Off | On | Off | On | On | On | On |
| ENE | Off | Off | On | On | On | On | On | Off |
| LA | Off | Off | On | Off | On | On | On | On |

Note that the Power LED indicates that the sensor is energized
 Note that the Status LED indicates that the output contacts have changed state: NO has closed, NC has opened.

OEMs Test & Evaluation Units for OEMs
 Free program expedites evaluation process. See page 3 for details.



Ground Fault Relay Dimensions

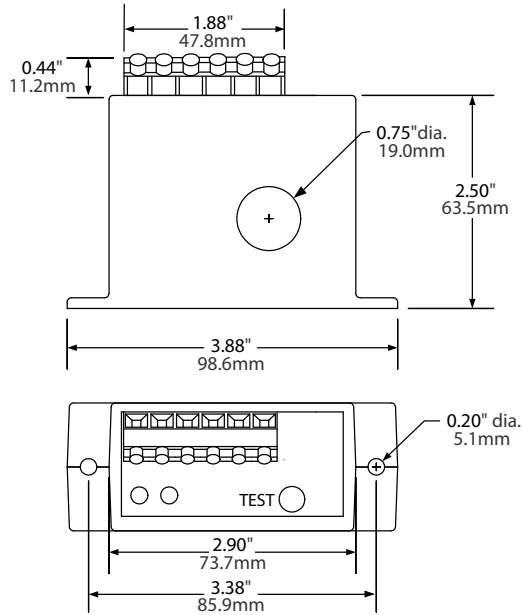

Ground Fault Relay Specifications

| | |
|--------------------------|---|
| Power Supply | 24 VDC (20–26 V) |
| Power Consumption | <4VA |
| Output | Electromechanical relay 1 A @ 120 VAC, 2 A @ 30V DC Max. |
| Output Operation | Normally energized Normally de-energized Latching |
| Output Range | 5–50 mA |
| Response Time | 55 ms maximum |
| Input Range | Up to 1500 VDC (monitored circuit) |
| Isolation Voltage | tested to 5000 V |
| Frequency Range | DC |
| Case | UL94 V-0 Flammability Rated |
| Environmental | -4 to 122°F (-20 to 50°C) 0–95% RH, non-condensing |
| Listings | Designed to meet UL/cUL and CE |

Ground Fault Relay Connections

Auto Reset Connection

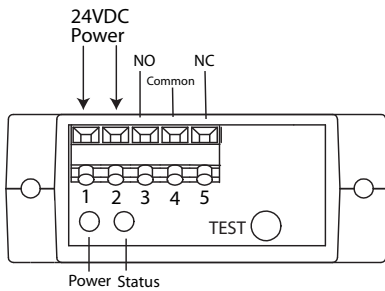

Latching Connection

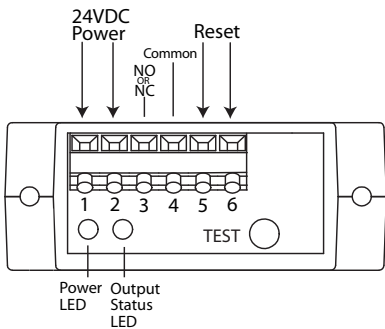

Ground Fault Relay Ordering Information

Sample Model Number: DG1-SDT-24D-ENE-010
DC ground fault relay, output 5–50 mA SPDT relay output, 24 VDC powered, normally energized, 010 factory set trip point.

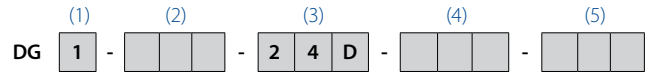

(1) Range

| | |
|---|---------|
| 1 | 5–50 mA |
|---|---------|

(2) Output Type

| | |
|-----|---|
| SDT | Single pole, double throw relay (Auto Reset Only) |
| NCR | Normally Closed, latching model only |
| NOR | Normally Open, latching model only |

(3) Power Supply

| | |
|-----|--------|
| 24D | 24 VDC |
|-----|--------|

(4) Contact Action

| | |
|-----|------------------------------|
| DEN | Normally de-energized output |
| ENE | Normally energized output |
| LA | Latching output |

(5) Trip Point

| | |
|---------|------------------------|
| 005–050 | Factory set trip point |
|---------|------------------------|

Voltage Transducers

NK Technologies' voltage transducers are high-performance transducers for sensing voltage in installations. They are available in an AC or DC Series and come in a variety of nominal voltages.

Features:

- AC or DC models
- Standard 4–20 mA powered output
Industry standard output makes use with existing controllers, data loggers and SCADA equipment easy and reliable
- Input/Output Isolation
Input and output circuitry electrically isolated for improved safety of use
- Compact DIN rail mount case
Transducer housing mounts to standard DIN rail or to a flat panel

- **VTR SERIES**
AC Voltage Transducerspage 112
- **VTD SERIES**
DC Voltage Transducers.....page 114
- **VTD-BD SERIES**
DC Voltage Transducers.....page 116
- **VTU-OS SERIES**
High Voltage DC/AC Voltage Transducerspage 118
- **VTU-DIN SERIES**
AC or DC Voltage Transducers.....page 120

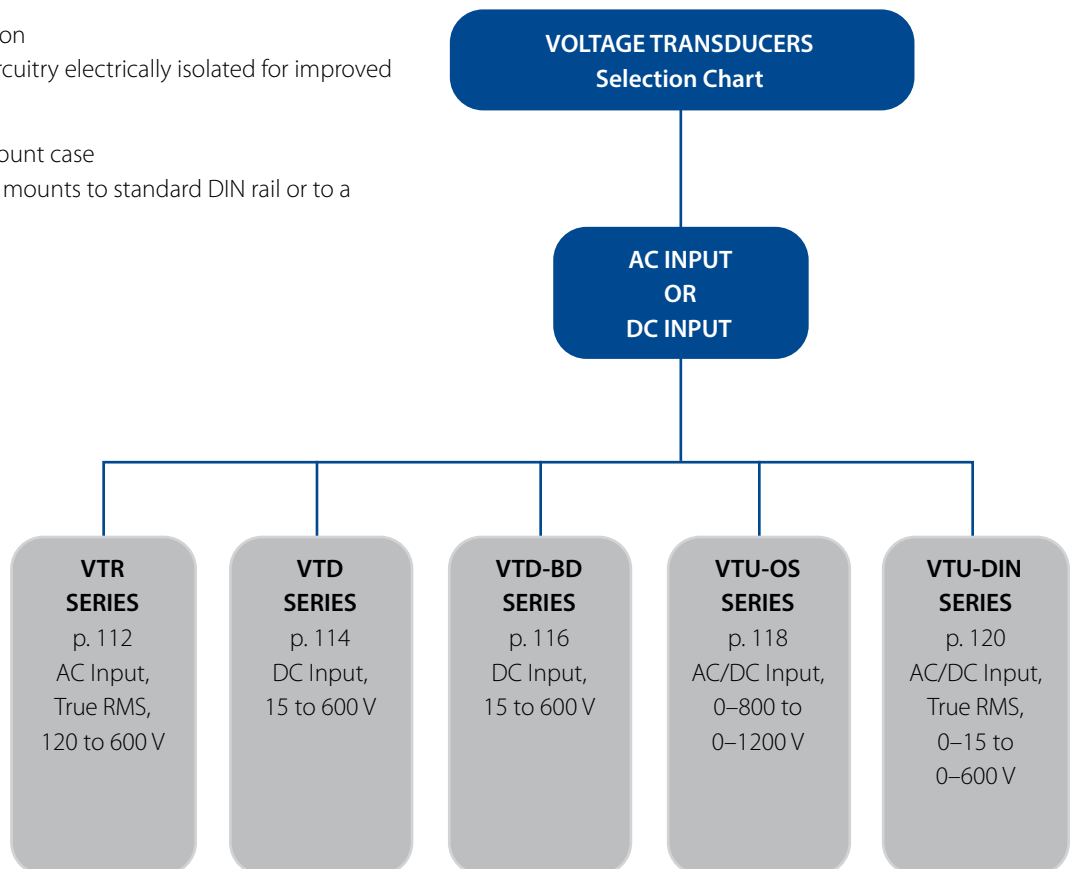

VTR SERIES

AC Voltage Transducers

VTR Series AC Voltage Transducers are high-performance True RMS transducers for sensing voltage in single- and three-phase installations. Applicable on circuits of 120 V, 240 V, 480 V and 600 V, the VTR Series voltage transducers provide a fully isolated, 4–20 mA output proportional to rated voltage in sinusoidal situations. Housed in a slim, compact, easy-to-install DIN mounted rail case, the VTR Series comes in a variety of voltage ranges.



Voltage Transducers

Voltage Transducer Applications

True RMS Voltage Monitoring

- Detect below normal or “brown out” voltage conditions; protect against possible motor overheating.
- Identify phase loss conditions by detecting voltage reduction in one or more phase of three-phase motor.
- Monitor over voltage conditions associated with regenerative voltage to help in diagnosing/avoiding motor drive issues.
- Detect voltage conditions which may cause stress in or damage to soft starter components (SCRs).

Phase Loss Protection

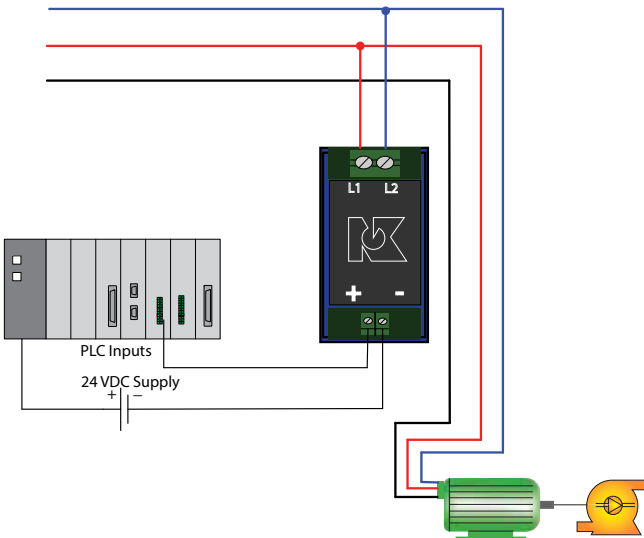

For additional Application Examples, go to www.nktechnologies.com/applications

Voltage Transducer Features

True RMS Output

- Allows for use in situations where power supplied is poor power quality or other electrically harsh/challenging environments.

Standard 4–20 mA Loop-powered Output

- Industry standard output makes use with existing controllers, data loggers and SCADA equipment easy and reliable.

Input/Output Isolation

- Input and output circuitry electrically isolated for improved safety of use.

Compact DIN Rail Mounted Case*

- Space saving, slim enclosure mounts quickly for an attractive installation.

UL/cUL and CE Approved

- Accepted worldwide.

*For information on the DIN rail accessories kit, see page 147.

Voltage Transducer Dimensions

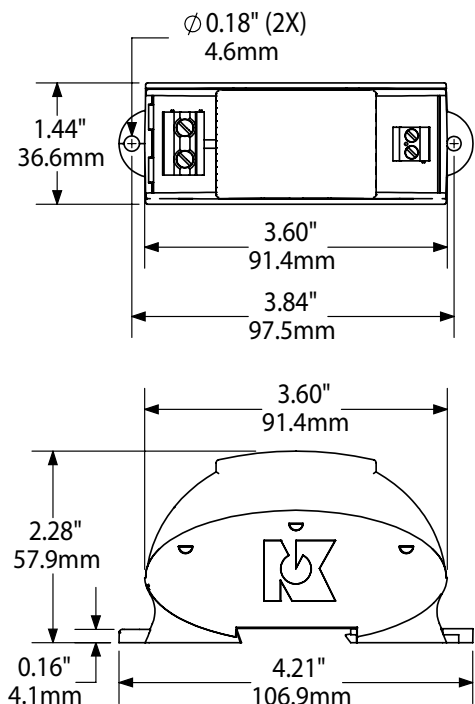

Voltage Transducer Specifications



| | |
|---|---|
| Power Supply | 24 VDC loop-powered (12–40 VDC) |
| Input Range: Input Impedance | 50-150 V: 73 K Ω , 240-300 V: 46 K Ω , 400-500 V: 300 K Ω , 600 VAC: 365 K Ω |
| Output Signal | 4–20 mA proportional |
| Output Limit | 24 mA |
| Output Loading | 500 Ω max. loop impedance |
| Overload | 130% of range |
| Response Time | 250 ms (to 90% of step change) |
| Accuracy | 1.0% FS at 60 Hz (25-100% of range) (2.5% FS at 50 Hz) |
| Isolation Voltage | UL listed to 2200 VAC |
| Frequency Range | 40–100 Hz |
| Case | UL94 V-0 Flammability Rated |
| Environmental | -4 to 122°F (-20 to 50°C) 0–95% RH, non-condensing |
| Listings | UL/cUL, CE |

Voltage Transducer Ordering Information

Sample Model Number: VTR1-420-24L-DIN
True RMS voltage transducer with 120 V voltage range, standard 4–20 mA proportional output; 24 V loop-powered with a DIN rail compatible case.



(1) Voltage Range

| | |
|---|-------|
| 1 | 120 V |
| 2 | 150 V |
| 3 | 240 V |
| 4 | 480 V |
| 5 | 500 V |
| 6 | 600 V |

(2) Output Type

| | |
|-----|---------|
| 420 | 4–20 mA |
|-----|---------|

(3) Supply Voltage

| | |
|-----|---------------------|
| 24L | 24 VDC loop-powered |
|-----|---------------------|

(4) Case

| | |
|-----|---------------------|
| DIN | DIN rail compatible |
|-----|---------------------|

Voltage Transducer Connections

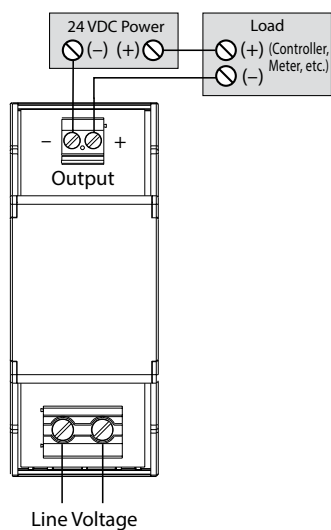

Voltage Transducers

OEMs Test & Evaluation Units for OEMs
Free program expedites evaluation process. See page 3 for details.



VTD SERIES

DC Voltage Transducers

VTD Series Voltage Transducers are high-performance transducers for sensing voltage in DC powered installations. Applicable for use on circuits to 600 VDC, VTD voltage transducers provide fully isolated 0–5 VDC, 0–10 VDC, and 4–20 mA outputs proportional to rated nominal voltage in DC circuits. Housed in a slim, compact, easy-to-install DIN rail mounted case, the VTD Series comes in a variety of nominal voltages.



Voltage Transducer Applications

Voltage Monitoring

- Detect below normal or “brown out” voltage conditions; protect against possible motor overheating.
- Identify conductor loss conditions by detecting voltage reduction in one motor lead.
- Monitor over voltage conditions associated with regenerative voltage to help in diagnosing/avoiding motor drive issues.
- Detect voltage conditions that may cause stress or damage to soft starter components (SCRs).

Voltage Transducer Features

Accurate Output

- Several ranges available for your application, from 0–15 VDC to 0–600 VDC.

Standard Current and Voltage Sensor Outputs

- Industry standard outputs makes use with existing controllers, data loggers and SCADA equipment easy and reliable.

Input/Output Isolation

- Input and output circuitry electrically isolated for improved safety of use.

Compact DIN Mounted Rail Case*

- Space saving slim enclosure mounts quickly for an attractive installation.

UL/cUL and CE Approved

- Accepted worldwide.

*For information on the DIN rail accessories kit, see page 147.

DC Voltage Transducer Control

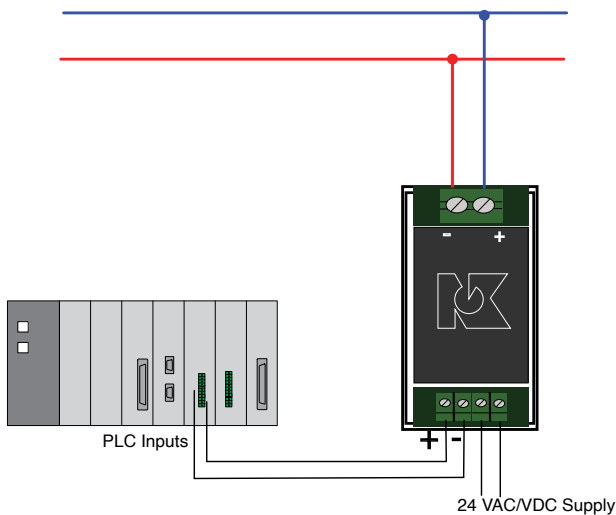

For additional Application Examples, go to www.nktechnologies.com/applications

Voltage Transducer Dimensions

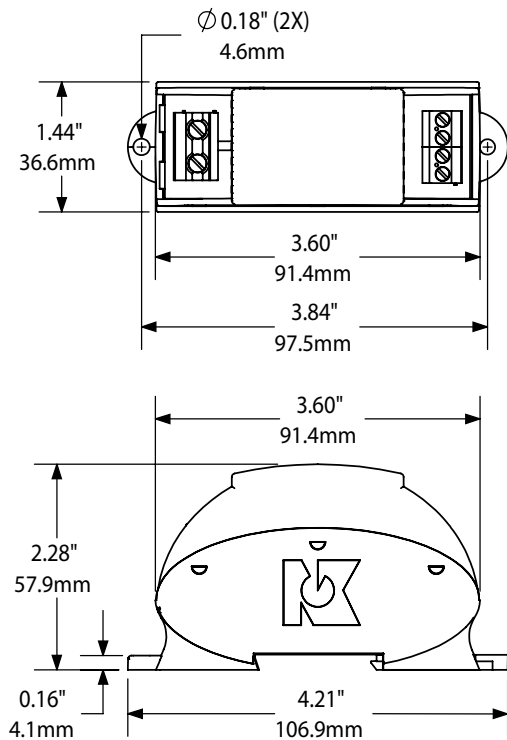

Voltage Transducer Connections

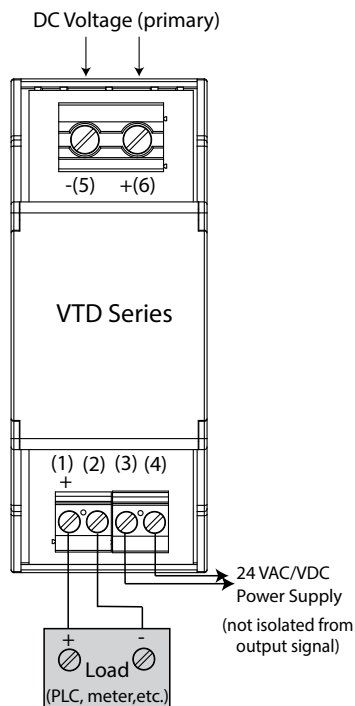

Voltage Transducer Specifications



| | |
|---|---|
| Power Supply | 24 VAC/VDC (20–45 VDC, 22–38 VAC); power supply and output are not isolated |
| Power Consumption | <2 VA |
| Input Range: Input Impedance | 15 V: 25 K Ω , 25 V: 42 K Ω , 50 V: 82 K Ω , 150 V: 250 K Ω , 300 V: 500 K Ω , 600 V: 1.00 M Ω |
| Output Signal | • 4–20 mA (capped at 24 mA max.) • 0–5 VDC (capped at 5.75 VDC) • 0–10 VDC (capped at 11.5 VDC) |
| Output Loading | • 4–20 mA output: <500 Ω • 0–5/10 VDC output: >10 K Ω |
| Response Time | 250 ms (90% step change) |
| Accuracy | <1% FS |
| Isolation Voltage | 2200 VAC |
| Frequency Range | DC |
| Case | UL94 V-0 Flammability Rated |
| EMC/Immunity | EN50081-1, EN50082-2 |
| Ripple | <1% (peak to peak) |
| Environmental | -4 to 140°F (-20 to 60°C) 0–95% RH, non-condensing |
| Listings | UL/cUL, CE |

Voltage Transducer Ordering Information

Sample Model Number: VTD1-420-24U-DIN

DC voltage transducer with 25 VDC range, standard 4–20 mA proportional output; 24 VAC/VDC externally powered with a DIN rail compatible case.



(1) Nominal Range

| | |
|---|-----------|
| 0 | 0–15 VDC |
| 1 | 0–25 VDC |
| 2 | 0–50 VDC |
| 3 | 0–150 VDC |
| 4 | 0–300 VDC |
| 5 | 0–600 VDC |

(2) Output Type

| | |
|-----|----------|
| 005 | 0–5 VDC |
| 010 | 0–10 VDC |
| 420 | 4–20 mA |

(3) Supply Voltage

| | |
|-----|----------------------------------|
| 24U | 24 VAC/VDC external power supply |
|-----|----------------------------------|

(4) Case

| | |
|-----|---------------------|
| DIN | DIN rail compatible |
|-----|---------------------|



Test & Evaluation Units for OEMs

Free program expedites evaluation process. See page 3 for details.



VTD-BD SERIES

DC Voltage Transducers

VTD-BD Series Voltage Transducers are high-performance transducers for sensing voltage in DC powered installations. Applicable for use on circuits to 600 VDC, VTD-BD voltage transducers provide a fully isolated +/- 5 VDC or +/- 10 VDC output signal in response to DC voltages that change polarity. Housed in an easy-to-install DIN rail or panel mount case, the VTD-BD Series comes in a variety of ranges to suit many primary voltages.



Voltage Transducer Applications

Voltage Monitoring

- Detect below normal or “brown out” voltage conditions; protect against possible motor overheating.
- Identify conductor loss conditions by detecting voltage reduction in one motor lead.
- Monitor over voltage conditions associated with regenerative voltage to help in diagnosing/avoiding motor drive issues.
- Detect voltage conditions that may cause stress in or damage to soft starter components (SCRs).

DC Voltage Transducer

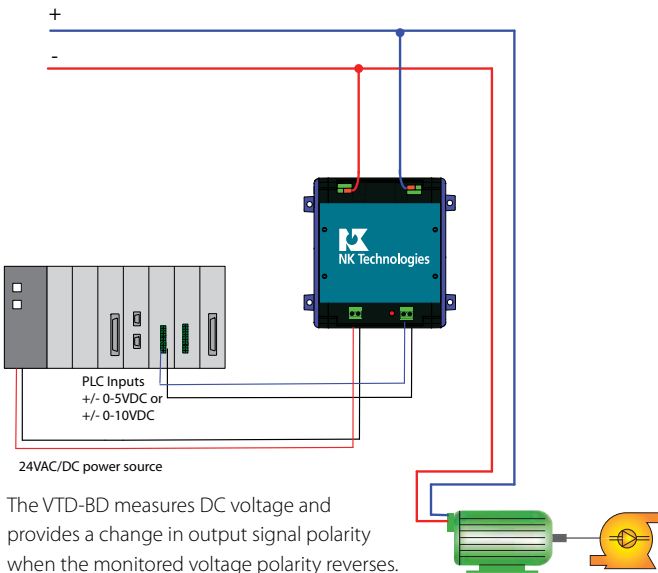

The VTD-BD measures DC voltage and provides a change in output signal polarity when the monitored voltage polarity reverses. Positive on upper right terminal creates a positive output signal; positive on upper left terminal creates a negative output signal.

Voltage Transducer Features

Wide Input Range Selection

- Six ranges of input voltages to best fit your requirements, from +/- 0–15 VDC to +/- 0–600 VDC.

+/- 5 VDC or +/- 10 VDC Sensor Powered Outputs

- Industry standard outputs makes use with existing controllers, data loggers and SCADA equipment easy and reliable.

Input/Output Isolation

- Input and output circuitry electrically isolated for improved safety of use.

DIN Rail or Panel Mount Case*

- Enclosure mounts quickly for an attractive installation.

UL/cUL and CE Approved

- Accepted worldwide.

*For information on the DIN rail accessories kit, see page 147.

For additional Application Examples, go to www.nktechnologies.com/applications

Voltage Transducer Dimensions

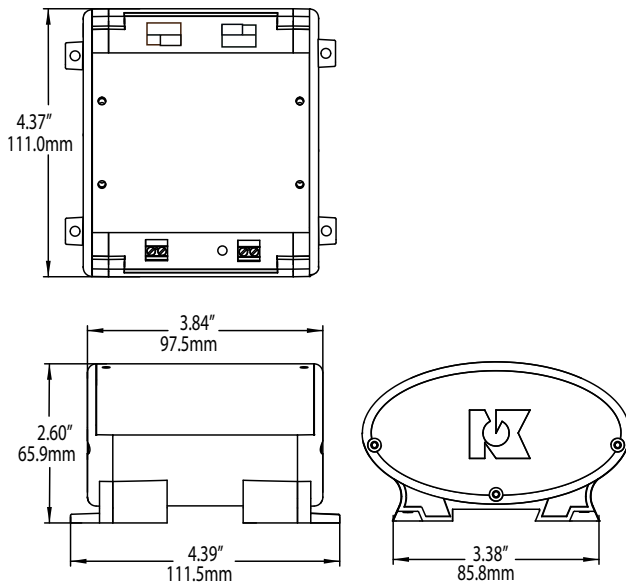

Voltage Transducer Connections

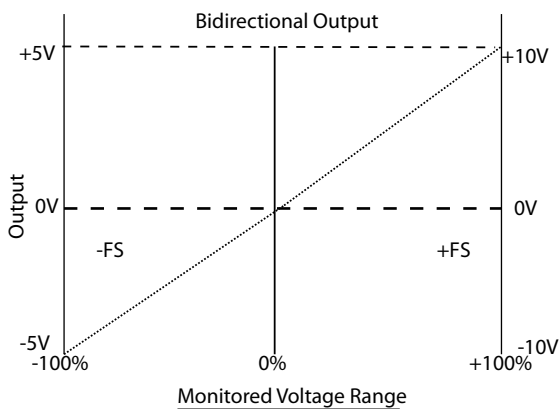
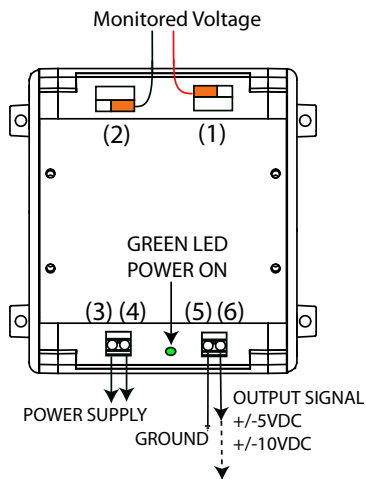

Voltage Transducer Specifications



| | |
|--------------------------|---|
| Power Supply | 24 VAC/DC (22–26V); power supply is isolated from output signal |
| Power Consumption | <2VA |
| Input Range (+/-) | 15 V, 25 V, 50 V, 150 V, 300 V, 600 VDC |
| Input Impedance | >160K Ω |
| Output | • +/-5 VDC • +/-10 VDC |
| Output Impedance | >10K Ω |
| Response Time | 500 ms (10–90% step change) |
| Accuracy | 1.0% of FS |
| Isolation Voltage | 2500 V |
| Frequency Range | DC |
| Case | UL94 V-0 Flammability Rated |
| Environmental | -4 to 122°F (-20 to 50°C) 0–95% RH, non-condensing |
| Listings | UL/cUL, CE |

Voltage Transducer Ordering Information

Sample Model Number: VTD0-010-24U-BD-OS
DC voltage transducer with 15 V range, +/-10 VDC proportional output; 24 V externally powered, bidirectional output with a DIN rail compatible case.

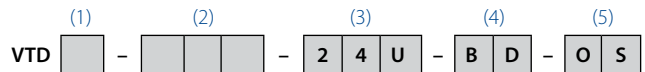

(1) Nominal Range

| | |
|---|----------|
| 0 | +/-15 V |
| 1 | +/-25 V |
| 2 | +/-50 V |
| 3 | +/-150 V |
| 4 | +/-300 V |
| 5 | +/-600 V |

(2) Output Signal

| | |
|-----|-----------|
| 005 | +/-5 VDC |
| 010 | +/-10 VDC |

(3) Supply Voltage

| | |
|-----|---------------------------------|
| 24U | 24 VAC/DC external power supply |
|-----|---------------------------------|

(4) Output Type

| | |
|----|----------------------|
| BD | Bidirectional output |
|----|----------------------|

(5) Case

| | |
|----|-------------------------|
| OS | DIN rail or panel mount |
|----|-------------------------|

Voltage Transducers

OEMs Test & Evaluation Units for OEMs
Free program expedites evaluation process. See page 3 for details.



VTU-OS SERIES

High Voltage DC/AC Voltage Transducers

VTU-OS Series Voltage Transducers provide very high accuracy and safety in a panel or DIN rail mounted case. The one sensor design can measure DC or AC circuit voltages to 1200 volts, and produce an analog signal directly proportional to the voltage connected. This provides a very valuable tool to spot issues with power generation (conventional and alternative sources) like brownouts and phase loss. The voltage will be present on the line side of a disconnect even when the breaker or switch is open.



Voltage Transducers

Voltage Transducer Applications

Photovoltaic Panels

- Connecting panel outputs in series increases the voltage sent from the panels to the load up to 1200 volts DC. The VTU is designed to measure this safely.

Water Delivery and Treatment

- Measure the AC voltage to pumps and aerators and shut them down if the supplied voltage falls to a dangerous level.

Cranes and Lifting Apparatus

- DC motors are used to lift, place and position heavy objects, as they have full torque capacity at zero speed. Use a voltage transducer to be sure that the field windings have voltage to keep the motor speed under control.

Voltage Transducer Features

Industry Standard Output Options

- 4–20 mA, 0–5 and 0–10 VDC.
- Compatible with most automation and control systems.
- Output proportional to RMS voltage.

Externally Powered

- 24 VAC or DC with low power consumption.

Simple Conductor Termination

- Primary circuit uses self-tightening terminals.
- Power supply and output terminals are finger-safe.

Panel or DIN Rail Mount Options*

- If a DIN rail is not available, use the screw mounting option to attach to a back panel.
- Power supply is isolated from input and output.

UL/cUL Approved, CE Pending

- Accepted worldwide.

*For information on the DIN rail accessories kit, see page 147.

VTU-OS Measures Both AC and DC Voltages

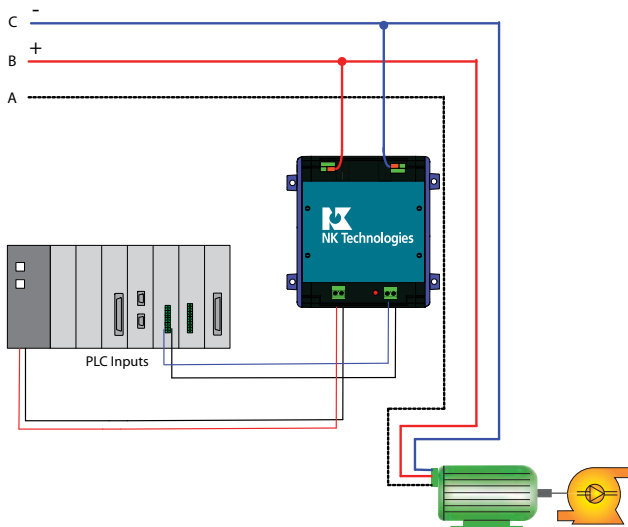



Voltage Transducer Dimensions

OS Case

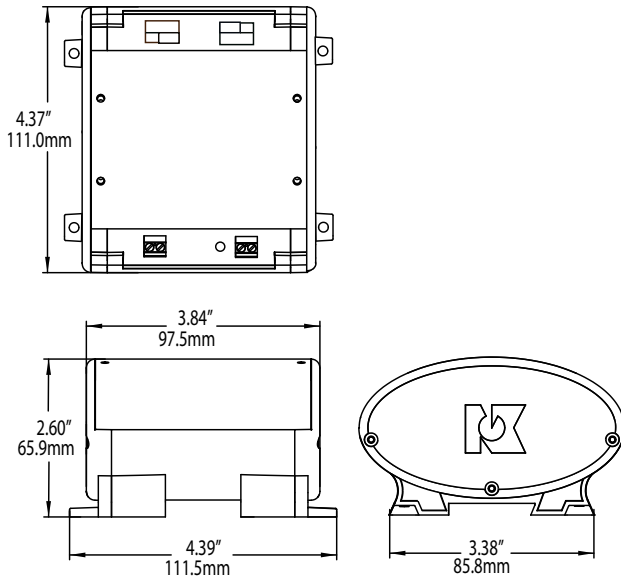

Voltage Transducer Specifications

| | |
|--------------------------|--|
| Power Supply | 24 VAC/DC (22–26 VAC or DC); power supply is isolated from output signal |
| Power Consumption | <2 VA |
| Input Range | 0–800, 1000 or 1200 VAC or DC |
| Output | <ul style="list-style-type: none"> • 4–20 mA • 0–5 VDC • 0–10 VDC |
| Output Loading | <ul style="list-style-type: none"> • 4–20 mA: <400 Ω • 0–5/10 VDC: >100 KΩ |
| Response Time | 100 ms |
| Accuracy | <1% FS |
| Isolation Voltage | UL listed to 1270 VAC, tested to 5 KV |
| Frequency Range | 0–400 Hz |
| Case | UL94 V-0 Flammability Rated |
| Environmental | -4 to 122 ° F (-20 to 50° C) 0–95% RH, non-condensing |
| Listings | UL/cUL, CE pending |

Voltage Transducer Connections

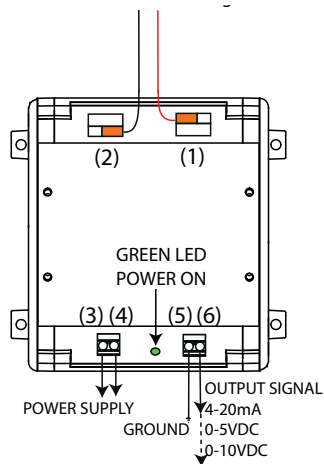

Voltage Transducer Ordering Information

Sample Model Number: VTU10-420-24U-OS
AC or DC voltage transducer, 0–1000 V primary, 4–20 mA secondary, 24 VAC/DC power, DIN or panel mount case.



(1) Range

| | |
|----|----------|
| 8 | 0–800 V |
| 10 | 0–1000 V |
| 12 | 0–1200 V |

(2) Output Type

| | |
|-----|----------|
| 005 | 0–5 VDC |
| 010 | 0–10 VDC |
| 420 | 4–20 mA |

(3) Supply Voltage

| | |
|-----|---------------------------------|
| 24U | 24 VAC/DC external power supply |
|-----|---------------------------------|

(4) Case Style

| | |
|----|---------------------------------|
| OS | DIN rail or panel mounting case |
|----|---------------------------------|

Voltage Transducers

OEMs Test & Evaluation Units for OEMs
Free program expedites evaluation process. See page 3 for details.



VTU-DIN SERIES

AC or DC Voltage Transducers

VTU-DIN Series Voltage Transducers are high-performance True RMS transducers for sensing voltage in single, three-phase or DC installations. Housed in a slim, compact, easy-to-install DIN rail mounted case, these transducers come in a variety of voltage ranges. The VTU-DIN measures AC or DC voltage from 0–15 to 0–600 V and provides an industry standard output proportional to connected voltage in alternating current circuits with sinusoidal or non-sinusoidal (variable frequency) applications or direct current circuits.



Voltage Transducers Applications

True RMS or DC Voltage Monitoring

- Detect below normal or “brownout” voltage conditions; protect against possible motor overheating.
- Identify phase loss conditions by detecting voltage reduction in one or more phase of three-phase motor.
- Monitor over voltage conditions associated with regenerative voltage to help in diagnosing/avoiding motor drive issues.
- Detect voltage conditions that may cause stress or damage to soft starter components (SCRs).

Phase Loss Detection

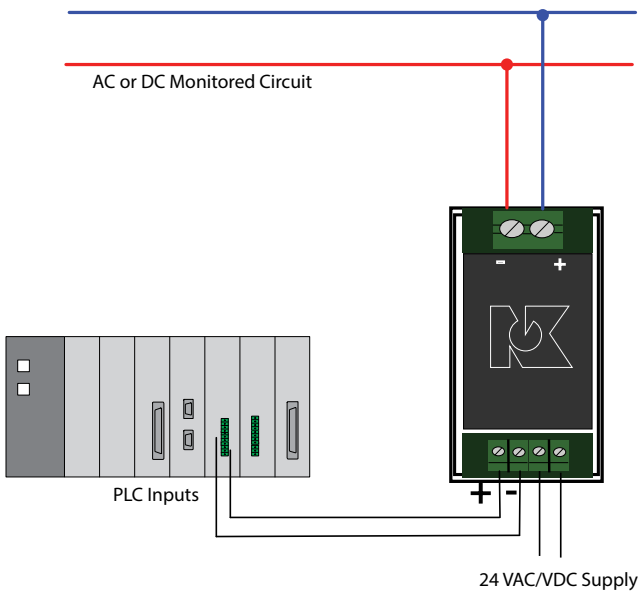

Voltage Transducers Features

Zero to 5 KHz Measurement

- Allows for use in situations where power supplied is non-sinusoidal such as VFD applications, poor power quality installations or other electrically harsh/challenging environments.

Standard Outputs

- Industry standard outputs makes use with existing controllers, data loggers and SCADA equipment easy and reliable.

Compact DIN Rail Mount Case*

- Space saving slim enclosure mounts quickly for an attractive installation.

UL/cUL and CE Approved

- Accepted worldwide.

*For information on the DIN rail accessories kit, see page 147.

Voltage Transducers Dimensions

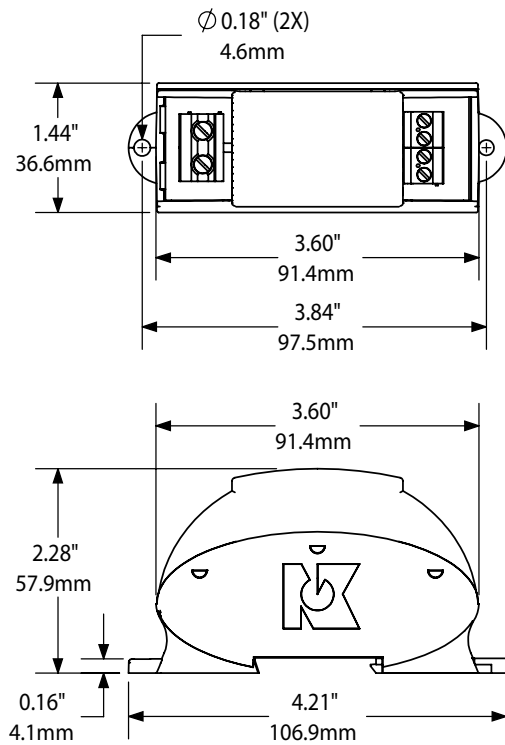

Voltage Transducers Specifications



| | |
|---|--|
| Power Supply | 24 VAC or VDC external power (22-26 VAC/VDC) (Not isolated from the output) |
| Power Consumption | <2 VA |
| Input Range: Input Impedance | 15, 25, 50, 60: >220 K Ω , 120: >410 K Ω , 150, 240, 300, 400, 500, 600 VAC/VDC: 620 K Ω |
| Output Signal | • 4–20 mA proportional (capped at 31 mA max.) • 0–5 VDC (capped at 7.75 VDC) • 0–10 VDC (capped at 11.5 VDC) |
| Response Time | 500 ms (to 90% of step change) |
| Accuracy | <1% FS error |
| Output Loading | • 4–20 mA output: <400 Ω • 0–5/10 VDC output: >50 K Ω |
| Isolation Voltage | 2200 VAC |
| Frequency Range | 0 Hz–5 KHz |
| Case | UL94 V-0 Flammability Rated; noncorrosive thermoplastic |
| Environmental | -4 to 122°F (-20 to 50°C) Surrounding Air 0–95% RH, non-condensing |
| Listings | UL/cUL, CE |

Voltage Transducers Connections

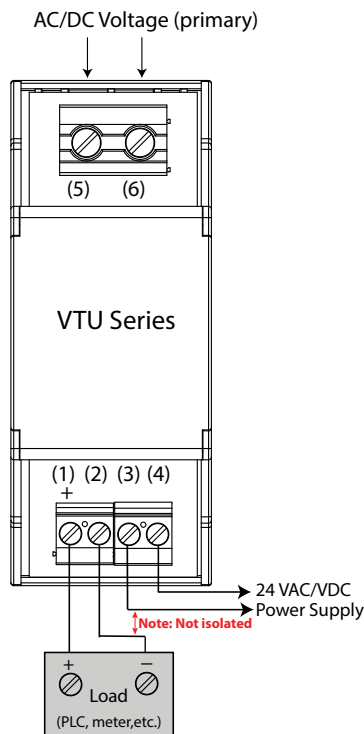

Voltage Transducer Ordering Information

Sample Model Number: VTUE-420-24U-DIN
AC/DC voltage transducers with 120 V range, standard 4–20 mA proportional output; 24 VAC/VDC externally powered with a DIN rail compatible case.



(1) Range

| | |
|---|---------|
| A | 0–15 V |
| B | 0–25 V |
| C | 0–50 V |
| D | 0–60 V |
| E | 0–120 V |
| F | 0–150 V |
| G | 0–240 V |
| H | 0–300 V |
| I | 0–400 V |
| J | 0–500 V |
| K | 0–600 V |

(2) Output Type

| | |
|-----|----------|
| 420 | 4–20 mA |
| 005 | 0–5 VDC |
| 010 | 0–10 VDC |

(3) Power Supply

| | |
|-----|----------------------------------|
| 24U | 24 VAC/VDC external power supply |
|-----|----------------------------------|

(4) Mounting

| | |
|-----|---------------------|
| DIN | DIN rail compatible |
|-----|---------------------|

OEMs

Test & Evaluation Units for OEMs

Free program expedites evaluation process. See page 3 for details.



Power Sensing Products

NK Technologies' power monitoring sensors measure loads and improve performance by providing instantaneous True Power kW or accumulated kWh data. They are simple, reliable and accurate. Digital communications are available in some models. Contact the factory or a local distributor for more information.

Features:

- 4–20 mA, 0–10 VDC, and/or networked outputs
- Accepts standard 5 A or 0–333 mV CT inputs
- DIN rail compatibility

- **APN SERIES**
Power Monitorspage 123
- **APN-R SERIES**
Power Monitorspage 125
- **APS SERIES**
Power Transducers.....page 127
- **APT SERIES**
Power Transducers.....page 129
- **APT-TH SERIES**
Power Transducers.....page 131

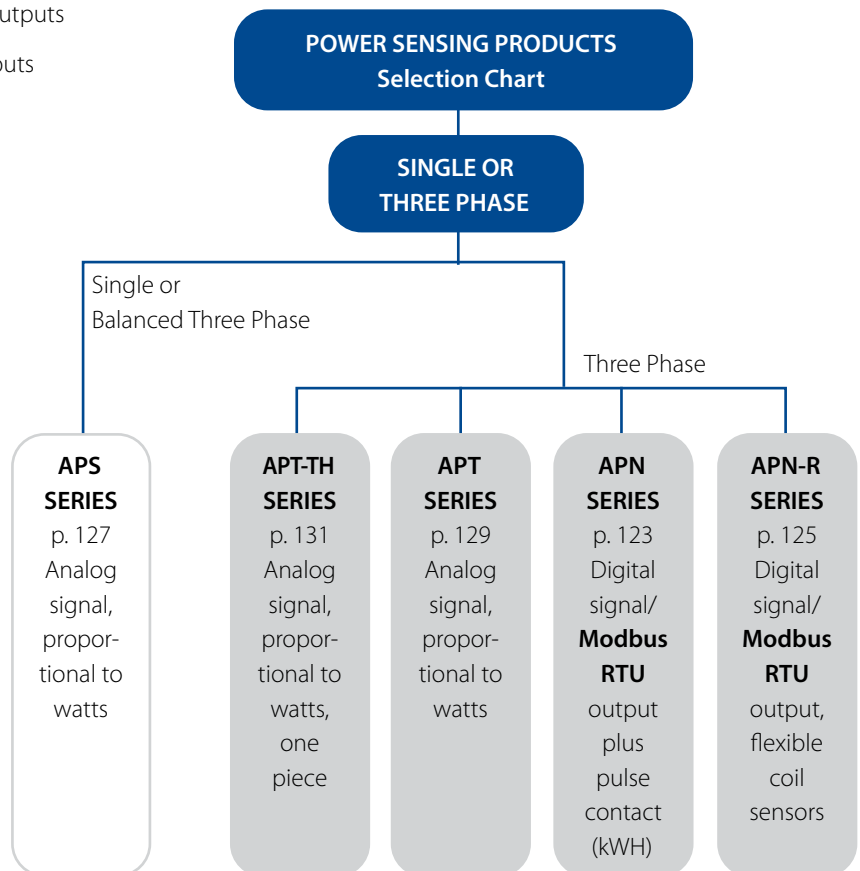

APN SERIES

Power Monitors

APN Series Power Monitors measure three phases of current and voltage and computes 14 values necessary to track power usage. These monitors use current transformers to measure the amperes. The line voltage connects directly to the transducer, up to 600 VAC. The result is 14 data points in the RS485 **Modbus RTU** format. There is also a pulse contact which opens and closes as watt hours are accumulated. The APN can be configured to accept 5 A secondary current transformers or the safer ProteCT™ low voltage output CTs. Either type will produce an accurate set of data to help you save energy and avoid utility surcharges.



APN Power Monitor with **Modbus RTU** Output

Power Monitoring Applications

Plant Energy Management

- Measure the power usage of a single piece of equipment, an area of a plant, or the entire facility.

Conveyors

- Detect jams and overloads.
- Check that the belt is loaded properly by measuring the power consumption.

Pump Monitoring

- Detect dry run from clogged, intake, or discharge line.
- Monitor impeller cavitation and bearing wear.

Pump Jam & Suction Loss Protection

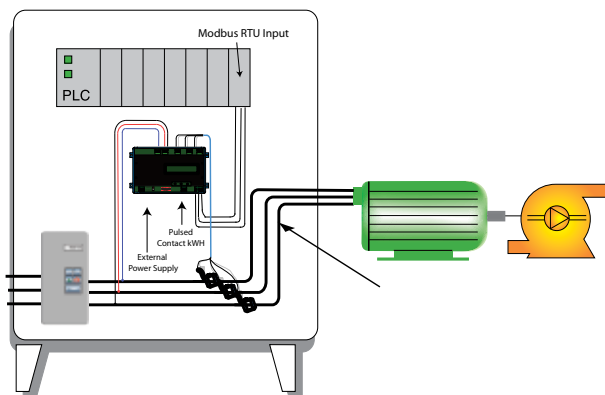

- For additional Application Examples, go to www.nktechnologies.com/applications

Power Monitoring Features

Modbus RTU Output

- RS485 communication protocol reduces the cost involved with proprietary data logging software.
- Compatible with most automation systems.

Externally Powered

- Improves reliability when used in conditions where power interruptions and voltage sags are common.

Compact DIN Rail* or Panel Mounted Case

- Clearly labeled terminals provide quick installation.
- Low profile reduces cabinet depth requirements.

LED Displays Network Communication

- Provides quick visual indication that network is operational.

Finger Safe Terminals

- Safe and secure connectors.

UL/cUL Approved

- Accepted worldwide.

*For information on the DIN rail accessories kit, see page 147.



Power Monitoring Dimensions

Case Front View

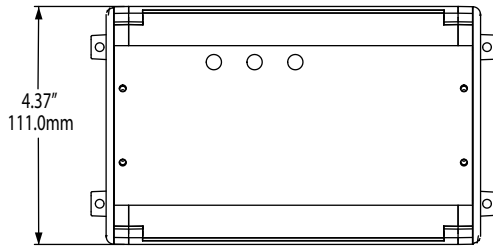

Case Top View

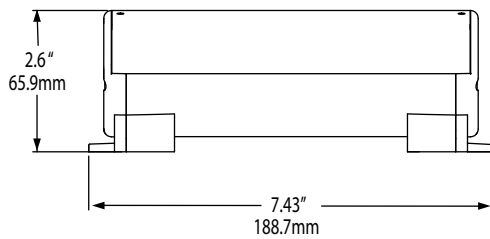

Case Side View

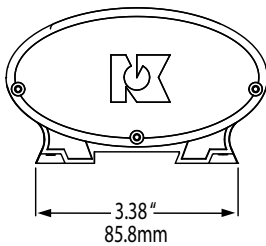

Power Monitoring Connections

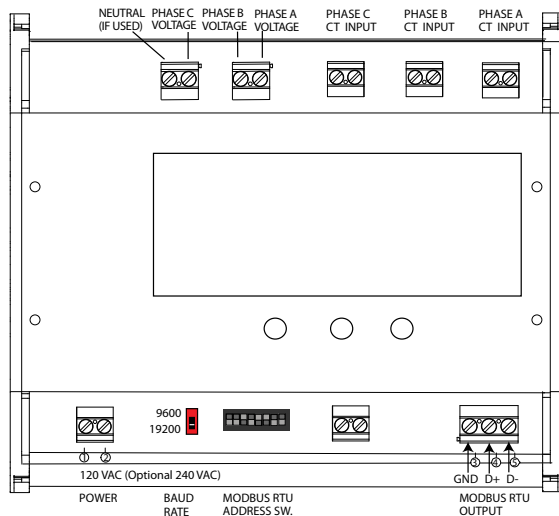

Power Monitoring Specifications



| | |
|--------------------------|---|
| Power Supply | <ul style="list-style-type: none"> • 24 VAC/DC (21–27 V) • 120 VAC (100–125 V) • 240 VAC (200–250 V) |
| Power Consumption | <ul style="list-style-type: none"> • 24 VAC/DC: <100 mA • 120 VAC: <50 mA • 240 VAC: <25 mA |
| Measurement | <ul style="list-style-type: none"> 5A CT input: 3000 A 0.333 mV input: 1500 A |
| Primary Voltage | 100 to 600 VAC |
| Output | <ul style="list-style-type: none"> • Modbus RTU - 14 Data Points • Pulsed Contact KWH |
| Accuracy | <1% FS |
| Response Time | 120 ms |
| Isolation Voltage | Tested to 4 KV |
| Frequency Range | 50–60 Hz |
| Case | UL94 V-0 Flammability Rated |
| Environmental | <ul style="list-style-type: none"> -4 to 122°F (-20 to 50°C) 0–95% RH, non-condensing |
| Listings | UL/cUL approved |

Power Monitoring Data Point Table

| | Phase A | Phase B | Phase C | Type |
|---------------------|---------|---------|---------|---------------|
| Current | ● | ● | ● | RMS |
| Voltage | ● | ● | ● | RMS |
| kW | ● | ● | ● | Active |
| Power Factor | ● | ● | ● | Instantaneous |
| Power Factor | | | | Average |
| kWH | | | | Total |

Power Monitoring Ordering Information

Sample Model Number: APN-600-MV-120-MOD
 AC power transducer, 600 VAC maximum input, ProteCT™ current inputs, 120 VAC powered, RS485 **Modbus** output with pulse contact for kWh.



(1) Maximum Primary Voltage

| | |
|-----|---------|
| 600 | 600 VAC |
|-----|---------|

(2) Current Input Type

| | |
|-----|---|
| MV | ProteCT™ current transformers, 333 mVAC secondary |
| 5 A | 5 A secondary current transformers |

(3) Rating Power Supply

| | |
|-----|-------------------------|
| 24U | 24 VAC/DC (100 mA max.) |
| 120 | 120 VAC (50 mA max.) |
| 240 | 240 VAC (25 mA max.) |

(4) Output Type

| | |
|-----|---|
| MOD | Modbus RTU (RS485), pulse contact for kWh |
|-----|---|

OEMs Test & Evaluation Units for OEMs
 Free program expedites evaluation process. See page 3 for details.

APN-R SERIES

Power Monitors

The APN-R Series Power Monitors measure three phases of current and voltage and computes 14 values necessary to track power usage. These monitors use flexible current sensors to measure the amperes, and the line voltage connects directly to the transducer, up to 600 VAC. The result is 14 data points in the RS485 **Modbus RTU** format. There is also a pulse contact which opens and closes as watt hours are accumulated. The APN-R is factory configured with specifically matched flexible coils. The ease of installation over multiple conductors or bus assemblies will speed installation and produce an accurate set of data to help you identify areas of excessive energy consumption and allow intervention to reduce demand.



Power Monitoring Applications

Plant Energy Management

- Measure the power usage of a single piece of equipment, an area of a plant, or the entire facility.

Conveyors

- Detect jams and overloads.
- Check that the belt is loaded properly by measuring the power consumption.

Pump Monitoring

- Detect dry run from clogged, intake, or discharge line.
- Monitor impeller cavitation and bearing wear.

Pump Jam & Suction Loss Protection

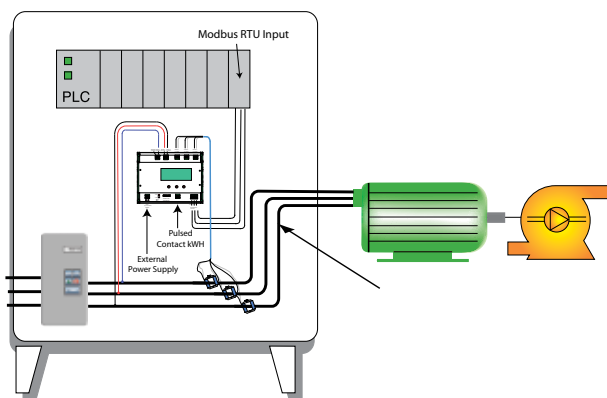

Power Monitoring Features

Modbus RTU Output

- RS485 communication protocol reduces the cost involved with proprietary data logging software.
- Compatible with most automation systems.

Externally Powered

- Improves reliability when used in conditions where power interruptions and voltage sags are common.

Compact DIN Rail* or Panel Mounted

- Clearly labeled terminals provide quick installation.
- Low profile reduces cabinet depth requirements.

LED Displays Network Communication

- Provides quick visual indication that network is operational.

Finger Safe Terminals

- Safe and secure connectors.

UL/cUL Approved

- Accepted worldwide.

*For information on the DIN rail accessories kit, see page 147.

- For additional Application Examples, go to www.nktechnologies.com/applications



APN-R SERIES

791000010 Rev 1

Power Monitoring Dimensions

Case Side View

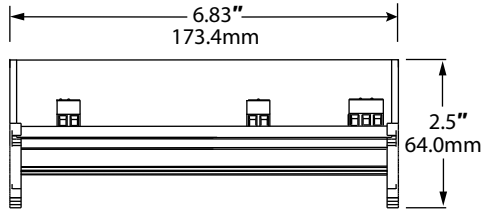

Case Top View

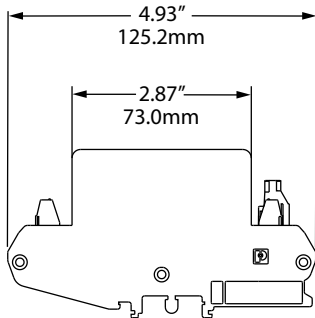

Note: Drawings are not to scale.

Power Monitoring Connections

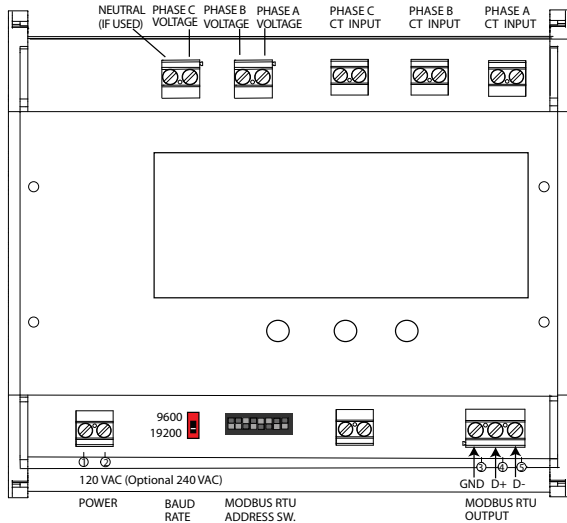

Power Monitoring Specifications



| | |
|--------------------------|---|
| Power Supply | <ul style="list-style-type: none"> • 24 VAC/DC (21–27 V) • 120 VAC (100–125 V) • 240 VAC (200–250 V) |
| Power Consumption | <ul style="list-style-type: none"> • 24 VAC/DC: <100 mA • 120 VAC: <50 mA • 240 VAC: <25 mA |
| Measurement | 2000 A |
| Primary Voltage | 100 to 600 VAC |
| Output | <ul style="list-style-type: none"> • Modbus RTU - 14 Data Points • Pulsed Contact KWH |
| Accuracy | <1% (10 – 100% of range) |
| Response Time | 120 ms |
| Isolation Voltage | Tested to 4 KV |
| Frequency Range | 50/60 Hz |
| Case | UL94 V-0 Flammability Rated |
| Environmental | -4 to 122°F (-20 to 50°C) 0–95% RH, non-condensing |
| Listings | UL/cUL |

Power Monitoring Data Point Table

| | Phase A | Phase B | Phase C | Type |
|---------------------|---------|---------|---------|---------------|
| Current | ● | ● | ● | RMS |
| Voltage | ● | ● | ● | RMS |
| kW | ● | ● | ● | Active |
| Power Factor | ● | ● | ● | Instantaneous |
| Power Factor | | | | Average |
| kWH | | | | Total |

Power Monitoring Ordering Information

Sample Model Number: APN-600-RC1-120-MOD
AC power monitor, 600 VAC maximum input, flexible current inputs (0–500 A range), 120 VAC powered, RS485 **Modbus** output with pulse contact for kWH.



(1) Maximum Primary Voltage

| | |
|-----|---------|
| 600 | 600 VAC |
|-----|---------|

(2) Current Input Type

| | |
|-----|--------------------------------------|
| RC1 | Flexible coil sensors 0–500 A range |
| RC2 | Flexible coil sensors 0–2000 A range |

(3) Rating Power Supply

| | |
|-----|-----------|
| 24U | 24 VAC/DC |
| 120 | 120 VAC |
| 240 | 240 VAC |

(4) Output Type

| | |
|-----|--|
| MOD | Modbus RTU (RS485), pulse contact for kWH |
|-----|--|



Test & Evaluation Units for OEMs

Free program expedites evaluation process. See page 3 for details.



3511 Charter Park Drive • San Jose, CA 95136
800.959.4014 • www.nktechnologies.com • sales@nktechnologies.com



APS SERIES

Power Transducers

APS Series kWh Power Transducers offer an inexpensive way to measure kWh on single- and three-phase balanced loads. The APS Series constantly measures motor power consumption, which is proportional to the amount of work being done and an indication of the motor load. Ideal for mixing, grinding, machining and pumping applications where power measurement is needed, the APS Series includes a CT, voltage sensor and output signal conditioner in a single package designed for easy installation. Available for input currents up to 180 A and voltages up to 600 VAC.



Power Transducer Applications

Grinding and Milling Control

- Measure grinder horsepower; optimize feed rates.

Viscosity Control

- Continuously calculate mixer kW draw; monitor viscosity without entering vessel.

Tool Monitoring and Jam Protection

- Measure drive motor HP to determine tool travel or contact with work.
- Monitor motor horsepower to provide an indication of motor jams.

Crusher/Grinder/Shredder Motor Interlocks

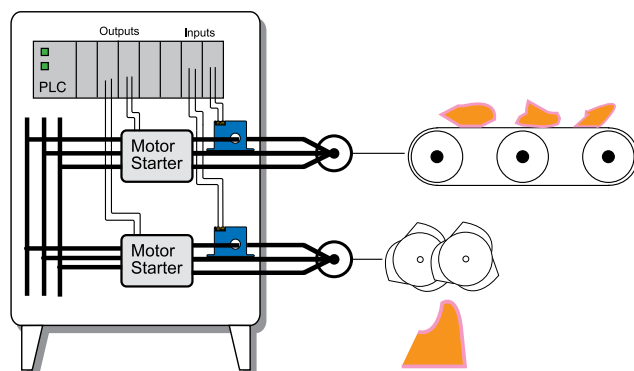

- For additional Application Examples, go to www.nktechnologies.com/applications

Power Transducer Features

True Power Measurement

- Measures true power (HP or kW) on balanced loads; accounts for voltage and power factor fluctuations and improves sensitivity to load changes.
- Requires only one or two power legs for installation.

Fast and Easy Installation

- Current and voltage sensors in one package and 24 VDC loop-powered supply allows for quick and easy two-wire installation.

Factory-calibrated Ranges

- Single range factory calibrated to ensure accuracy.

UL/cUL Approved

- Accepted worldwide.



Power Transducer Dimensions

FL Case

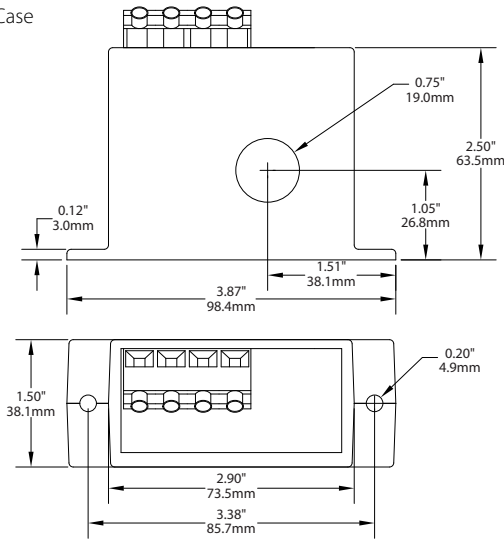

Power Transducer Connections

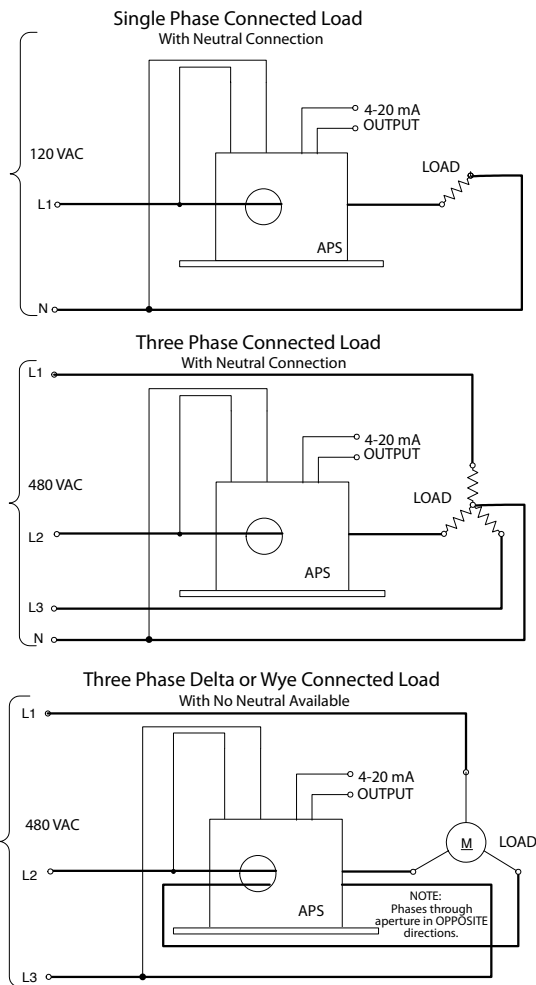

Power Transducer Specifications



| | |
|------------------------------|---|
| Power Supply | 24 VDC loop-powered (12–36 V) |
| Primary Voltage Input | 120, 240, 480 or 600 VAC |
| Output | 4–20 mA proportional to max. KW; 25 mA limit |
| Accuracy | <1% FS |
| Loading | 500 Ω @ 24 VDC |
| Response Time | 100 ms (to 90% of step change) |
| Isolation Voltage | UL listed to 1270 VAC, tested to 5 KV |
| Frequency Range | 50–60 Hz |
| Case | UL94 V-0 Flammability Rated |
| Environmental | -4 to 122°F (-20 to 50°C) 0–95% RH, non-condensing |
| Listings | UL/cUL (except 600 V models) |

Power Transducer Ordering Information

Sample Model Number: APS4-420-24L-10.0

Single phase watt transducer, 10 kW range, 480 VAC input, may be wired with two opposite current wire passes, 4–20 mA output, loop-powered.



(1) Input Voltage

| | |
|---|-------------------------|
| 1 | 120 VAC |
| 2 | 240 VAC |
| 4 | 480 VAC |
| 6 | 600 VAC (not UL listed) |

(2) Output Signal

| | |
|-----|---------|
| 420 | 4–20 mA |
|-----|---------|

(3) Power Supply

| | |
|-----|---------------------|
| 24L | 24 VDC loop-powered |
|-----|---------------------|

(4) Input Range

| | |
|------|---------|
| 0.5 | 0.5 KW |
| 0.75 | 0.75 KW |
| 1.0 | 1.0 KW |
| 2.0 | 2.0 KW |
| 5.0 | 5.0 KW |
| 10.0 | 10 KW |
| 20.0 | 20 KW |
| 50.0 | 50 KW |
| 75.0 | 75 KW |
| 100 | 100 KW |

Note: Not all ranges available for every voltage range. Minimum current for stated accuracy is 2 A, maximum current 180 A.



Test & Evaluation Units for OEMs

Free program expedites evaluation process. See page 3 for details.



APT SERIES

Power Transducers

APT Power Transducers measure three phases of current and voltage, and produce an industry standard analog signal proportional to the watts used. These monitors use current transformers to measure the amperes, and the line voltage connects directly to the transducer, up to 600 VAC. The APT Power Transducer can be configured to accept 5 A secondary current transformers or the safer ProteCT™ low voltage output sensors. Either type of current sensing will produce an accurate output signal to help you identify areas of excessive energy consumption and allow intervention to reduce demand.

Power Transducer Applications

Plant Energy Management

- Measure the power usage of a single piece of equipment, an area of a plant or the entire facility.

Conveyors

- Detects jams and overloads.
- Check that the belt is loaded properly by measuring the power consumption.

Pump Monitoring

- Detect dry run from clogged intake or discharge line.
- Monitor impeller cavitation and bearing wear.

Pump Jam & Suction Loss Protection

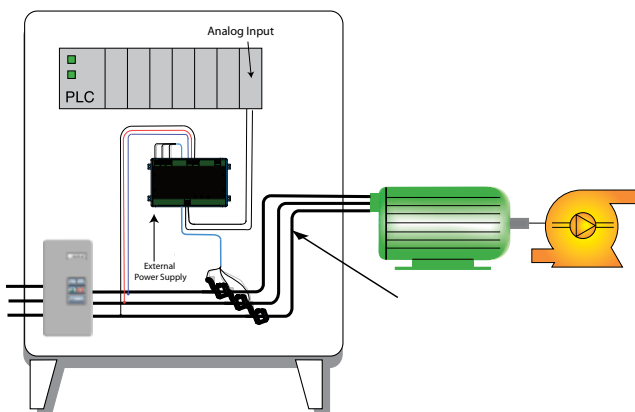

- For additional Application Examples, go to www.nktechnologies.com/applications



APT Power Monitor with Analog Output

Power Transducer Features

Industry Standard Analog Outputs

- Choose 4–20 mA, 0–5 or 0–10 VDC.
- Compatible with most automation systems.

Externally Powered

- Improves reliability when used in conditions where power interruptions and voltage sags are common.

Compact DIN Rail* or Panel Mounted

- Clearly labeled terminals provide quick installation.
- Low profile reduces cabinet depth requirements.

Finger Safe Terminals

- Safe and secure connectors.

UL/cUL Approved

- Accepted worldwide.

*For information on the DIN rail accessories kit, see page 147.

APT Output Values

APT Power Transducers produce full range output. When the current transformer is producing its maximum signal, the primary voltage is at the range maximum and power factor is at unity. As an example, using the APT-480-5 A-120-420 with 400:5 current transformers, the transducer will produce 20 mA when there is 400 A through the CT and the primary voltage is 480. If the transducer is used to monitor a three-phase circuit using three CTs, 20 mA represents 332,544 watts. The equation for three-phase wattage is voltage times amperage, times the square root of three (1.732) times power factor. If this transducer is used to monitor a three-phase load using two CTs, the transducer will produce 14.67 mA, or the output will represent 2/3 of the actual watts being used under the same conditions: 480 V primary voltage, 400 A through 400:5 CTs and unity power factor.



APT SERIES

792000025 Rev 1

Power Transducer Dimensions

Case Front View

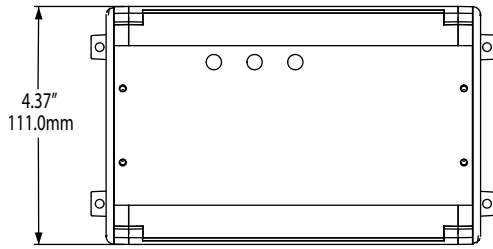

Case Top View

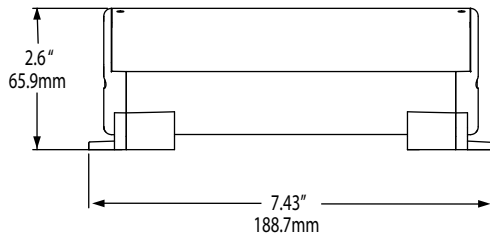

Case Side View

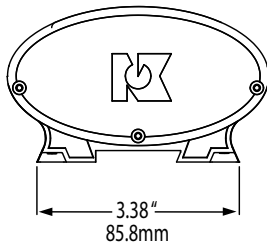

Note: Drawings are not to scale.

Power Transducer Connections

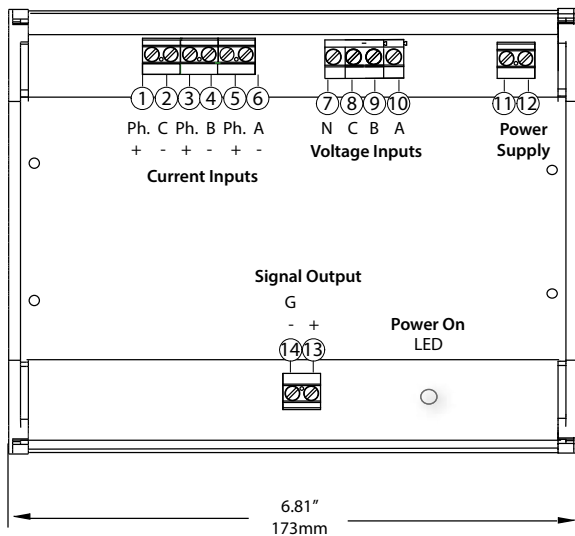

Power Transducer Specifications



| | |
|------------------------------|---|
| Power Supply | <ul style="list-style-type: none"> • 24 VAC/DC (21–26 V) • 120 VAC (108–132 V) • 240 VAC (216–264 V) |
| Power Consumption | <2 VA |
| Primary Voltage Input | 120, 240, 480 or 600 VAC |
| Output | <ul style="list-style-type: none"> • 4–20 mA current • 0–5 or 0–10 VDC |
| Accuracy | <0.5% FS |
| Response Time | 120 ms |
| Isolation Voltage | Tested to 4 KV |
| Frequency Range | 6–100 Hz |
| Case | UL94 V-0 Flammability Rated |
| Environmental | -4 to 122°F (-20 to 50°C) 0–95% RH, non-condensing |
| Listings | UL/cUL |

Power Transducer Ordering Information

Sample Model Number: APT-480-MV-120-420

AC power transducer, 480 VAC input, ProteCT™ current inputs, 120 VAC powered, 4–20 mA output, DIN rail mounting.

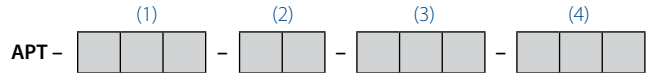

(1) Primary Voltage

| | |
|-----|---------|
| 120 | 120 VAC |
| 240 | 240 VAC |
| 480 | 480 VAC |
| 600 | 600 VAC |

(2) Current Input Type

| | |
|-----|---|
| MV | ProteCT™ current transformers, 333 mVAC secondary |
| 5 A | 5 A secondary current transformers |

(3) Power Supply

| | |
|-----|-----------|
| 24U | 24 VAC/DC |
| 120 | 120 VAC |
| 240 | 240 VAC |

(4) Output Type

| | |
|-----|---|
| 420 | 4–20 mA proportional to wattage (see calculation example under APT Output Values) |
| 005 | 0–5 VDC |
| 010 | 0–10 VDC |



Test & Evaluation Units for OEMs

Free program expedites evaluation process. See page 3 for details.



APT-TH SERIES

Power Transducers

The APT-TH Series Power Transducers monitor watt consumption of three phase loads. They provide an analog signal proportional to the active power consumed by the monitored load. The three current carrying conductors pass through the three windows of the top section and the matching voltage input at the terminals. The APT-TH is a one-piece solution for measuring power; no external current transformers are needed and installation is easy. The design of the APT-TH ensures that the monitor is always correctly orientated. If connected improperly by mismatching the current and voltage inputs, or placing a conductor through the sensing window back to front rather than front to back, the LED will change color from green to amber. The LED will also turn amber if the phase A conductor is placed through the phase B sensing window, or if power factor is lower than 0.50.

Power Transducer Applications

Pump Monitoring

- Monitor pumps to detect open intake or outflow lines, cavitation or failing bearings.

Grinding and Milling

- Measure wattage/horsepower to optimize feed rate.
- Detect broken or missing tools or drill bits.
- Detect when the tool contacts the material.

Equipment Monitoring

- Constant output proportional to wattage consumed can be compared with utility bills, providing a cost per hour or cost per operation of a machine or process.



Power Transducer Features

One-piece Solution

- No external current transformers.
- No chance for loose CT secondary provides added safety.

Easy Installation

- Snaps onto DIN rail or can be panel mounted using screws.

Finger Safe Terminals for Safety

LED Indicator

- LED on base shows correct phase relationship match.
- Green for normal operation.
- Orange for incorrect installation.

Three Ample Sensing Windows

- Wire carrying 200 A fits easily.

UL/cUL and CE Approved

- Accepted worldwide.

Power Transducer Connections

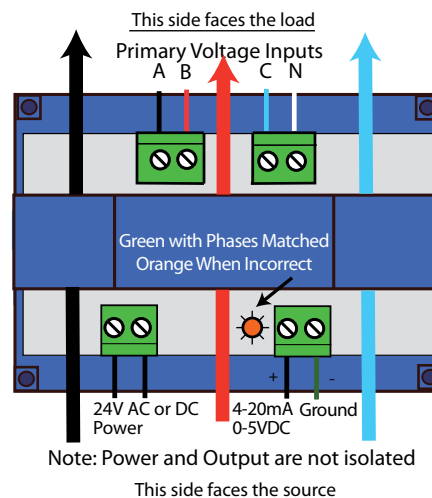

Submersible Pump Application

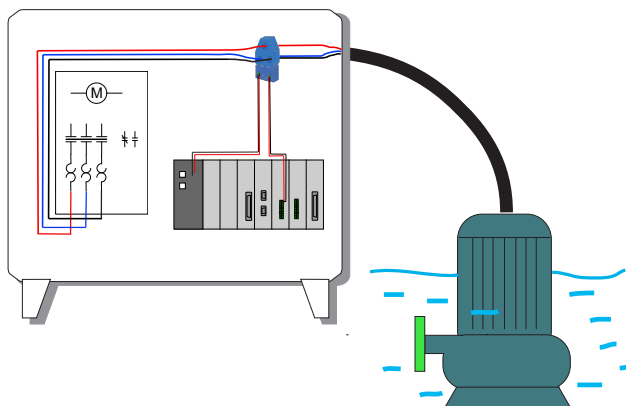

Power Sensing Products



APT-TH SERIES

792000026 Rev 1

Power Transducer Dimensions

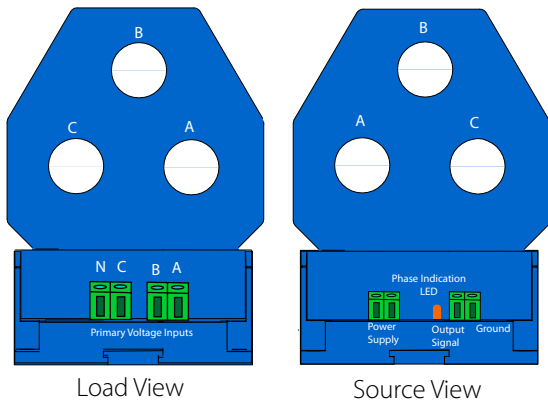
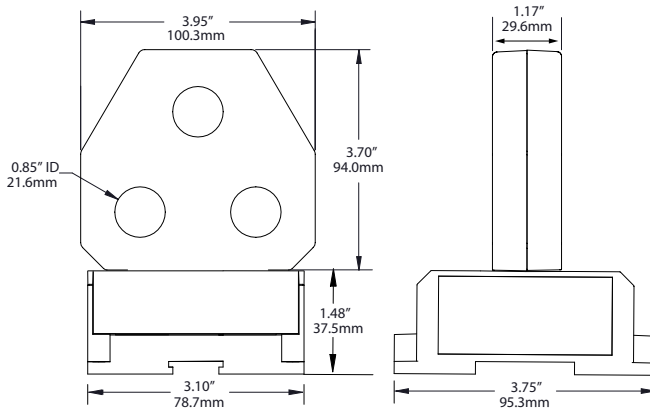

Model Information

| | APT1 (208 V) | APT2 (240 V) | APT4 (480 V) | APT6 (600 V) |
|---------|-----------------|-----------------|-----------------|-----------------|
| 0.5 kW | * | * | NA | NA |
| 0.75 kW | * | * | NA | NA |
| 1.00 kW | * | * | * | NA |
| 2.00 kW | * | * | * | * |
| 5.00 kW | * | * | * | * |
| 7.50 kW | * | * | * | * |
| 10.0 kW | * | * | * | * |
| 15.0 kW | * | * | * | * |
| 20.0 kW | * | * | * | * |
| 40.0 kW | * | * | * | * |
| 50.0 kW | * | * | * | * |
| 60.0 kW | * | * | * | * |
| 75.0 kW | * | * | * | * |
| 100 kW | NA | NA | * | * |
| 150 kW | NA | NA | * | * |
| 200 kW | NA | NA | NA | * |

Power Transducer Specifications



| | |
|------------------------------|---|
| Power Supply | 24 VAC or DC |
| Power Consumption | <4 VA |
| Primary Voltage Input | 208, 240, 480, 600 VAC |
| Output | 4–20 mA 0–5 VDC |
| Response Time | 500 ms (10–90% step change) |
| Accuracy | +/-1% FS |
| Frequency Range | 40–100 Hz |
| Case | UL94 V-0 Flammability Rated |
| Environmental | -4 to 122°F (-20 to 50°C) 0–95% RH, non-condensing |
| Listings | UL, cUL and CE |

Ordering Information

Sample Model Number: APT1-005-24U-10.0-TH, power transducer, 208 V, three-phase monitored voltage, output 0–5 VDC, 24 VAC/DC powered, 10.0 kW input range, three-hole, solid-core case.

(1) (2) (3) (4) (5)
APT [] - [] - **2 4 U** - [] - **T H**

(1) Monitored Voltage

| | |
|---|-------------------|
| 1 | 208 V three-phase |
| 2 | 240 V three-phase |
| 4 | 480 V three-phase |
| 6 | 600 V three-phase |

(2) Output Signal

| | |
|-----|---------|
| 420 | 4–20 mA |
| 005 | 0–5 VDC |

(3) Power Supply

| | |
|-----|-----------|
| 24U | 24 VAC/DC |
|-----|-----------|

(4) Input Range (kW)*

| | | | |
|------|------|------|------|
| 0.50 | 5.00 | 20.0 | 75.0 |
| 0.75 | 7.50 | 40.0 | 100 |
| 1.00 | 10.0 | 50.0 | 150 |
| 2.00 | 15.0 | 60.0 | 200 |

(5) Case

| | |
|----|------------------------|
| TH | Three-hole, solid-core |
|----|------------------------|

Note: Not all ranges are available for each primary voltage input range. See Model Information chart.

OEMs Test & Evaluation Units for OEMs
 Free program expedites evaluation process. See page 3 for details.

Signal Converters

NK Technologies' ADC series signal converters use sensor outputs (4–20 mA, 0–5 and 0–10 VDC) and convert these to digital RS485 outputs. The CTC series accept either 5 A secondary current from current transformers or 0.333 VAC secondary voltage from our ProteCT™ series sensors and converts it to 4–20 mA loop-powered output for use with PLCs, panel meters or data loggers.

Features:

- DIN rail mounting makes installation a snap
- Industry standard outputs

- **ADC SERIES**
Analog to Digital Converterpage 134
- **CTC SERIES**
Signal Converter.....page 136

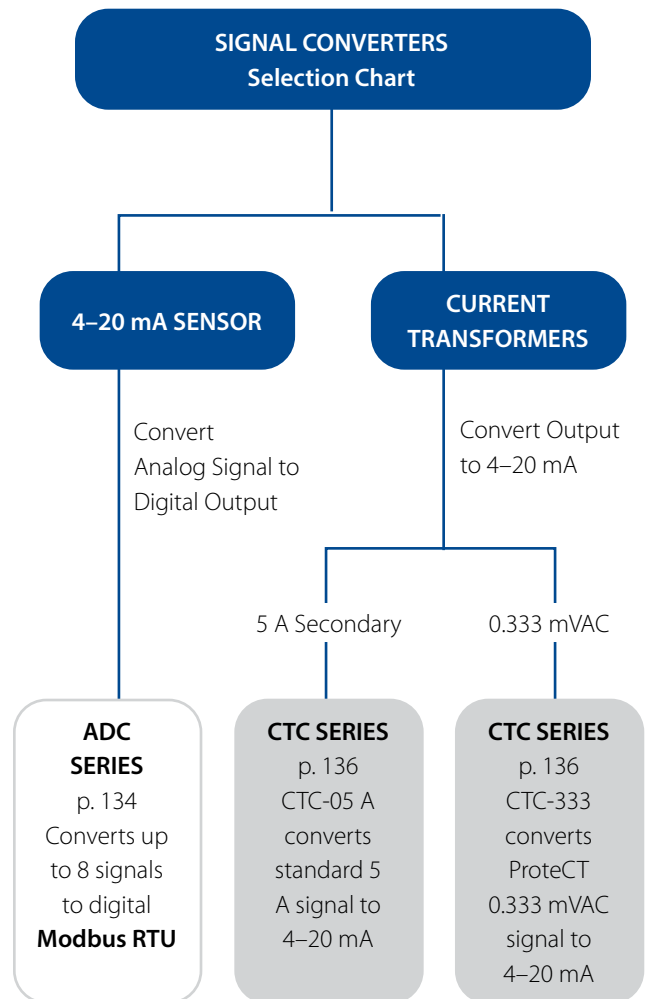

ADC SERIES

Analog to Digital Converters

The ADC Series Signal Converter connects up to eight analog sensors, or up to eight separately powered analog output sensors, or up to four of each. This will produce a digital signal representing 0–100% of each sensor output. It is the perfect solution for photovoltaic power production system monitoring. The ADC converter allows for individually-ranged devices to interface with the industry-standard **Modbus RTU** serial protocol. The device can accept analog signals from current, voltage or temperature sensors, allowing the installer great versatility and higher accuracy. It was designed and built to meet NK Technologies' trusted standards of reliability and ease of use.

Signal Converter Applications

Photovoltaic Power Production

- Measure current output accurately using a sensor sized appropriately.
- Measure current from a panel and after the combiner with the same device.
- Measure voltage output, temperature, or any parameter sensor 4–20 mA, 0–5 VDC or 0–10 VDC output.

Machine Control

- Combine several analog signals into a single **Modbus** address to enable web viewing of data.

SCADA System

- Report and record current, voltage, power, pressure, frequency and flow by using existing sensors but adding network communication easily.

Analog Sensor to Digital Network Conversion

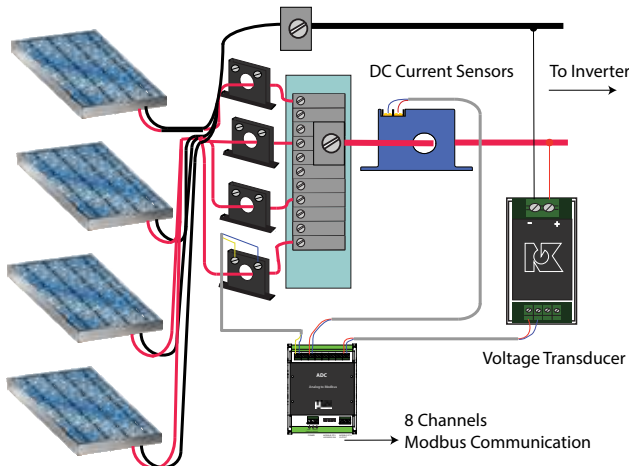

Signal Converter Features

Eight Points of Data

- Convert up to eight analog, sensor outputs using a single network address.
- Sensor loop power is supplied by the converter: No DC power supply is required.
- Models for 8 loop-powered (2-wire) and 8 externally powered (4-wire) or 4 of each type.

Fast and Easy Installation

- DIN rail mount converter* with finger-safe terminals clearly marked for field installation speed.

Application Versatility

- Convert any standard sensor output to **Modbus RTU** digital network format.

Choice of Power Supplies

- ADC converter can be factory set for 120 VAC, 240 VAC or 24 VDC power supplies.

Communication Baud Rate Choices

- Field-selectable 9600 or 19200 baud rate speeds.

UL/cUL Approved

- Accepted worldwide.

*For information on the DIN rail accessories kit, see page 147.

Use any 4–20 mA, 0–5 VDC or 0–10 VDC output sensor as an input to the NK Technologies' ADC analog-to-**Modbus** converter: Current, voltage, temperature, or any parameter that the application calls for. With the digital **Modbus** output scaled for zero to 100 percent the signal will represent whatever you may need to measure.

For additional Application Examples, go to www.nktechnologies.com/applications

Signal Converter Dimensions

Side View

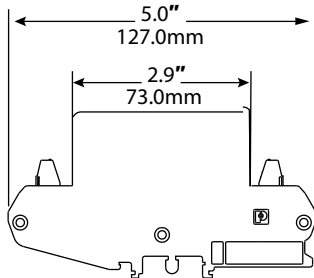

End View

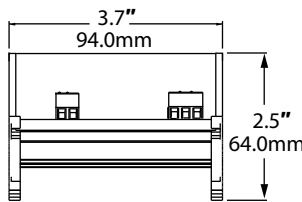

Signal Converter Connections

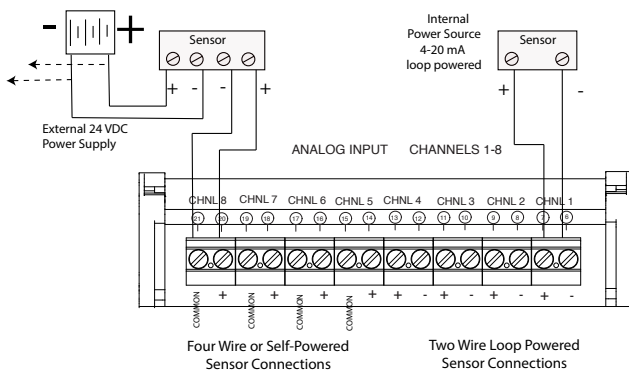

Signal Converter Specifications



| | |
|--------------------------|---|
| Power Supply | <ul style="list-style-type: none"> • 120 VAC (108–132 V) • 240 VAC (216–264 V) • 24 VDC (22–26 V) |
| Power Consumption | <ul style="list-style-type: none"> • 120 VAC: <50 mA • 240 VAC: <25 mA • 24 VDC: <200 mA |
| Output | Modbus RTU Slave 8 Channels (RS485) |
| Output Protocol | 1 start bit, 8 data bits (LSB first), 1 bit for even parity, 1 stop bit |
| Output Functions | Function 04, "Read Input Registers" |
| Output Range | 0–120% (4 mA = 0, 20 mA = 100%) |
| Input Range | <ul style="list-style-type: none"> • 4–20 mA (power from converter or external) • 0–5 VDC (externally powered) • 0–10 VDC (externally powered) |
| Accuracy | 1.0% FS |
| Indication | Green Power On LED, yellow Busy LED, red Fault LED |
| Addressing | 8 wide binary switch (1 to 247) |
| Environmental | -4 to 122°F (-20 to 50°C) 0–95% RH, non-condensing |
| Listings | UL/cUL |

Signal Converter Ordering Information

Sample Model Number: ADC1-420-120-MOD-DIN
Eight-channel 4–20 mA input converter, 120 VAC powered.

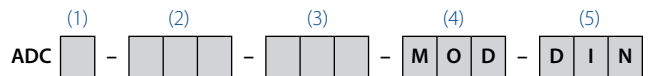

(1) Input channels

| | |
|---|---|
| 1 | Eight 4–20 mA loop-powered input channels |
| 2 | Four loop-powered, four external powered (4-wire) |
| 3 | Eight external-powered inputs |

(2) Sensor Input Type

| | |
|-----|------------------------------|
| 420 | 4–20 mA inputs |
| 005 | 0–5 VDC |
| 010 | 0–10 VDC as inputs available |

(4) Output Type

| | |
|-----|------------|
| MOD | Modbus RTU |
|-----|------------|

(5) Case Style

| | |
|-----|-------------------|
| DIN | DIN rail mounting |
|-----|-------------------|

(3) Power Supply

| | |
|-----|---------|
| 120 | 120 VAC |
| 240 | 240 VAC |
| 24D | 24 VDC |

Signal Converters



Test & Evaluation Units for OEMs

Free program expedites evaluation process. See page 3 for details.



CTC SERIES

Signal Converters

CTC Series Signal Converters allow you to use an existing standard 5 A secondary or low-voltage ProteCT™ current transformer over a conductor to produce an industry standard 4–20 mA two-wire, loop-powered signal. The signal is proportional to the current in the primary circuit. The CTC series snaps onto a standard DIN rail. The sensor output is connected to the load (PLC or panel meter, etc.) and a 24 VDC power source, and the current transformer is connected to the input terminals.



Signal Converter Applications

Adding Current Monitoring for System Upgrades

- Measure an entire plant current consumption or individual machine usage.

Detect Problems Before Failure Occur

- Detect bearing failures on drive motors and open discharge lines on pumps.

Tool Monitoring and Jam Protection

- Measure drive motor HP to determine tool travel or contact with work.
- Monitor motor current use to provide an indication of motor jams.
- Use existing current transformers to monitor the current, and transmit 4–20 mA industry standard output.

Signal Converter Features

Uses any Standard 5 A Current Transformer or the Safer ProteCT™ Low Voltage Design

- Produces a 4–20 mA signal proportional to the AC current through the CT based on CT ratio.
- Two wires in, two wires out: Couldn't be easier.

Fast and Easy Installation

- DIN rail mounted* and 24 VDC loop-powered supply allows for quick and easy two-wire installation.

No Calibration Needed

- The primary current transformer ratio provides the scaling required without any other installer intervention.

UL/cUL Approved

- Accepted worldwide.

*For information on the DIN rail accessories kit, see page 147.

Crusher/Grinder/Shredder Motor Interlocks

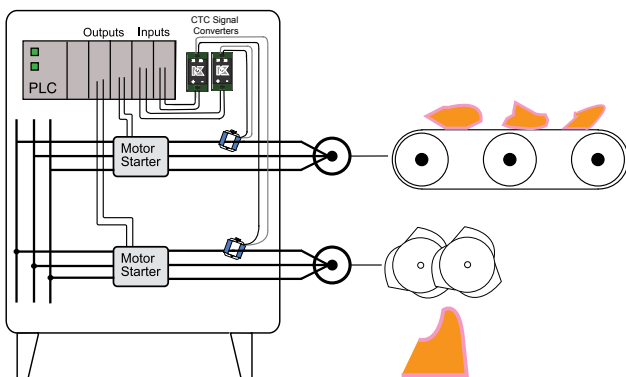

For additional Application Examples, go to www.nktechnologies.com/applications

Signal Converter Dimensions

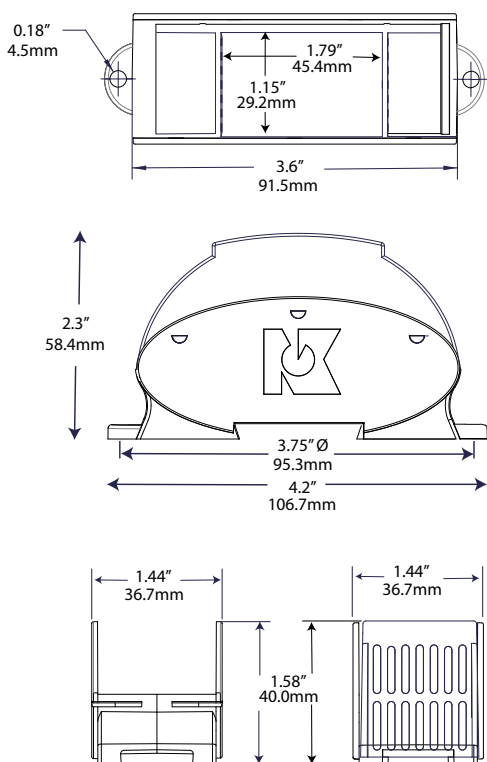

Signal Converter Connections

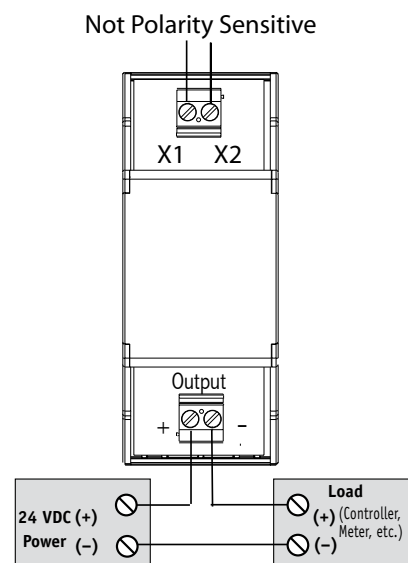

Notes:

With 5 A secondary current transformers, the secondary must be connected to a load (NK Technologies' CTC converter or other load) when energized.

With ProteCT™ type (low voltage output) current sensors, there is no chance that dangerous voltages will result if the secondary is open when there is current through the sensing window.

Signal Converter Specifications



| | |
|----------------------------|---|
| Power Supply | 24 VDC loop-powered (12–30 V) |
| Output | 4–20 mA proportional to max. current |
| Output Impedance | <500Ω |
| Input Range | Based on current sensor ratio |
| Input Burden | 1.67 VA max. for stated accuracy |
| Accuracy | 1.0% FS |
| Response Time | 100 ms (to 90% step change) |
| Max. Inrush Current | 300% FS (6 sec. duration) |
| Frequency Range | 10–100 Hz |
| Environmental | -4 to 122°F (-20 to 50°C) 0–95% RH, non-condensing |
| Listings | UL/cUL |

Signal Converter Ordering Information

Sample Model Number: CTC333-420-24L-DIN
 Converter accepts 333 VAC inputs from ProteCT™ current sensors, and produces a corresponding 4–20 mA signal.

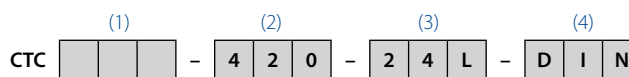

(1) Input CT Type

| | |
|------|--------------------------------|
| 333 | 0.333 VAC low voltage ProteCT™ |
| 05 A | 5 A secondary |

(2) Output Signal

| | |
|-----|---------|
| 420 | 4–20 mA |
|-----|---------|

(3) Power Supply

| | |
|-----|---------------------|
| 24L | 24 VDC loop-powered |
|-----|---------------------|

(4) Case Style

| | |
|-----|-------------------|
| DIN | DIN rail mounting |
|-----|-------------------|

Signal Converters

OEMs Test & Evaluation Units for OEMs
 Free program expedites evaluation process. See page 3 for details.



Current Transformers

NK Technologies offers current transformers (CTs) for use with power transducers, panel meters, and in two-piece installations, with transducers and switches to extend ranges for high amperage/large conductor applications.

Features:

- 1 A, 5 A or 0–333 mV secondary outputs
- Split-core or solid-core case
- Agency approved
- 5 A secondary ratios available from 50 A to 3000 A and higher

- **CT-MS & CT-LS Series**
1 A & 5 A Secondary Current Transformerspage 139
- **Current Transformers**
5 A Secondary.....page 141
- **CTRC Series**
AC Current Transformer
ProteCT Type 333 mVAC Output.....page 143
- **ProteCT™ Series**
mV Current Transformers.....page 145

CT-MS & CT-LS SERIES

1 A & 5 A Secondary Current Transformers

1 A and 5 A Secondary Current Transformers offer a compact, cost-effective means of measuring primary current. These current transformers provide an easy-to-install method to measure AC current, producing a 0–1 A or 0–5 A output proportional to the current flowing through the sensing window. Both the CT-MS and the CT-LS series offer a larger-than-average sensing window and a split-core design for easy installation.

Current Transformer Features

- Split-core case for convenient installation over large wires or bus bars.
- 1 A and 5 A secondary CTs are compatible with standard power monitors and panel meters designed for 1 A or 5 A input.
- Larger sensing windows:
MS Series aperture measures 2.22" x 1.19" and measures current from 0–150 to 0–800 A.
LS Series aperture measures 3.44" x 2.32" and measures current from 0–800 to 0–1400 A.
- Plated terminals for reliability.
- UR recognized file E475131. Meets ANSI/IEEE C57.13 and IEEE C57.13.2.

Current Transformer Applications

- Serves as current input for use with APT and APN series KW transducers.
- Saves space in control panels by remotely locating the sensing of the current closer to the load.
- The current transformer secondary can be connected to the NK CTC-05A-420-24L-DIN to produce a loop-powered, 4–20 mA signal proportional to the current through the CT.

Power-Pump Load Monitoring

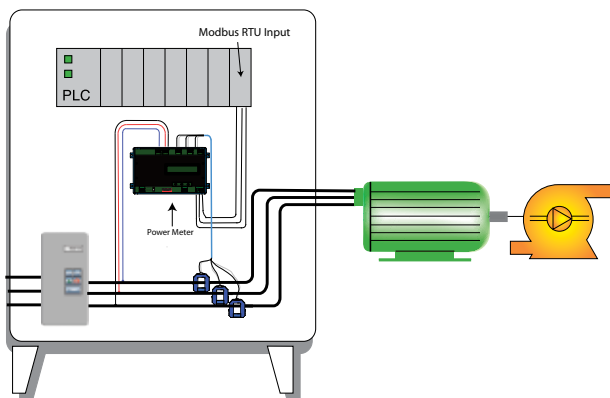

CT-MS Series



CT-LS Series

Connecting a Current Transformer

A current transformer (CT) should never be energized (AC current through the sensing window) without a load connected to the output terminals. Best practice is to terminate the current transformer secondary on a terminal block with the ability to short between two points before extending the leads to the load. If it is ever necessary to remove the load from the CT while it is or could become energized, a shorting bar can be placed between the secondary loads, as shown in the drawing below. This will allow the load to be removed safely.

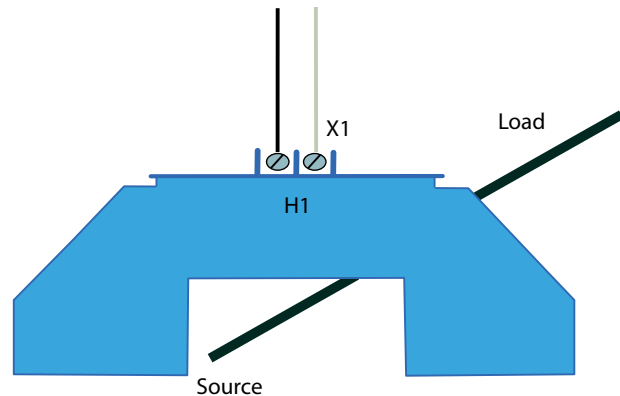

Current Transformers

OEMs

Test & Evaluation Units for OEMs

Free program expedites evaluation process. See page 3 for details.



CT-MS & CT-LS SERIES

292000115 Rev 2

Current Transformer Dimensions

CT-MS

6-32 COMBO SCREWS

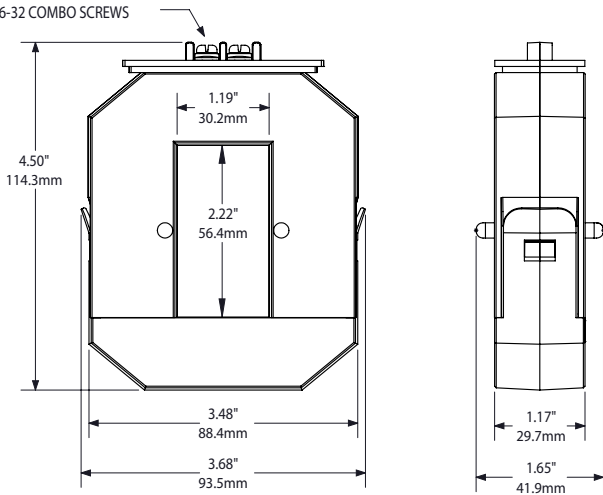

CT-LS

6-32 COMBO SCREWS

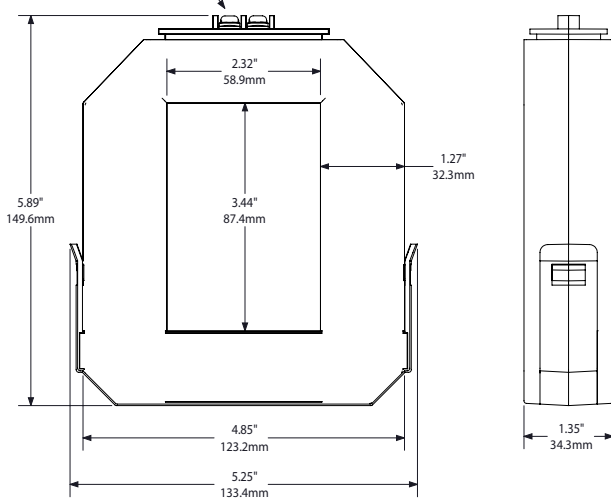

Current Transformer Connections

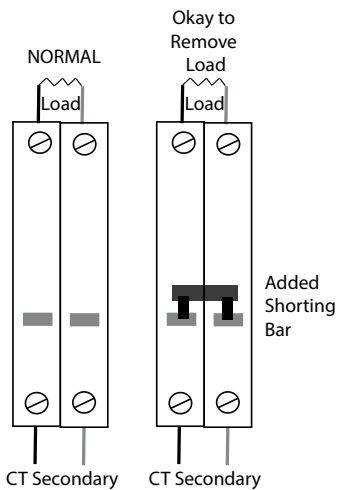

Current Transformer Specifications



| | | | | | | | | |
|--------------------------------|--|------------|---------------|----------|---------------|---------|---------------|---------|
| Power Supply | None, self-powered | | | | | | | |
| Current Range | <ul style="list-style-type: none"> • CT-MS: 0–150 through 0–800 A • CT-LS: 0–800 through 0–1400 A | | | | | | | |
| Output Signal | 0–1 A or 0–5 A (AC) | | | | | | | |
| Frequency | 50/60 Hz | | | | | | | |
| Primary Circuit Voltage | 600 VAC | | | | | | | |
| Accuracy | <ul style="list-style-type: none"> • 0–1400 A models: ±1% (10–100% of range) to 50°C • 150 A model: ±1.5% (10–100% of range) to 50°C | | | | | | | |
| Linearity | 0.5% (10–100% of range) | | | | | | | |
| Thermal Rating | 1.0 @ 30°C | | | | | | | |
| Listings | UR/cUR, CE | | | | | | | |
| Weight | CT-MS Series | | CT-LS Series | | | | | |
| | 150 | <0.75 lbs. | 800 | 2.0 lbs. | | | | |
| | 200 | <0.75 lbs. | 1000 | 2.2 lbs. | | | | |
| | 300 | <0.75 lbs. | 1200 | 2.3 lbs. | | | | |
| | 400 | <0.75 lbs. | 1400 | 2.3 lbs. | | | | |
| | 500 | <0.75 lbs. | | | | | | |
| | 600 | <0.75 lbs. | | | | | | |
| | 800 | <0.75 lbs. | | | | | | |
| Allowable Burden | CT-MS Series | | CT-LS Series | | | | | |
| | 1 A Secondary | | 5 A Secondary | | 1 A Secondary | | 5 A Secondary | |
| | Ratio | Burden | Ratio | Burden | Ratio | Burden | Ratio | Burden |
| | 150:1 | 1.0 VA | 150:5 | 1.2 VA | 800:1 | 16.0 VA | 800:5 | 10.0 VA |
| | 200:1 | 1.0 VA | 200:5 | 1.2 VA | 1000:1 | 16.0 VA | 1000:5 | 10.0 VA |
| | 300:1 | 1.0 VA | 300:5 | 1.2 VA | 1200:1 | 16.0 VA | 1200:5 | 10.0 VA |
| | 400:1 | 1.0 VA | 400:5 | 1.2 VA | 1400:1 | 16.0 VA | | |
| | 500:1 | 2.0 VA | 500:5 | 5.0 VA | | | | |
| | 600:1 | 2.0 VA | 600:5 | 7.5 VA | | | | |
| | 800:1 | 2.0 VA | 800:5 | 7.5 VA | | | | |

Current Transformer Ordering Information

Sample Model Number: CT-0800-5-LS

Current transformer with 800:5 ratio allowable burden, 5 A secondary output, and large sensing window.



(1) Model

| CT-MS Models | |
|--------------|-----------|
| 0150 | 150 ratio |
| 0200 | 200 ratio |
| 0300 | 300 ratio |
| 0400 | 400 ratio |
| 0500 | 500 ratio |
| 0600 | 600 ratio |
| 0800 | 800 ratio |

| CT-LS Models | |
|--------------|-----------------------|
| 0800 | 800 ratio |
| 1000 | 1000 ratio |
| 1200 | 1200 ratio |
| 1400 | 1400 ratio (1 A only) |

(2) Output Signal

| | |
|---|-----------------|
| 1 | 0–1 A secondary |
| 5 | 0–5 A secondary |

(3) Case Style

| | |
|----|-----------------------|
| MS | Medium sensing window |
| LS | Large sensing window |



Test & Evaluation Units for OEMs

Free program expedites evaluation process. See page 3 for details.



3511 Charter Park Drive • San Jose, CA 95136
800.959.4014 • www.nktechnologies.com • sales@nktechnologies.com



CURRENT TRANSFORMERS

5 A Secondary

5 A Secondary Current Transformers offer a compact, cost-effective means of measuring primary current and providing 0–5 A secondary output proportional to the primary current being sensed. Available in a solid-core case.



Current Transformer Features

- Solid-core case; choice of round with flying leads or square with terminals and integral feet for panel mounting.
- Aperture diameters from 1.13" to 2.5" ID.
- Agency approved.

Current Transformer Applications

- Serves as current input for use with APT and APN Series KW transducers.
- Save space in control panels by remotely locating CTs closer to load.
- 5 A secondary compatible with standard products offering a 5 A analog input option.
- Broad line accommodates primary currents from 50 A to 1600 A.

Current Transformer Specifications

| | | |
|-------------------------|-----------------------------|----------------------|
| Power Supply | None, Self-powered | |
| Current Range | See Ranges/VA Burdens | |
| Output Signal | 0–5 A (AC) | |
| Frequency Range | 50–400 Hz | |
| Insulation Class | 0.6 KV BIL, 10 KV full wave | |
| Accuracy | ANSI rated, (<2.0%) | |
| Allowable Burden | See Ranges/VA Burdens | |
| Rating Factor | 2.0 @ 30°C amb. | |
| Sensing Aperture | Series | Aperture Size |
| | 2 | 1.13" (28.7 mm) |
| | 5 | 1.56" (39.6 mm) |
| | 7 | 2.50" (63.5 mm) |

Current Transformer Ranges/VA Burdens (max.)

| VA (by CT Series) | | | Model | CT Ratio:5 |
|-------------------|------|------|-------|------------|
| 2 | 5 | 7 | | |
| 1 | 0.75 | 0.5 | 500 | 50 |
| 2 | 1.25 | 1 | 750 | 75 |
| 2.5 | 2.25 | 2 | 101 | 100 |
| 4 | 5 | 2.5 | 151 | 150 |
| 5 | 5 | 5 | 201 | 200 |
| 7.5 | 10 | 5 | 251 | 250 |
| 10 | 12.5 | 5 | 301 | 300 |
| | 12.5 | 12.5 | 401 | 400 |
| | 25 | 15 | 501 | 500 |
| | 25 | 25 | 601 | 600 |
| | 30 | 35 | 801 | 800 |
| | 35 | 35 | 102 | 1000 |
| | 40 | 40 | 122 | 1200 |
| | | 50 | 152 | 1500 |
| | | 50 | 162 | 1600 |

Note: For recommended lead length based on allowable burden, see the CT White Paper.

Current Transformer Ordering Information

Sample Model Number: 5RL501-NK

Current transformer with 1.56" aperture, round doughnut case, and 500:5 ratio.

(1) (2) (3)

5 R L 5 0 1 - NK

(1) Series

2, 5, or 7 CT Series

(2) Case

RL Round doughnut

SFT Square, integral mounting feet

(3) Model

XXX See Ranges/VA Burdens



Test & Evaluation Units for OEMs

Free program expedites evaluation process. See page 3 for details.



CURRENT TRANSFORMERS

894080003 Rev 2

Current Transformer Dimensions

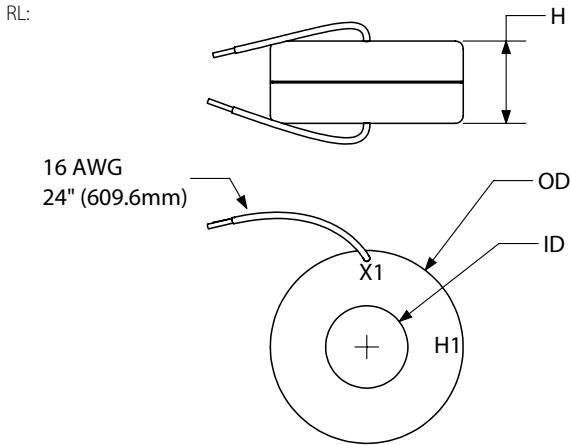

| | 2RL | 5RL | 7RL |
|----|----------------|----------------|-----------------|
| OD | 2.46" (62.5mm) | 3.56" (90.4mm) | 4.71" (119.6mm) |
| ID | 1.05" (26.7mm) | 1.56" (39.6mm) | 2.50" (63.5mm) |
| H | 1.05" (26.7mm) | 1.10" (27.9mm) | 1.12" (28.5mm) |

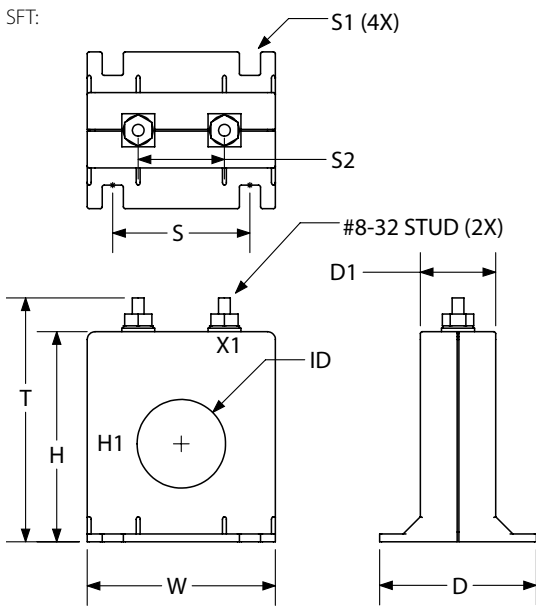

| | 2SFT | 5SFT | 7SFT |
|----|-------------------------------|-------------------------------|-------------------------------|
| W | 2.40" (61.0mm) | 3.53" (89.7mm) | 4.54" (115.3mm) |
| T | 3.11" (79.0mm) | 4.22" (107.2mm) | 5.28" (134.1mm) |
| H | 2.68" (68.1mm) | 3.79" (96.3mm) | 4.85" (123.2mm) |
| S | 1.75" (44.5mm) | 2.74" (69.6mm) | 3.76" (95.5mm) |
| S1 | 0.27 x 0.30" (6.9 x 7.6mm) | 0.23 x 0.31" (5.8 x 7.9mm) | 0.23 x 0.31" (5.8 x 7.9mm) |
| S2 | 1.10" (27.9mm) | 3.00" (76.2mm) | 3.50" (88.9mm) |
| D | 2.00" (50.8mm) | 2.15" (54.6mm) | 2.15" (54.6mm) |
| D1 | 0.96" (24.4mm) | 1.10" (27.9mm) | 1.10" (27.9mm) |
| ID | 1.13" (28.7mm) | 1.56" (39.6mm) | 2.50" (63.5mm) |

OEMs

Test & Evaluation Units for OEMs

Free program expedites evaluation process. See page 3 for details.

CTRC SERIES

ProteCT™ Type 333 mVAC Output

CTRC AC Current Transducer monitor circuits up to 2000 A and produce a safe, low voltage output proportional to the RMS current value. This output is designed as an input to a power monitor or transducer, replicating the AC wave shape with phase angle resolution better than 2 degrees. The flexible coil design allows the sensor to be installed over multiple conductors or bus assemblies easily. The cable requires very little space to fit between adjacent phase conductors. The design eliminates the magnetically permeable core of standard current transformers while providing excellent isolation, sensing only the magnetic field of the phase inside the loop.



Current Transducer Applications

Power Monitoring

- Accurate representation of current without the weight or hazards created by 5 A secondary current transformers.

Individual Machines

- Measure power use for cost allocation.
- Detect voltage sags and spikes.

Monitor Entire Building Power Usage

- Locate unneeded power consumption.

Monitoring Power Usage of a Motor Driven Pump

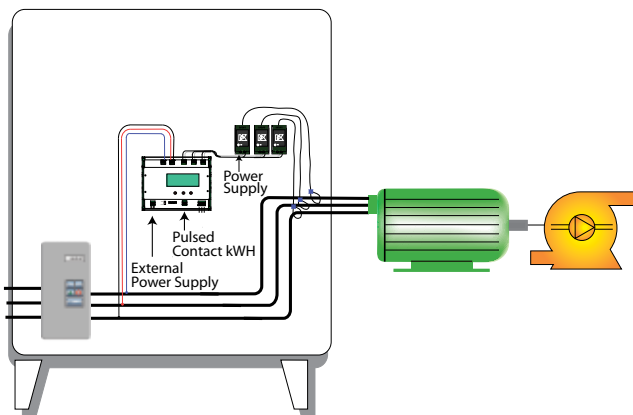

Current Transducer Features

333 mVAC Output

- Specifically designed for connection to power monitors and transducers.
- Safe, with no need for shorting blocks.

24 VAC or VDC Powered

- Supply and Output are optically isolated.

Factory Calibrated

- Reduces field calibration errors.
- Coils matched with signal conditioning.

DIN Rail Mounted Case*

- Compact size requiring very little panel space.
- Simple snap fit to standard rails.

UL/cUL and CE Approved

- Accepted worldwide.

*For information on the DIN rail accessories kit, see page 147.

- For additional Application Examples, go to www.nktechnologies.com/applications

OEMs Test & Evaluation Units for OEMs
Free program expedites evaluation process. See page 3 for details.



CTRC SERIES

291180005 Rev 2

AC Current Transducer Dimensions

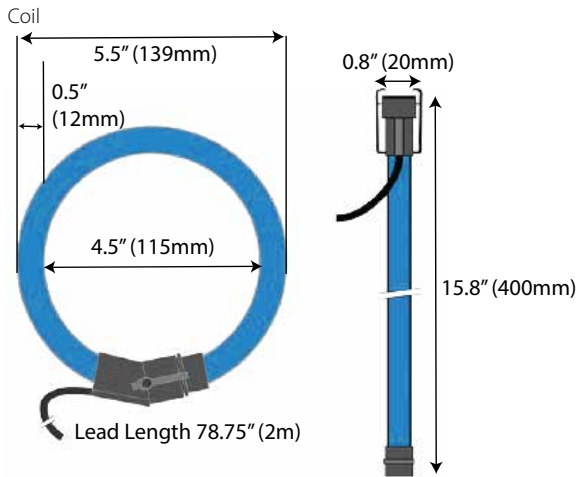
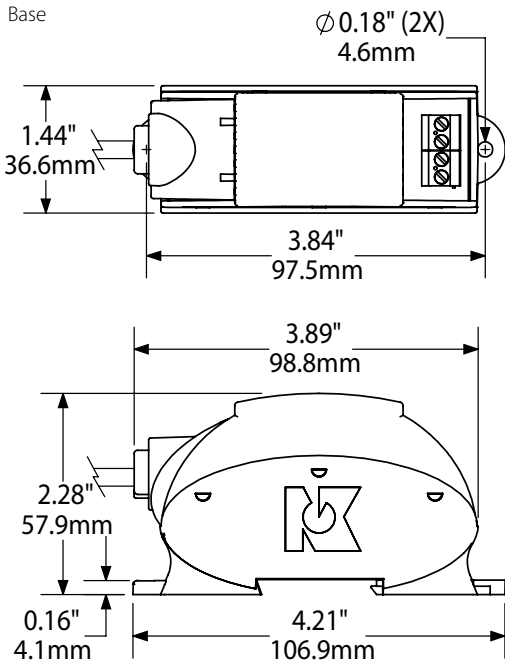

Current Transducer Connections

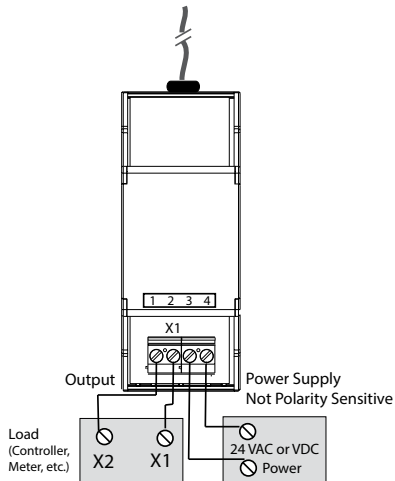

Current Transducer Specifications



| | |
|--------------------------|--|
| Power Supply | 24 VAC/VDC (12–36 V) |
| Power Consumption | <2 VA |
| Output Signal | 333 mVAC |
| Response Time | 2 ms |
| Input Range | <ul style="list-style-type: none"> • 0–300 • 0–500 • 0–1000 • 0–1500 • 0–2000 |
| Accuracy | ±1% FS |
| Output Loading | 100 KΩ minimum for accuracy |
| Isolation Voltage | Tested to 3.5 KV |
| Frequency Range | 40–400 Hz |
| Sensing Aperture | 4.5" (115 mm) ID |
| Environmental | -4 to 122°F (-20 to 50°C) 0–95% RH, non-condensing |
| Listings | UL/cUL, CE |

Current Transducer Ordering Information

Sample Model Number: CTRC-333-500-24U-D
Flexible loop current sensor, 0–500 A AC produces 0–333 mVAC, DIN rail mounting case.

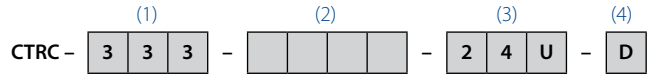

(1) Output Type

| | |
|-----|----------|
| 333 | 333 mVAC |
|-----|----------|

(2) Full Scale Range

| | |
|------|-----------|
| 300 | 300 A AC |
| 500 | 500 A AC |
| 1000 | 1000 A AC |
| 1500 | 1500 A AC |
| 2000 | 2000 A AC |

(3) Power Supply

| | |
|-----|---------------|
| 24U | 24 VAC or VDC |
|-----|---------------|

(4) Case Style

| | |
|---|-------------------|
| D | DIN rail mounting |
|---|-------------------|

ProteCT™ SERIES

mV Current Transformers

ProteCT™ Series Current Transformers are intended for use with APT and APN Series power transducers. ProtectCT™ low voltage output current transformers provide easy sensing of current on three-phase applications with the added safety of a 333 mV output secondary. Available in split-core case as standard.



Current Transformer Applications

- Tailored for use with AP Series AutoPhase KW/KWH transducers.
- Self-powered design works well in data logger applications.
- Excellent response time for power monitoring applications.

Current Transformer Features

0.333 VAC Output Secondary

- Unique low voltage output allows safe opening of transformer secondary, protecting installers from shock hazards found on traditional 5 A CTs.

Eliminates Need for “Shorting Blocks”

Standard Split-core Case Design

- Snap-close case speeds installation and eases retrofits for existing jobs.
- Eliminates need to power down or disconnect system to install CT, maximizing up time.

High-Impact, UL94 V-0 Rated Polymer Housing

- No exposed metal parts on assembled ProteCT™ devices.

Choose From Three ID's: 0.85", 1.25", 2.0"

Monitor Watts Used by a Pump

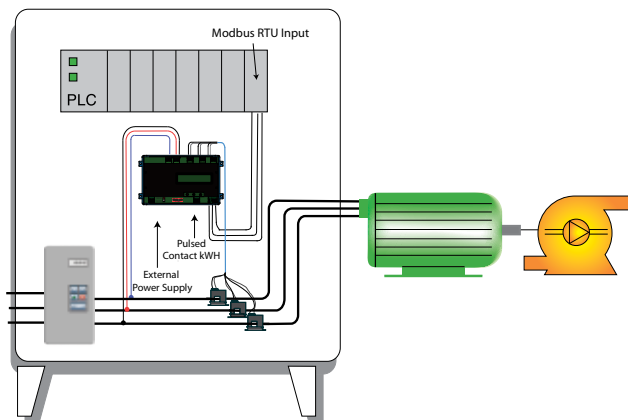

- For additional Application Examples, go to www.nktechnologies.com/applications

OEMs

Test & Evaluation Units for OEMs

Free program expedites evaluation process. See page 3 for details.

Current Transformer Dimensions

| in (mm) | NKP-075-xxx | CTP-125-xxx-SP | CTP-200-xxx-SP |
|---------------|-------------|----------------|----------------|
| Width | 2.25 (57.2) | 3.25 (82.55) | 4.75 (120.65) |
| Height | 2.40 (61.0) | 3.35 (85.09) | 5.00 (122.5) |
| Depth | 1.18 (30.0) | 1.00 (25.4) | 1.20 (30.48) |
| Window | 0.85 (22.0) | 1.25 (31.75) | 2.00 (50.80) |

Current Transformer Specifications

| | |
|-----------------------------|---|
| Power Required | None, self-powered |
| Accuracy | ±1% NKP, ±2% CTP models |
| Output Signal | 0–0.333 VAC |
| Phase Angle | <1 degree, 2 degrees @ 50% range |
| Response Time | <1 ms |
| Isolation Voltage | 3 KV |
| Max. Primary Voltage | 5000 VAC (insulated conductor) |
| Max. Inrush Current | 300% FS (6 sec. duration) |
| Environmental | -4 to 122°F (-20 to 50°C) 0–95% RH, non-condensing |

Current Transformer Ordering Information

| Model | Input Range | 1.25" (31.75 mm) Window | |
|-----------------------------|-------------|------------------------------|----------|
| 0.85" (22 mm) Window | | CTP-125-101-SP | 0–100 A |
| NKP-075-005SP | 0–5 A | CTP-125-151-SP | 0–150 A |
| NKP-075-015SP | 0–15 A | CTP-125-201-SP | 0–200 A |
| NKP-075-030SP | 0–30 A | CTP-125-251-SP | 0–250 A |
| NKP-075-050SP | 0–50 A | CTP-125-301-SP | 0–300 A |
| NKP-075-070SP | 0–70 A | CTP-125-401-SP | 0–400 A |
| NKP-075-101SP | 0–100 A | CTP-125-601-SP | 0–600 A |
| NKP-075-151SP | 0–150 A | 2.0" (50.8 mm) Window | |
| NKP-075-201SP | 0–200 A | CTP-200-601-SP | 0–600 A |
| | | CTP-200-801-SP | 0–800 A |
| | | CTP-200-102-SP | 0–1000 A |
| | | CTP-200-122-SP | 0–1200 A |
| | | CTP-200-152-SP | 0–1500 A |



AMPFlasher™ ACI SERIES

AC Current Indicators

The AMPFlasher™ ACI Series Current Indicator is a compact, inexpensive, easy-to-use LED ring which slips onto a conductor to give a flashing indication of current flow. Ideal for use in control panels, or wherever confirmation of current flow is desired. AMPFlasher™ current indicators are a cost-effective way to detect live conductors and see current flow to fans, heaters, pumps, lighting or other powered devices.

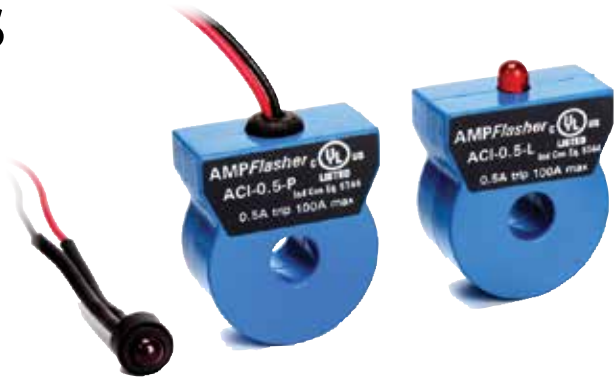

AC Current Indicator Applications

- Quick visual status of electric motor load.
- Identify open heater circuit connection.
- Provide panel mounted indication of current draw on monitored load.
- Confirmation of operation for critical lighting or equipment.

AC Current Indicator Features

Low Sensitivity Turn-on Point

- Detect currents as low as 0.5 A with a single conductor pass, eliminates the need to wrap conductors through multiple times to increase sensitivity.

High Visibility Flashing LED

- Flashing LEDs perform better in daylight conditions and from multiple angles than constant on LEDs.

Choice of Outputs

- LED output standard, optional LED on 24" pigtails for remote indication.

AC Current Indicator Dimensions

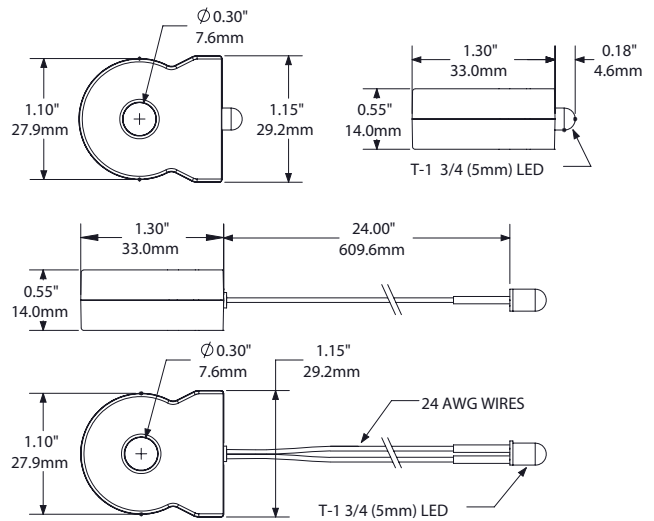

Note: Panel opening should be 0.250", panel thickness 0.032"

AC Current Indicator Specifications



| | |
|--|--|
| Output/Indication | • Standard: LED (flashing, red) • Optional: 24" Pigtails for Remote LED |
| Indicating Range | 0.5 A–100 A |
| LED On | <500 mA (factory set) |
| Maximum Primary Circuit Voltage | 300 VAC |
| Dimensions | • Overall: 1.15"W x 0.55"D x 1.30"H (29.2 mm W x 14.0 mm D x 33.0 mm H) • Aperture: 0.30" (7.6 mm) ID • Pigtails: 24" (609.6 mm) |
| Case | UL94 V-0 Flammability Rated |
| Mounting | Slides directly onto monitored conductor |
| Environmental | -4 to 122°F (-20 to 50°C) 0–95% RH, non-condensing |
| Frequency Response | 50–400 Hz |
| Listings | UL/cUL, CE |

AC Current Indicator Ordering Information

Sample Model Number: ACI-0.5-L.
Current Indicator with 0.5 A sensitivity and red flashing LED.

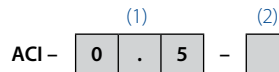

(1) Sensitivity Level

| | |
|-----|--------|
| 0.5 | 500 mA |
|-----|--------|

(2) Indication/Output

| | |
|---|-----------------------------|
| L | LED (flashing, red) |
| P | 24" Pigtails for remote LED |

OEMs Test & Evaluation Units for OEMs
Free program expedites evaluation process. See page 3 for details.

DIN RAIL KITS

DIN Kit or DIN-2 Adapter Kit

DIN Rail Kits provide a convenient method to facilitate the mounting of NK Technologies' products that can be DIN rail mounted. The kits can also be used to mount other products to a panel as needed.

DIN Rail Kit Features

DIN Rail Kit

- Includes two end stops and a bichromated galvanized steel rail.
- High mechanical strength and corrosion resistance.
- Slotted design allows for attachment to most suitable surfaces.
- Rail can be cut in field to desired length.



AGL Ground Fault Sensor

DIN Rail Kit Specifications

DIN Rail Kit

| | |
|----------------------|--|
| Rail Material | Rail is galvanized steel; 35 mm x 7.5 mm x 175 mm |
| Rating | Conforms to EN50035, 50022, DIN 46277 |

DIN-2 Adapter Kit

| | |
|---------------------------|--|
| Rail Compatibility | "Top Hat" Type: 35 x 15 mm, 35 x 7.5 mm "G" Type 32 x 15 mm |
| Bracket Material | UL94V-0 unfilled nylon |
| Temp Range | -4 to 122°F (-20 to 50°C) |

DIN-2 Adapter Kit

- Includes two plastic brackets and attachment screw to mount the sensor to the rail.
- Compatible with "top hat" or "G" type rail.

"Top Hat" type rail.



"G" type rail.

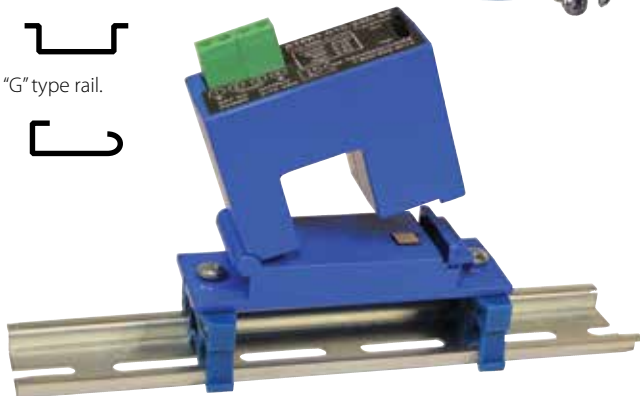

ATPR with DIN-2 Adapter Kit

DIN Rail Kit Ordering Information

Part Number for DIN Rail Kit: DINKIT

Part Number for DIN-2 Adapter Kit: DIN-2

OEMs

Test & Evaluation Units for OEMs

Free program expedites evaluation process. See page 3 for details.



ROHS 3 CERTIFICATE OF COMPLIANCE

Directive 2011/65/EU on the Restriction of Hazardous Substances



NK Technologies RoHS status is based on information provided by our raw material manufacturer's stated compliance to 2011/65/EU European Union Directive and amendment (EU) 2015/863, which adds 4 phthalates to 2011/65/EU as of July 22, 2019. NK Technologies RoHS status may include an allowable exemption as defined in the EU Directive 2011/65/EC and relevant amendments.

Based on the information provided to us by the suppliers of raw materials used in the manufacture and delivery of our products, NK Technologies maintains a list of specific model numbers and product families designated as RoHS 3 Compliant for orders placed on or after October 1, 2006.

The products listed conform to European Commission Directive 2015/863/EU as July 1, 2019 and does not intentionally contain more than the allowed maximum limit.

| Substance | Maximum Limit (ppm) |
|---|--------------------------|
| Lead (Pb) 1 | 1000 ppm (0.1 weight %) |
| Cadmium (Cd) 2 | 100* ppm (0.01 weight %) |
| Mercury (Hg) 1 | 1000 ppm (0.1 weight %) |
| Hexavalent Chromium (Cr+6) 1 | 1000 ppm (0.1 weight %) |
| Polybrominate biphenyls (PBBs) 1 | 1000 ppm (0.1 weight %) |
| Polybrominate biphenyl ethers (PBDEs) 1 | 1000 ppm (0.1 weight %) |
| Bis(2-Ethylhexyl) phthalate (DEHP) | 1000 ppm (0.1 weight %) |
| Benzyl butyl phthalate (BBP) | 1000 ppm (0.1 weight %) |
| Dibutyl phthalate (DBP) | 1000 ppm (0.1 weight %) |
| Diisobutyl phthalate (DIBP) | 1000 ppm (0.1 weight %) |

**Except when allowed by the Directive. For example, 3500 ppm in steel, 4000 ppm in aluminum alloys and 40000 ppm in copper alloys*

RoHS 3 Compliance shall be taken to mean that,

- With regard to existing designs, RoHS 3 certified substitutions for all materials and components have been specified.
- Components used in the production of compliant parts are certified RoHS 3 compliant and our suppliers have confirmed this compliance status.
- Soldering operations involved in the production of compliant products are performed using lead-free solder.

NK Technologies is committed to ensuring the health, safety and well-being of our employees, customers and the environment worldwide and we will continue to practice these principles in our global business.

Ron Rapczynski
Quality and Environmental Systems Manager

ISO 9001 AND ISO 14001 REGISTRATIONS

NK Technologies' commitment to quality and the environment goes beyond compliance to international standards. We have developed and implemented an integrated quality and environmental management system to ensure our business and manufacturing processes provide customer confidence and satisfaction while being good stewards of our environment.

The foundation of our consolidated system is based on the ISO 9001 and ISO 14001 standards. However we go above and beyond basic compliance to continuously improve all of our quality and environmental related operations. Our unwavering goal is to always achieve customer satisfaction with everything we do.

As an ISO registered organization our customers can buy with confidence knowing that NK Technologies designs and manufactures its products within a formal quality assurance system periodically audited by an independent third party auditor. Engaging an appropriately ANAB accredited auditor ensures we do not deviate from documented procedures that provide objective evidence of compliance to the ISO standards.



Please visit our website for more information about our Quality Standards and ISO 9001 Certification @ www.nktechnologies.com/quality-policy.html

TERMS AND CONDITIONS OF SALE

All quotes, offers of products for sale and sales by Neilsen-Kuljian, Inc. (sometimes also doing business as NK Technologies) or its affiliates are subject to these terms and conditions.

The term "Neilsen-Kuljian, Inc." may hereinafter be referred to as "NK Technologies" or the "Company" or "we" or "us" or "our" or "Seller" and the term "Buyer" or "Customer" or "you" or "your" hereinafter refers to the customer purchasing from Neilsen-Kuljian, Inc.

1. PRICE AND DELIVERY: All prices quoted, and deliveries made, will be "EXWORKS (EXW)" or "Free On Board (FOB)" from our factory located in San Jose, California, United States of America. Delivery shall be established by mutual agreement or as determined by NK Technologies. All orders are subject to a minimum order amount of One Hundred U.S. Dollars (\$100) in total. Drop shipments can be arranged as needed and may incur additional handling fees.

2. ALL SALES ARE FINAL: Unless otherwise agreed in writing by the Company, all sales of products by NK Technologies become final, non-cancelable, non-returnable and non-refundable at the time an order is confirmed by the Company. Return of products categorized as "NCR", non-cancelable or non-returnable or those made with non-standard material or other material provided specially to meet Buyer's specifications shall not be cancelable or returnable for any reason including Company delay or lead times.

3. CONFLICTING OR MODIFYING TERMS: No modification of, additions to or conflicting provisions to these terms and conditions of sale and shipment, whether oral or written, incorporated into Buyer's order or other communications are binding upon the Company unless specifically agreed to by the Company in writing and signed by an officer of the Company. Failure of the Company to object to such additions, conflicts or modifications shall not be construed as a waiver of these terms and conditions or an acceptance of any such provisions.

4. WARRANTY: NK Technologies warrants its products to be free of defects in material and workmanship for a period of five (5) years after receipt by Buyer unless otherwise stated in the product literature. This warranty does not apply to any products or parts not purchased as new from NK Technologies or its authorized distributors or any products or parts not manufactured by NK Technologies; provided however, NK Technologies does agree to assign and transfer to Buyer, insofar as it is permitted by contract or law, the manufacturer's warranty pertaining to any such products. If any NK Technologies' manufactured product fails to conform to the warranty applicable to such product, NK Technologies' sole and exclusive liability shall be, at its option, to repair, replace or credit Buyer's account an amount equal to the price paid for such products which are returned during the acceptable warranty period by Buyer with such product's manufacturing date code intact. This warranty shall not apply to products damaged by abuse, neglect, accident, modification, alteration or mis-use. Normal wear is not warranted. Notice of defects must be received within the warranty period or the warranty is void. NK TECHNOLOGIES NEITHER ASSUMES NOR AUTHORIZES ANY PERSON TO ASSUME ANY OTHER LIABILITIES IN CONNECTION WITH THE SALE OR USE OF ANY PRODUCTS. THE FOREGOING WARRANTIES ARE IN LIEU OF ALL OTHER WARRANTIES, EXPRESS OR IMPLIED. THIS EXCLUSION MEANS THERE IS NO IMPLIED WARRANTY OF MERCHANTABILITY AND NO IMPLIED WARRANTY OF FITNESS FOR ANY PARTICULAR PURPOSE, TECHNICAL ASSISTANCE OR INFORMATION PROVIDED BY NK TECHNOLOGIES OR THE COMPANY'S PERSONNEL. ANY SUGGESTIONS BY THE COMPANY REGARDING USE, SELECTION, APPLICATION OR SUITABILITY OF THE PRODUCTS SHALL NOT BE CONSTRUED AS AN EXPRESS WARRANTY UNLESS SPECIFICALLY DESIGNATED AS SUCH IN WRITING, SIGNED BY AN OFFICER OF THE COMPANY. THIS EXCLUSION ALSO MEANS THAT NK TECHNOLOGIES GRANTS NO IMPLIED WARRANTIES ARISING WITH RESPECT TO USAGE OF TRADE, COURSE OF DEALING OR COURSE OF PERFORMANCE, AND NONE SHALL ARISE OUT OF ANY SALE UNDER THIS AGREEMENT OR OUT OF EITHER PARTY'S CONDUCT.

5. PAYMENTS: Unless otherwise agreed by the Company, all orders are due for payment immediately upon confirmation of the order by the

Company; provided, however, the Company, at its sole discretion, may grant payment terms of net thirty (30) days from date of shipment. Under certain circumstances (sales outside of the United States, special order products and/or lack of acceptable Buyer credit history), the Company reserves the right to require the prepayment of all or a portion of an invoice in advance of shipment. If an invoice is paid by credit card, a processing fee may be charged and paid by Buyer at the Company's discretion. In addition, a transaction fee may be applied if an invoice is paid with a foreign credit card. These credit card fees will be applied and added to the invoice. International Buyer(s) must pay incoming and outgoing wire transfer fees unless otherwise agreed. A finance charge of one percent (1.0%) per month will be calculated on a daily basis and shall be payable on any outstanding balance from the date payment was due until the date payment is received by the Company; without prejudice to the Company's other rights with respect to non-payment or a late payment. Buyer shall not withhold payment or make any deduction or set off from the price. If Buyer is placed on credit hold by the Company due to past due outstanding invoice(s) or if at any time Buyer's credit becomes unsatisfactory, Buyer agrees that NK Technologies has the right to withhold delivery of any pending product shipments and suspend Buyer's existing net payment or credit terms and change such terms to prepayment. All costs and expenses incurred by the Company as a result (direct or indirect) of such suspension and any commencement shall be payable by Buyer upon demand. The Company reserves the right to submit any late unpaid invoices to a third party for collection and Buyer shall pay all reasonable costs including, but not limited to, debt collection expenses, legal fees, court costs and other charges to settle such collection in addition to the invoice amount. All quoted prices and payments shall be in U.S. Dollars (USD).

6. TAXES: Any sales taxes, use taxes, excise taxes, tariffs, duties, customs, inspection and testing fees, value-added taxes, customs storage fees, Shipper's Export Declaration (SED) fees, special handling fees, any applicable international trade fees of any nature imposed or collected by any government authority must be paid by Buyer in addition to the amount invoiced. In the event the Company is required to pay any such tax, fee or charge, Buyer agrees to reimburse NK Technologies upon demand. In the event Buyer claims an exemption from the imposition of such tax, fee or charge, Buyer will be required to provide a resale certificate or similar document acceptable to the authority imposing such tax, fee or charge. Buyer shall indicate at time of order placement any sale is tax exempt.

7. SHIPPING METHOD AND CHARGES: NK Technologies shall package products for normal shipping conditions. The Company shall select the freight carrier, method and routing. Shipping charges are prepaid and added to a Buyer's invoice; however, the Company reserves the right to ship freight-collect at its discretion. Shipping charges may include a charge for any special packaging, at the Company's discretion. Certain handling fees may be added to the product price if additional cost is incurred/required for any special labeling and/or packaging requirements or due to regulations imposed by any Government. No third-party freight billing will be permitted without the Company's prior written consent.

8. RETURNS: Unless otherwise agreed in writing by the Company, all sales of products by NK Technologies become final, non-cancelable, non-returnable and non-refundable at the time an order is confirmed by the Company. Written authorization must be obtained from the Company before returning any product for which Buyer expects replacement, exchange, repairs, or credit within the warranty period. Return goods can only be returned when approved by the Company under strict compliance with NK Technologies' return shipment instructions. Product(s) that have been opened and used will not be accepted for return. Prior to returning any products, Buyer must obtain a pre-approved Return Material Authorization (RMA) number issued by NK Technologies. At its discretion, NK Technologies may allow the return of product purchased within the prior one hundred and eighty (180) day period in exchange for: (1) a restocking fee of twenty five percent (25%) of the invoice amount in addition to other costs incurred by the Company and/or (2) an offsetting order for a value amount equal to or exceeding that of the product returned. Return of products categorized as "NCR", non-cancelable or non-



returnable or those made with non-standard material or other material provided specially to meet Buyer's specifications shall not be returnable for any reason. If qualified for return, Buyer is responsible arranging and paying for shipping and handling and any other charges, including any insurance or custom charges, if applicable. The Company at its discretion may pay standard ground freight charges for items being returned to Buyer which are repaired or replaced within the warranty period. Approved credit memos will be applied to Buyer's account and Buyers may use such credit against future purchases from NK Technologies. Buyer agrees that NK Technologies will not issue any refund payments or checks for such credit amount or credit memo.

9. EVALUATION: NK Technologies, at its sole discretion, may offer products for evaluation purposes. The evaluation period starts on the date evaluation products are received by Buyer and remains in effect for 30 business days. Buyers are responsible for shipping, handling, insurance, customs, bank fees, taxes, other applicable charges resulting from the shipment of evaluation units to and from NK Technologies. In addition, Buyers shall obtain all necessary governmental permits, licenses and clearances and comply with all applicable laws, and regulations. Buyers shall bear all risk of loss of products until the evaluation units are returned to NK Technologies. NK Technologies will process 100% of the invoice amount as a prepaid security deposit for the evaluation units before the order is confirmed and added to production queue. Prior to the end of the evaluation period, Buyers must notify NK Technologies of their decision on the evaluation units via email. If Buyer elects to keep the units, the security deposit will be applied to the purchase price. All test results shall be provided to NK Technologies to assist in the further development of the product. If Buyer decides to return the evaluation units, a Return Material Authorization (RMA) approval and number must be obtained from Company's sales department prior to the return. Returned evaluation units must be in the same condition as when shipped to Buyer. NK Technologies will conduct a quality test once the units are returned and generate a report on the condition of the products. Neither Buyer nor its personnel or agents shall modify, enhance, change settings, burn, create derivative works from, reverse engineer, de-compile, disassemble and/or reduce the products. Buyers shall be responsible for the full cost of any loss or damage to the evaluation products. Buyer warrants and represents that it has insurance to cover such loss and damage. At NK Technologies' sole direction, a credit may be issued based on the condition of the units. NK's sales department will notify Buyer of a refund, if any, via email. This process may take 6-10 days after receipt of the RMA evaluation units.

10. DELIVERY SCHEDULES/FORCE MAJEURE: Orders are generally shipped on the date specified and acknowledged on the Company's order confirmation sent to Buyer upon acceptance of an order(s). NK Technologies does not guarantee the date of shipment nor the date of Buyer's receipt of the items. In the event Buyer requires delivery of product(s) prior to the Company's scheduled shipment date, NK reserves the right to charge an expedite fee. NK Technologies will not be liable for any loss, damage or penalty due to delays in delivery or for the failure to perform its obligations due to causes beyond its reasonable control including, but not limited to, material shortages, transportation delays, unforeseen circumstances, embargo or other governmental act, regulation or request affecting the conduct of Company's business, acts of God, acts or omissions of other parties including Buyer, acts or omissions of civil or military authorities, Government priorities, fires, explosions, accidents, thefts, vandalism, lightning, windstorm, floods, severe weather conditions, computer interruptions, terrorism, epidemics, quarantine restrictions, strikes, riots or war, labor disputes, other labor difficulties and failure in manufacturing, inability to obtain necessary labor, fuel, materials, supplies or parts at current prices. NK Technologies' time for delivery or performance will be extended by the period of any such delay or NK Technologies may, at its option, cancel any order or remaining part thereof, without liability, by giving notice to Buyer.

11. TITLE: Title to the products will pass to Buyer upon delivery to the carrier at the EXWORKS or FOB point; provided however, NK Technologies will retain a purchase money security interest in each product until all of its claims arising out of the furnishing of such products have been satisfied

in full. All risk of loss or damage to the products will pass to Buyer upon delivery to the carrier at the FOB or EXWORKS point; the carrier acting as Buyer's agent.

12. LIABILITY: BUYER AGREES THAT NK TECHNOLOGIES SHALL NOT BE RESPONSIBLE OR LIABLE FOR ANY SPECIAL, INDIRECT, INCIDENTAL, CONSEQUENTIAL OR SPECIAL DAMAGES OF ANY KIND, HARM AND/OR ACCIDENT RESULTING FROM THE SALE AND ANY USE OR FAILURE OF THE PRODUCTS, EVEN IF NK TECHNOLOGIES HAS BEEN ADVISED OF THE POSSIBILITY OF SUCH DAMAGE INCLUDING WITHOUT LIMITATION, LIABILITY FOR LOSS OF USE, LOSS OF WORK IN PROGRESS, DOWNTIME, LOSS OF DATA, LOSS OF GOODWILL, LOSS OF REVENUE OR PROFITS, FAILURE TO REALIZE SAVINGS, LOSS OF PRODUCTS OF BUYER OR OTHER USE OR ANY LIABILITY OF BUYER TO A THIRD PARTY ON ACCOUNT OF SUCH LOSS, OR FOR ANY LABOR OR ANY OTHER EXPENSE, DAMAGE OR LOSS OCCASIONED BY SUCH PRODUCT INCLUDING PERSONAL INJURY OR PROPERTY DAMAGE. NK Technologies and its officers, shareholders, directors, employees, agents and vendors will not be held liable for any kind of loss, direct or indirect damages including, but not limited to, business interruptions, injury, loss of any kind, damages of any kind resulting in any way from any errors or omission or any services or product, warranties of quality and merchantability, accuracy, and fitness for any particular purpose.

13. INDEMNIFICATION: It is the sole and exclusive responsibility of Buyer to determine the suitability and ability to use any and all NK Technologies' products for Buyer's use. Buyer agrees to indemnify, defend, and hold NK Technologies and NK Technologies' employees, officers, directors, owners and agents harmless from and against all claims, losses, expenses, damages and costs (including, but not limited to, direct, incidental, special, consequential, punitive, exemplary and indirect damages), and agrees to reimburse NK Technologies its reasonable attorneys' fees in defending any claim resulting from or arising out of Buyer's use, misuse or inability to use the products, or any related activities, or any violation by Buyer of these conditions of order. It is Buyer's sole responsibility to review and observe all the terms and condition stated hereby carefully prior to operating NK Technologies' products to make an informed decision.

14. INTELLECTUAL PROPERTY RIGHTS: THE COMPANY EXPRESSLY DISCLAIMS ALL REPRESENTATIONS AND WARRANTIES CONCERNING THE SCOPE OR VALIDITY OF ANY INTELLECTUAL PROPERTY RIGHTS ASSOCIATED WITH ITS PRODUCTS AND EXPRESSLY DISCLAIMS ANY WARRANTY THAT THE DESIGN, DEVELOPMENT, ADVERTISING, MARKETING OR SALE OF THE PRODUCTS OR THE USE OF THE PRODUCTS BY BUYER WILL NOT INFRINGE UPON ANY PATENT, COPYRIGHT, TRADEMARK OR OTHER PROPRIETARY RIGHTS OF ANY THIRD PARTY. ANY WARRANTY THAT MAY BE PROVIDED IN ANY APPLICABLE PROVISION OF THE UNIFORM COMMERCIAL CODE OR ANY OTHER COMPARABLE LAW OR STATUTE IS EXPRESSLY DISCLAIMED. BUYER HEREBY ASSUMES ALL RISK OF INFRINGEMENT.

15. CALIFORNIA'S PROPOSITION 65 NOTICE: NK Technologies has no actual knowledge of any cancer or birth defect causing chemical being used in its product(s) and, unless otherwise expressly agreed in a written instrument (signed by both parties), does NOT agree to indemnify, defend and/or hold a Buyer of its products harmless from the Company's potential violation of law and/or any claim arising from the Company's failure to properly label NK Technologies' products as may be required by California's Proposition 65 (as amended).

16. GOVERNING LAW: This contract shall be governed by and construed according to the laws of the State of California, U.S.A. The parties agree that any and all legal proceedings pursuant to this contract shall take place under the jurisdiction of the courts of the State of California in the judicial district of Santa Clara County.

Rev. October 19, 2022

Terms and Conditions are subject to change without prior notice. The latest version of Terms and Conditions of Sales take precedence, and can be found on our website @ www.nktechnologies.com

INDEX BY NAME

| | | | | | |
|----------------------------|-----|---------------------------|-----|---------------------------|-----|
| ADC SERIES | 134 | ASM SERIES | 16 | CURRENT TRANSFORMERS..... | 141 |
| AG SERIES | 93 | ASP-FD SERIES | 26 | DG SERIES | 109 |
| AGL SERIES | 98 | ASX SERIES | 24 | DIN RAIL KITS..... | 147 |
| AG-LC SERIES | 101 | ASXP SERIES | 28 | DLT SERIES | 88 |
| AGLD SERIES | 103 | ASXP-LS SERIES | 32 | DS1 SERIES | 34 |
| AGT SERIES | 105 | ASXP-MS SERIES | 30 | DS1-FD SERIES | 38 |
| AGT-FD SERIES | 107 | AT SERIES | 42 | DS3 SERIES | 36 |
| AGV SERIES | 96 | AT/ATR-FD SERIES | 48 | DT SERIES, 3-WIRE | 78 |
| AMPFLASHER™ | | AT/ATR-FL SERIES | 50 | DT SERIES, 4-WIRE | |
| ACI SERIES | 146 | AT/ATR-LS SERIES | 54 | SPLIT-CORE | 73 |
| APN SERIES | 123 | AT/ATR-MS SERIES | 52 | SOLID-CORE | 76 |
| APN-R SERIES | 125 | AT/ATR-TH SERIES..... | 46 | DT SERIES, 5 & 12 VDC | |
| APS SERIES | 127 | ATCR SERIES | 56 | POWERED | 80 |
| APT SERIES | 129 | ATH SERIES | 64 | DT-BB SERIES, | |
| APT-TH SERIES | 131 | ATP SERIES | 58 | HV BUS BAR | 84 |
| AS0 SERIES | 22 | ATP/ATPR-FL SERIES | 62 | DT-DL SERIES, | |
| AS1 SERIES | 6 | ATPR VOLTAGE | | LARGE APERTURE | 86 |
| AS1 SERIES | | OUTPUT SERIES | 60 | DT-FD SERIES, | |
| COMPACT CASE | 13 | ATQ SERIES | 66 | HIGH VOLTAGE | 82 |
| AS1 NOR-FT-GO SERIES | 8 | ATR SERIES | 44 | PROTECT™ SERIES | 145 |
| AS3 SERIES | 10 | ATS SERIES DIGITAL | 68 | VTD SERIES | 114 |
| ASC SERIES | 18 | ATS SERIES ROTARY | 70 | VTD-BD SERIES..... | 116 |
| ASD SERIES | 20 | CT-MS & CT-LS SERIES..... | 139 | VTR SERIES | 112 |
| ASL SERIES | 14 | CTC SERIES | 136 | VTU-DIN SERIES | 120 |
| | | CTRC SERIES | 143 | VTU SERIES | 118 |



INDEX BY PRODUCT

Current Sensing Switches4

| | |
|----------------------------------|----|
| AS1 SERIES | 6 |
| AS1 NOR-FT-GO SERIES | 8 |
| AS3 SERIES | 10 |
| AS1 SERIES COMPACT CASE | 13 |
| ASL SERIES | 14 |
| ASM SERIES | 16 |
| ASC SERIES | 18 |
| ASD SERIES | 20 |
| AS0 SERIES | 22 |
| ASX SERIES | 24 |
| ASP-FD SERIES | 26 |
| ASXP SERIES | 28 |
| ASXP-MS SERIES | 30 |
| ASXP-LS SERIES | 32 |
| DS1 SERIES | 34 |
| DS3 SERIES | 36 |
| DS1-FD SERIES | 38 |

AC Current Transducers40

| | |
|------------------------|----|
| AT SERIES | 42 |
| ATR SERIES | 44 |
| AT/ATR-TH SERIES..... | 46 |
| AT/ATR-FD SERIES | 48 |
| AT/ATR-FLSERIES | 50 |
| AT/ATR-MS SERIES | 52 |
| AT/ATR-LS SERIES | 54 |
| ATCR SERIES | 56 |
| ATP SERIES | 58 |

| | |
|---|----|
| ATPR VOLTAGE OUTPUT SERIES | 60 |
| ATP/ATPR-FL SERIES | 62 |
| ATH SERIES | 64 |
| ATQ SERIES | 66 |
| ATS SERIES WITH DIGITAL DISPLAY..... | 68 |
| ATS SERIES WITH ROTARY DISPLAY..... | 70 |

DC Current Transducers.....72

| | |
|--|----|
| DT SERIES, 4-WIRE SPLIT-CORE | 73 |
| SOLID-CORE | 76 |
| DT SERIES, 3-WIRE | 78 |
| DT SERIES, 5 & 12 VDC POWERED | 80 |
| DT-FD SERIES, HIGH VOLTAGE | 82 |
| DT-BB SERIES, HV BUS BAR | 84 |
| DT-DL SERIES, LARGE APERTURE | 86 |
| DLT SERIES | 88 |

Ground Fault Protection90

| | |
|---------------------|-----|
| AG SERIES | 93 |
| AGV SERIES | 96 |
| AGL SERIES | 98 |
| AG-LC SERIES | 101 |
| AGLD SERIES | 103 |
| AGT SERIES | 105 |
| AGT-FD SERIES | 107 |

| | |
|-----------------|-----|
| DG SERIES | 109 |
|-----------------|-----|

Voltage Transducers..... 111

| | |
|----------------------|-----|
| VTR SERIES | 112 |
| VTD SERIES | 114 |
| VTD-BD SERIES | 116 |
| VTU SERIES | 118 |
| VTU-DIN SERIES | 120 |

Power Sensing Products.. 122

| | |
|---------------------|-----|
| APN SERIES | 123 |
| APN-R SERIES | 125 |
| APS SERIES | 127 |
| APT SERIES | 129 |
| APT-TH SERIES | 131 |

Signal Converters 133

| | |
|------------------|-----|
| ADC SERIES | 134 |
| CTC SERIES | 136 |

Current Transformers 138

| | |
|------------------------------|-----|
| CT-MS & CT-LS SERIES..... | 139 |
| CURRENT TRANSFORMERS..... | 141 |
| CTRC SERIES | 143 |
| PROTECT™ SERIES | 145 |

AMPFlasher..... 146

| | |
|---------------------------------|-----|
| AMPFLASHER™ ACI SERIES | 146 |
|---------------------------------|-----|

Accessories..... 147

| | |
|--------------------|-----|
| DIN RAIL KITS..... | 147 |
|--------------------|-----|

For the most current
and up-to-date information...

www.nktechnologies.com

- Up-to-date Product Information
- Data Sheets & Instruction Sheets
- CAD Drawings
- Product Certifications
- Request for Quote
- Support
- Application Examples
- Engineering Resource Articles
- Sign up for Product Updates
- Distributor Information
- ... and so much more!



Visit our website for all the technical,
application and support information that you
could ever want or need!



3511 Charter Park Drive • San Jose, CA 95136
800.959.4014 • sales@nktechnologies.com
www.nktechnologies.com

For expert technical help, contact your local Authorized Representative or
Authorized Distributor.

