

High Performance Current Sensing for Automation Applications

PRODUCT CATALOG

2018



- Current Sensing Switches
- AC Current Transducers
- DC Current Transducers
- Ground Fault Protection
- Voltage Transducers
- Power Sensing Products
- Signal Converters
- Current Transformers
- AMPFlasher™ Current Indicator
- Accessories

www.nktechnologies.com

800.959.4014



Current Sensors for Automation

A Company Built Upon A History Of Innovation

Founded in 1982, when Maynard Kuljian saw the need for an economical way to measure current draw, Neilsen-Kuljian, Inc., became the first to develop the low-cost solid-state current sensing technology that underlies the industry today.

True to this heritage, NK Technologies has maintained a focus on developing and manufacturing innovative, cost-effective current sensing products designed to add value and to meet or exceed our customers' performance expectations. With a portfolio of over 1300 models, NK Technologies remains a leading supplier of current measurement solutions to the industrial and factory automation markets. As the needs of these markets change, NK Technologies is well-positioned to respond with sophisticated new product designs and improved product functionality necessary to meet those applications.

As a leader in the industry, NK Technologies takes its commitment to customers seriously and considers customer satisfaction a top priority. Timely response to customer inquiries; knowledgeable technical support; a willingness to develop custom solutions to meet specific customer needs; and an organizational commitment to delivering reliable, quality product on time are the hallmarks of excellence which our customers have come to rely on and expect from NK Technologies, a company built upon a history of innovation.



www.nktechnologies.com

Go online for more information

- Up-to-date Product Information
- Application Examples
- Engineering Resource Articles
- Sign Up for Product Updates
- Distributor Information

For over three decades, NK Technologies has remained the **premier manufacturer** of Current Sensors and Transducers serving the factory and industrial automation markets.

With one of the broadest product portfolios in the industry, NK Technologies provides reliable, innovative current sensing products designed to add value and exceed our customers' expectations. "From motor monitoring to heater status, semiconductor tools to water/wastewater plants, NK Technologies has a family of current sensors to meet your application needs." — Phil Gregory, President

CONTENTS

Current Sensing Switches4	Ground Fault Protection 80	AMPFlasher™ 127
Selection Guide.....page 5	Selection Guide.....page 80	AMPFlasher™ ACI
AS1, AS1 Compact Case, AS1	AG, AGL, AGLD, AGT, DG	Accessories 128
NOR-FT-GO, AS3, ASL, ASM, ASC, ASD, ASO,	Voltage Transducers 93	DIN Rail Kits
ASX, ASP-FD, ASXP, ASXP-MS, ASXP-LS, ATS,	Selection Guide.....page 93	Index by Name 129
DS1, DS3	VTR, VTD, VTD-BD, VTU, VTU-DIN	Index by Product 130
AC Current Transducers 38	Power Sensing Products 104	RoHS 2/ISO/Terms & Conditions
Selection Guide.....page 39	Selection Guide.....page 104	See the Inside Back Cover of this catalog for:
AT, ATR, AT/ATR-FD, AT/ATR-FL,	APN, APN-R, APS, APT, APT-TH	• RoHS 2 Certificate of Compliance
AT/ATR-MS, AT/ATR-LS, ATCR, ATP, ATPR,	Signal Converters 115	• ISO 9001 DNV Certification
ATP/ATPR-FL, ATH, ATQ, ATS	Selection Guide.....page 115	• Terms & Conditions
DC Current Transducers 68	ADC, CTC	
Selection Guide.....page 68	Current Transformers 120	
DT 4-Wire, DT 3-Wire, DT Temperature	CT-MS & CT-LS, Current Transformers,	
Compensated, DT Large Aperture, DLT	CTRC, ProteCT™,	

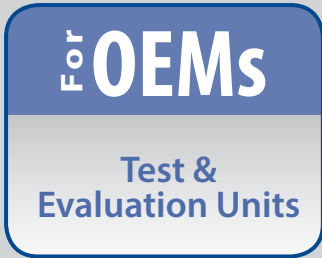

We will help you ... for FREE!

The New NK Technologies Test & Evaluation Program can expedite your evaluation process by getting the right product in your engineers hands for evaluation fast and free!

- ✓ **Are you an OEM using switches and transducers on the equipment you sell to your customers?**
- ✓ **Are you looking for a test & evaluation unit?**
- ✓ **Would you like to avoid the time & hassle associated with buying a unit?**

Get your design moving forward by following these simple steps:

- #1 - Complete following form at www.nktechnologies.com/testunit/
- #2 - Meet either in person or by telephone with our Application Engineering team to discuss your product selection so we can confirm the product you have selected is best for your application.

#3 - NK Technologies will ship you your test & evaluation unit at no cost.

#4 - You agree to meet either in person or by phone sometime in the next 60 days to review the product operation, analyze test results and coordinate a plan to move forward with the design.

It's that easy ... so start today!



Current Sensing Switches

Ideal for off/on status, overload or underload indication, current sensing switches from NK Technologies combine a CT, signal conditioner and output contacts into a single package for use with industrial and factory automation equipment.

Features:

- Multiple output ranges
- Adjustable or fixed setpoints
- Models with integral time delay available
- Choice of N.O or N.C., AC or DC contacts
- Self-powered and split-core options

• AS1 SERIES	Current Sensing Switches	page 6
• AS1 SERIES COMPACT CASE	AC Current Sensing Switches	page 13
• AS1 NOR-FT-GO SERIES	Current Sensing Switches	page 8
• AS3 SERIES	Current Sensing Switches	page 10
• ASL SERIES	Linear Adjustment Setpoint Switches	page 14
• ASM SERIES	Self-calibrating Current Sensing Smart Switches.....	page 16
• ASC SERIES	Factory-calibrated Current Operated Switches	page 18
• ASD SERIES	Current Sensing Switches	page 20
• AS0 SERIES	Current Sensing Switches	page 22
• ASX SERIES	Current Sensing Switches	page 24
• ASP-FD SERIES	Current Sensing Switches	page 26
• ASXP SERIES	Current Sensing Switches	page 28
• ASXP-MS SERIES	Current Sensing Switches	page 30
• ASXP-LS SERIES	Current Sensing Switches	page 32
• ATS SERIES WITH DIGITAL SETPOINT DISPLAY	Current Sensing Transducers/Switches	page 64
• ATS SERIES WITH ROTARY SWITCH SETPOINT	Current Sensing Transducers/Switches	page 66
• DS1 SERIES	DC Current Sensing Switches	page 34
• DS3 SERIES	Current Sensing Switches	page 36

CURRENT SENSING SWITCHES Selection Chart

MONITOR DC LOADS

DS1 SERIES – p. 34
Compact, Solid-State

DS3 SERIES – p. 36
Hall-effect Sensor

MONITOR AC LOADS

Load 1–150 A
(Single Range)

AS1 SERIES – p. 6
Adjustable Setpoint, Go-No-Go or Manual Bypass

ASL SERIES – p. 14
Single-turn Adjustment

ASM SERIES – p. 16
Self-calibrating Smart-Switch

ASC SERIES – p. 18
Factory-calibrated Setpoint

ASD SERIES – p. 20
Rotary Setpoint Selection, Digital Display

Load 0.5 A or higher
(Non-adjustable)

AS1 SERIES COMPACT CASE – p. 13
Go-No-Go, Small Housing

Load 1.5–200 A
(Selectable Ranges)

AS3 SERIES – p. 10
Immediate Contact Action

ASX SERIES – p. 24
Optional Delay on Current Rise

ATS SERIES – p. 64
Current Transducer/Switch, Digital Display Setpoint

Load 0.75–50 A

ASXP SERIES – p. 28
SPST Relay Output

Load > 6 A

AS1 NOR-FT-GO SERIES – p. 8
SPST Relay Output

Load < 350 mA

AS0 SERIES – p. 22
Ultra-low Current Sensor

Load < 400 A

ASP-FD SERIES – p. 26
Dual Relay Outputs

Load 0–800 A

ASXP-MS SERIES – p. 30
SPDT Relay Output

Load 0–1200 A

ATS SERIES – p. 66
Current Transducer/Switch, Rotary Setpoint Selection

Load 0–1600 A

ASXP-LS SERIES – p. 32
SPDT Relay Output



AS1 SERIES

Current Sensing Switches

AS1 Series Current Sensing Switches combine a current transformer, signal conditioner and limit alarm into a single package for use in status monitoring or proof of operation applications. Offering an extended setpoint range of 1–150 A and universal, solid-state outputs, the self-powered AS1 can be tailored to provide accurate and dependable digital indication of overcurrent conditions across a broad range of applications. Available in solid-core case styles or in a split-core case to maximize ease of installation.



Current Sensing Switch Applications

Electronic Proof of Flow

- Current sensing switches eliminate the need for multiple pipe or duct penetrations and are more reliable than electromechanical pressure or flow switches.

Conveyors

- Detects jams and overloads.
- Interlocks multiple conveyor sections.

Lighting Circuits

- Proof positive that the lamp is energized.

Electrical Heaters

- Faster response than temperature sensors.

Current Sensing Switch Features

Universal Output

- N.O. or N.C. solid-state switch for control circuits up to 240 VAC/DC.
- Compatible with most automation systems.

Self-powered

- Cuts installation and operating costs.

Easily Adjustable Setpoint

- Speeds startup.

Solid or Split-core Case

- Versions tailored for each installation.

LED Indication

- Provides quick visual indication of contact status.

Built-in Mounting Feet

- Simple, two-screw panel mounting or attach with DIN rail brackets (ncluded).*

UL/cUL and CE Approved

- Accepted worldwide.

*For information on the DIN rail accessories kit, see page 128.

Pump Jam & Suction Loss Protection

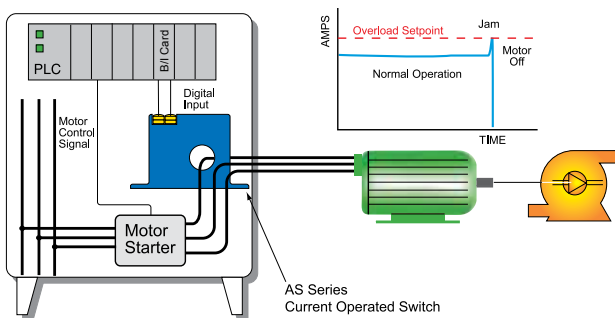

For additional Application Examples, go to www.nktechnologies.com/applications

Current Sensing Switch Connections

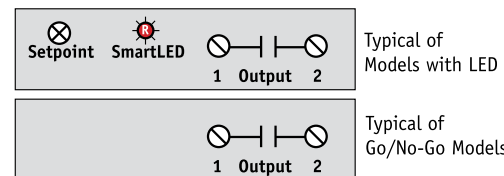

OEMs Test & Evaluation Units for OEMs
Free program expedites evaluation process. See page 3 for details.

Current Sensing Switch Dimensions

FF Case

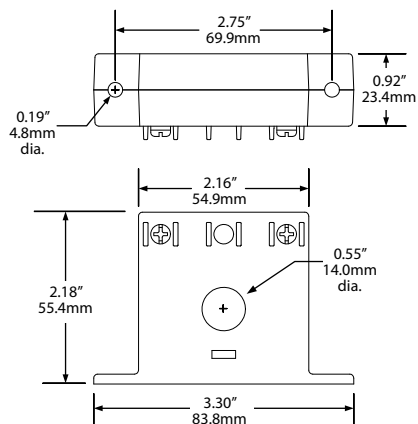

FT Case

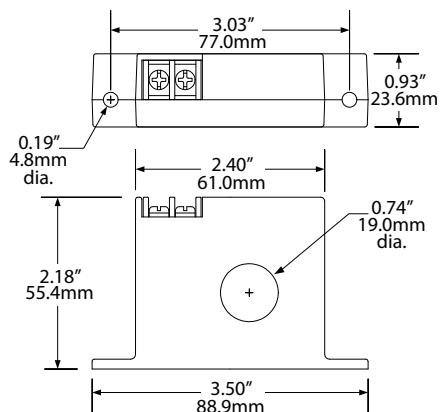

SP Case

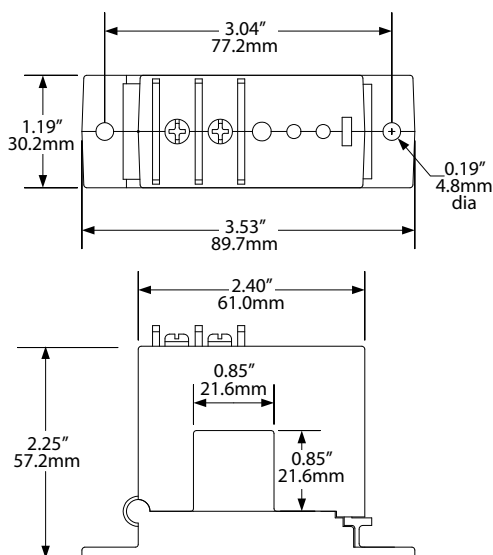

Current Sensing Switch Specifications



Power Supply	None, self-powered												
Setpoint Range	<ul style="list-style-type: none"> • Solid-core: 1–150 A (adjustable-specific models) • Split-core: 1.75–150 A (adjustable-specific models) 												
Output Description	Isolated solid-state relay												
Output Rating	<ul style="list-style-type: none"> • N.O. Version 0.15 A @ 240 VAC or VDC • N.C. Version: 0.2 A @ 135 VAC or VDC • Not polarity sensitive 												
Off-state Leakage	<10 μ A												
Response Time	120 ms max.												
Time Delay	None												
Hysteresis	5%												
Overload	<table border="1"> <thead> <tr> <th>MODEL</th> <th>6 SEC.</th> <th>1 SEC.</th> </tr> </thead> <tbody> <tr> <td>• -GO (NOU)</td> <td>• 500 A</td> <td>• 1000 A</td> </tr> <tr> <td>• -GO (NCU)</td> <td>• 400 A</td> <td>• 1000 A</td> </tr> <tr> <td>• All other</td> <td>• 400 A</td> <td>• 1000 A</td> </tr> </tbody> </table>	MODEL	6 SEC.	1 SEC.	• -GO (NOU)	• 500 A	• 1000 A	• -GO (NCU)	• 400 A	• 1000 A	• All other	• 400 A	• 1000 A
MODEL	6 SEC.	1 SEC.											
• -GO (NOU)	• 500 A	• 1000 A											
• -GO (NCU)	• 400 A	• 1000 A											
• All other	• 400 A	• 1000 A											
Isolation Voltage	UL listed to 1270 VAC, tested to 5 KV												
Frequency Range	6–100 Hz												
Case	UL94 V-0 Flammability Rated												
Environmental	-4 to 122°F (-20 to 50°C) 0–95% RH, non-condensing												
Listings	UL /cUL, CE												

Current Sensing Switches

Current Sensing Switch Ordering Information

Sample Model Number: AS1-NOU-SP

Adjustable AC current sensing switch, normally open, split-core case. (DIN rail adapters are included)



(1) Output Rating

NOU	Normally Open
NCU	Normally Closed

(2) Case Style

FF	Solid-core, Front Term.
FT	Solid-core, Top Term.
SP	Split-core

(3) Options

GO	Non-adjustable; output changes with min. current present (solid-core 0.75 A, split-core 1.25 A)
NL	No LED
Y39	Output Bypass Switch (not UL listed) – available for FT case only
	Standard, with LED (blank)



AS1 NOR-FT-GO SERIES

Current Sensing Switches

AS1 NOR-FT-Go Series Current Sensing Switches provide an electromechanical relay contact. The output of this specialized switch allows the sensor to control much more current than other AS1 models. This contact can control loads up to 5 A, AC or DC. Solid-state contacts generally have a much lower capacity, making this sensor much more versatile than most self-powered models. Available in a solid-core case only.



Current Sensing Switch Applications

Electronic Proof of Flow

- Current sensing switches eliminate the need for multiple conduits or duct penetrations and are more reliable than electromechanical pressure or flow switches.

Compressor Monitoring

- Detect when the compressor is running.
- Allows for time of use logging; helps maintenance scheduling.

Heaters

- Sense system operation.

Fan Interlocks

- Sense system operation.
- Use to turn on a duct booster fan when clothes dryer is energized.

Current Sensing Switch Features

Electromechanical Output

- N.O. mechanical output relay for detection of current; closes on current increase.

Fixed Setpoint

- Cuts installation and operating costs.

Self-powered

- Reduces installation time and costs.

Integral Mounting Feet

- Built-in feet for direct panel mounting or attachment of DIN rail compatible brackets.*

UL/cUL and CE Approved

- Accepted worldwide.

*For information on the DIN rail accessories kit, see page 128.

Current Sensing Switch Monitoring a Fan Load

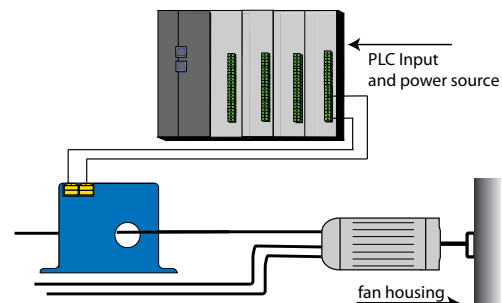

Motor current causes the relay contact to close, and if the coupling breaks the current falls and the sensor output opens again

- For additional Application Examples, go to www.nktechnologies.com/applications

OEMs

Test & Evaluation Units for OEMs

Free program expedites evaluation process. See page 3 for details.

Current Sensing Switch Dimensions

FT Case

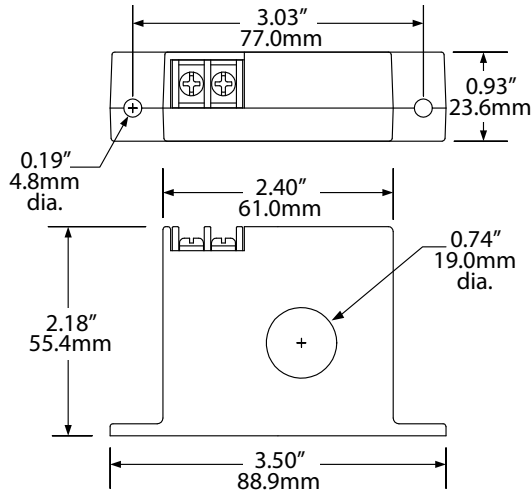

Current Sensing Switch Specifications



Power Supply	None, self-powered
Setpoint Range	Go/No-go 5.8 A (factory set)
Output Description	Electromechanical SPST relay
Output Rating	• 5 A @ 250 VAC • 5 A @ 30 VDC
Response Time	120 ms
Time Delay	None
Hysteresis	8%
Overload	6 sec. @ 400 A, 1 sec. @1000 A
Isolation Voltage	UL listed to 1270 VAC, tested to 5 KV
Frequency Range	6–100 Hz
Case	UL94 V-0 Flammability Rated
Environmental	-4 to 122°F (-20 to 50°C) 0–95% RH, non-condensing
Listings	UL/cUL, CE

Current Sensing Switches

Current Sensing Switch Connections

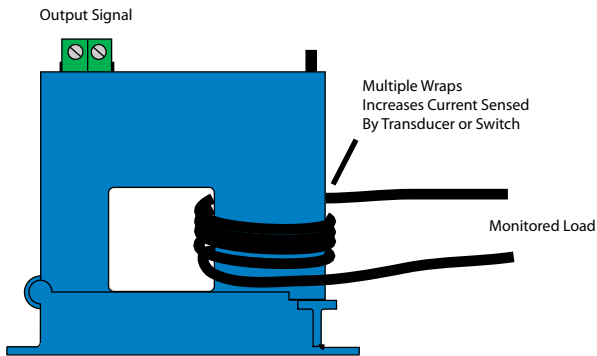
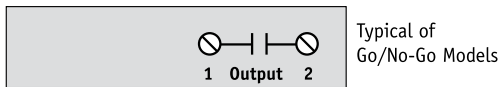

Current Sensing Switch Ordering Information

Sample Model Number: AS1-NOR-FT-GO

AC current operated switch, solid-core, non-adjustable trip point (5.6 A), self-powered, normally open relay contact output rated to 5 A. (DIN rail adapters are included)



(1) Output Rating

NOR	Normally Open (mechanical)
-----	----------------------------

(2) Case Style

FT	Solid-core, Top Terminals
----	---------------------------

(3) Options

GO	Go/no-go version (fixed-setpoint)
----	-----------------------------------



AS3 SERIES

Current Sensing Switches

AS3 Series Current Sensing Switches provide the same dependable indication of status offered by the AS1, but with the added benefit of increased setpoint accuracy. A choice of three, jumper-selectable input ranges allows the AS3 to be tailored to an application, providing more precise control through improved setpoint resolution. Self-powering, isolated solid-state outputs, 1–6 A, 6–40 A and 40–200 A input ranges, and a choice of split- or solid-core case are standard.

Current Sensing Switch Applications

Electronic Proof of Flow

- No need for pipe or duct penetrations.
- More reliable than electromechanical pressure or flow switches.

Conveyors

- Detects jams and overloads.
- Interlocks multiple conveyor sections.

Lighting Circuits

- Easier to install and more accurate than photocells.

Electrical Heaters

- Faster response than temperature sensors.

Pump Jam & Suction Loss Protection

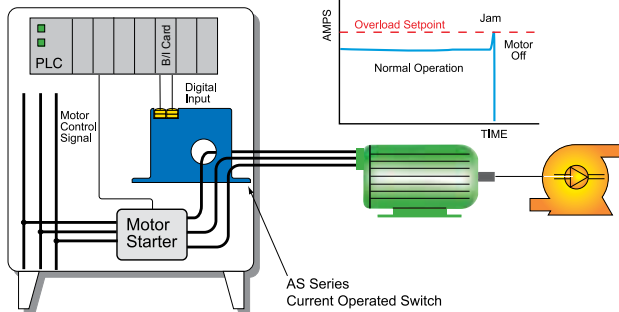

- For additional Application Examples, go to www.nktechnologies.com/applications

OEMs

Test & Evaluation Units for OEMs

Free program expedites evaluation process. See page 3 for details.



Current Sensing Switch Features

Choice of N.O. or N.C. Solid-State Outputs

- 1 A @ 240 VAC, 0.15 A @ 30 VDC.
- 15 A @ 120 VAC (-15 model).
- 3 A @ 120 VAC output optional.

Self-powered

- Cuts installation and operating costs.

Easily Adjustable Setpoint

- Speeds startup.

Solid- or Split-core Case

- Choose the appropriate version for each installation.

LED Indication

- Provides quick visual indication of contact status.

Built-in Mounting Feet

- Provides the secure installation inspectors require.

UL/cUL and CE Approved

- Accepted worldwide.

AS1, AS3, ASX, ASXP Series Sample Output

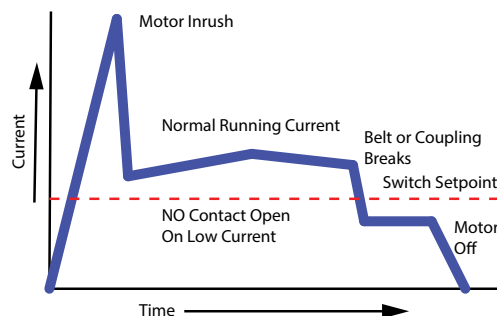
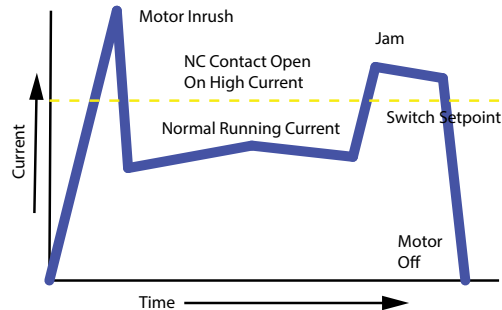

Current Sensing Switch Dimensions

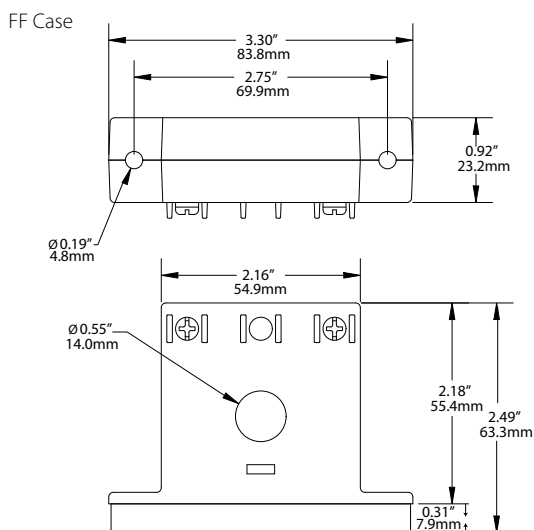

Note: The bottom 0.31" applies to -15 option only.

FT Case

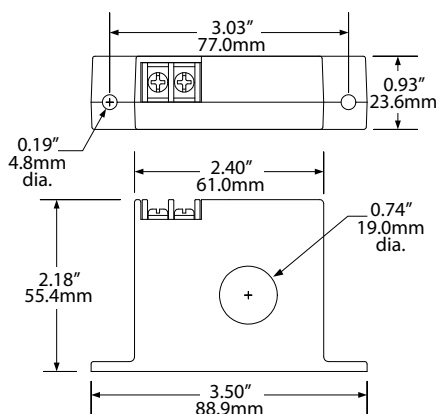

SP Case

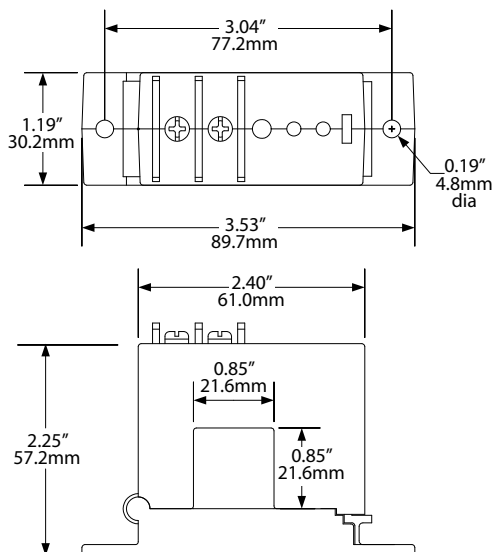

Current Sensing Switch Connections

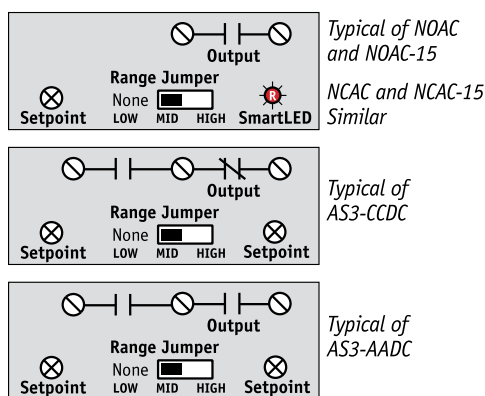

Note: Terminals are #6 screws. DC contacts are polarity sensitive.

Current Sensing Switch Specifications



Power Supply	None, self-powered												
Setpoint Range	<ul style="list-style-type: none"> Solid-core: 1–6, 6–40 & 40–175 A (adjustable) Split-core: 1.75–6, 6–40 & 40–200 A (adjustable) 												
Output Description	Isolated solid-state relay												
Output Rating	<ul style="list-style-type: none"> 1.0 A @ 240 VAC (standard AC units) 0.15 A @ 30 VDC (standard DC & multi-pole units) 15 A @ 120 VAC, 10 A @ 240 VAC (-15 option) 												
Off-state Leakage	<ul style="list-style-type: none"> NOAC: <10 μA NCAC: 2.5 mA AADC: <10 μA NODC: <10 μA NCDC: 1.4 mA CCDC: 0.3 mA (N.C. Terminal) 												
Response Time	2.5 sec. max.												
Time Delay	None												
Hysteresis	Low: 0.15 A, Mid: 0.3 A, High: 0.9 A												
Overload	<table border="1"> <tr> <td>RANGE</td> <td>6 SEC.</td> <td>1 SEC.</td> </tr> <tr> <td>• 1–6 A</td> <td>• 400 A</td> <td>• 600 A</td> </tr> <tr> <td>• 6–40 A</td> <td>• 500 A</td> <td>• 800 A</td> </tr> <tr> <td>• 40–175 A</td> <td>• 800 A</td> <td>• 1200 A</td> </tr> </table>	RANGE	6 SEC.	1 SEC.	• 1–6 A	• 400 A	• 600 A	• 6–40 A	• 500 A	• 800 A	• 40–175 A	• 800 A	• 1200 A
RANGE	6 SEC.	1 SEC.											
• 1–6 A	• 400 A	• 600 A											
• 6–40 A	• 500 A	• 800 A											
• 40–175 A	• 800 A	• 1200 A											
Isolation Voltage	UL listed to 1270 VAC, tested to 5 kV												
Frequency Range	6–100 Hz												
Case	UL94 V-0 Flammability Rated												
Environmental	-4 to 122°F (-20 to 50°C) 0–95% RH, non-condensing												
Listings	UL/cUL, CE												

*UL listing for -FF and -SP models only.



Current Sensing Switch Ordering Information

Sample Model Number: AS3-NOAC-FF-NL

Adjustable AC current sensing switch, normally open AC contacts, solid-core case, without indicating LED. (DIN rail adapters are included)



(1) Output Rating

NOAC	Normally Open, 1 A @ 240 VAC
NCAC	Normally Closed, 1 A @ 240 VAC
NODC	Normally Open, 0.15 A @ 30 VDC
NCDC	Normally Closed, 0.15 A @ 30 VDC
AADC	Dual, Normally Open, 30 VDC (-FF only)
CCDC	1 N.O., 1 N.C. Solid State, 0.15 A @ 30 VDC (-FF only)

(2) Case Style

FF	Solid-core, Front Term.
SP	Split-core
FT	Solid-core, Top Term.*

(3) Options

NL	No LED
03	3 A @ 120 VAC (-FT only, not UL listed)
15	15 A @ 120 VAC (-FF only)
	(Blank is standard)

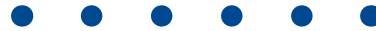

The AS3 series current sensing switches are the go-to models for a huge variety of applications. The models designed to control AC circuits can be manufactured with 1, 3 or 15 A capacities. The models with DC capabilities can be manufactured with dual contacts, adjustable between the selected ranges. NK Technologies’ original designs are refined to a wide range of application.

AS1 SERIES COMPACT CASE

AC Current Sensing Switches

The AS1 Series Compact Case Current Sensing Switches are compact and inexpensive. The easy-to-use ring slips onto the conductor to give a solid-state contact for indication of current flow. Ideal for use in control panels, or wherever confirmation of current flow is desired. AS1 Series-CC current sensing switches are a cost-effective way to detect live conductors and see current flow to fans, heaters, pumps, lighting or other AC powered devices.



Current Sensing Switch Applications

- Quick reporting of electric motor load status.
- Identify open heater circuit connection.
- Independent verification that the load is energized.
- Confirmation of operation for critical lighting or equipment.

Current Sensing Switch Features

Low Sensitivity Turn-on Point

- Detect currents as low as 0.5 A with a single conductor pass; eliminates the need to wrap conductors multiple times to increase sensitivity.

Reliable Solid-state Output

- No moving parts provides a nearly unlimited number of operations; powered from the monitored circuit.

Choice of Outputs

- Normally Open or Normally Closed connection. Connect the 24" long leads to a local controller or to a terminal block for remote operation.

Current Sensing Switch Dimensions

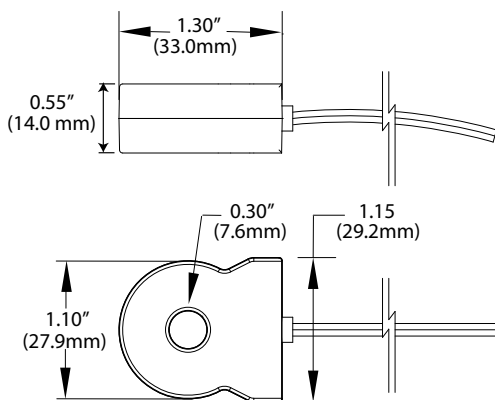

Current Sensing Switch Specifications



Power Supply	None, self-powered
Setpoint Range	0.5 A (factory set)
Output Description	Isolated solid-state relay
Output Rating	• 0.2 A @ 120 VAC/DC (N.O.) • 0.15 A @ 135 VAC/DC (N.C.)
Off-state Leakage	<10 μ A
Response Time	120 ms
Time Delay	None
Hysteresis	5%
Overload	6 sec. @ 500 A, 1 sec. @ 1000 A
Isolation Voltage	UL listed to 1270 VAC, tested to 5 KV
Frequency Range	50–400 Hz
Case	UL94 V-0 Flammability Rated
Environmental	-4 to 122°F (-20 to 50°C) 0–95% RH, non-condensing
Listings	UL /cUL, CE

Current Sensing Switch Ordering Information

Sample Model Number: AS1-NOU-CC

Adjustable AC current sensing switch, normally open, solid-core, compact case.

AS1 – (1) – (2) CC

(1) Output Rating

NOU	Normally Open
NCU	Normally Closed

(2) Case Style

CC	Compact Case
----	--------------

- For additional Application Examples, go to www.nktechnologies.com/applications



OEMs Test & Evaluation Units for OEMs
Free program expedites evaluation process. See page 3 for details.

ASL SERIES

AC Current Sensing Switches

The ASL Series Current Sensing Switches provide a current operated solid-state contact powered from the monitored circuit. The trip point adjustment uses a single turn potentiometer. By turning the adjustment arrow to the current magnitude needed, the installer can set the point where the output changes state when the monitored circuit is not energized. With the split-core case option, installation is just a matter of placing the sensor over the conductor. It couldn't be easier.

Features a Patent Pending Linear Setpoint Adjustment

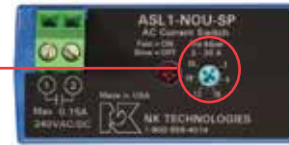

Current Sensing Switch Applications

AC Motor Loads

- Set a normally open contact over the normal running current level and it will open if the drive belt breaks or comes off the sheaves.
- Set a normally closed contact below the normal run current level and it will open on overload conditions.
- Monitor up to 150 A loads.

Critical Lighting Loads

- Monitor security lighting and water navigational indicators.

Heating Loads

- Receive independent verification that an element is working properly.
- Monitor drying and curing processes remotely.

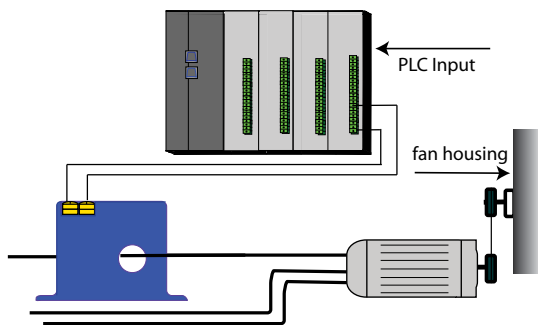

Motor current causes the solid-state contact to close, and if the coupling or drive belt breaks the current falls and the sensor output opens again.

Current Sensing Switch Features

Easily Established Contact Actuation Point

- Patented potentiometer setpoint selection (patent pending).
- Trip point indicated on the labeling.
- Trip point can be set with no load present, adding a large measure of safety.
- Two-second delay before contact action upon initial energization allows the output to ignore motor inrush current.

Isolation

- Output is magnetically isolated from the input for safety.
- Eliminates insertion losses, no added burden.

Solid-state Reliability

- No moving components for switching.
- No need for periodic maintenance or calibration.

Panel Mounted Solid- or Split-core Case

- Split-core case allows installation without disturbing existing wiring and can be mounted in any position. Either case can be attached to a panel, hung on the conductor or on a DIN rail adapter (included).*
- Both solid or split-core cases provide windows large enough for 150 A loads, non-contact design provides complete isolation between primary circuit and control circuitry.

No External Power Needed

- Sensor is powered from the monitored AC circuit.
- Choose normally open (closing on current increase) or normally closed (opening on current increase).
- Fast action contact reacts quicker than RTD, thermocouples, or bimetallic thermal elements.

*For information on the DIN rail accessories kit, see page 128.

OEMs

Test & Evaluation Units for OEMs

Free program expedites evaluation process. See page 3 for details.

Current Sensing Switch Dimensions

FF Case

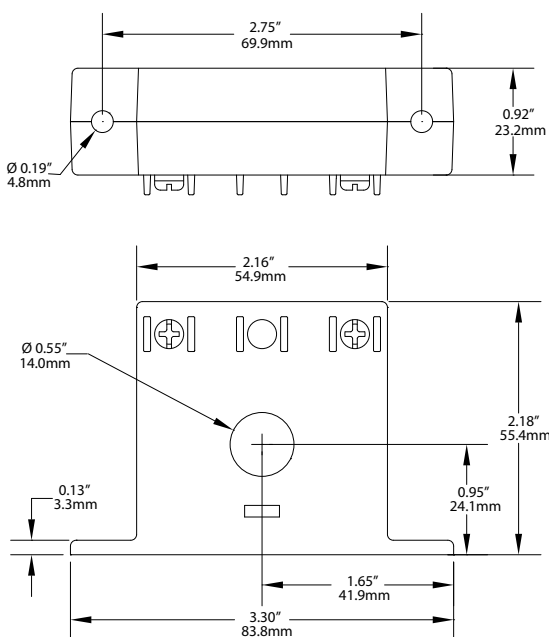

SP Case

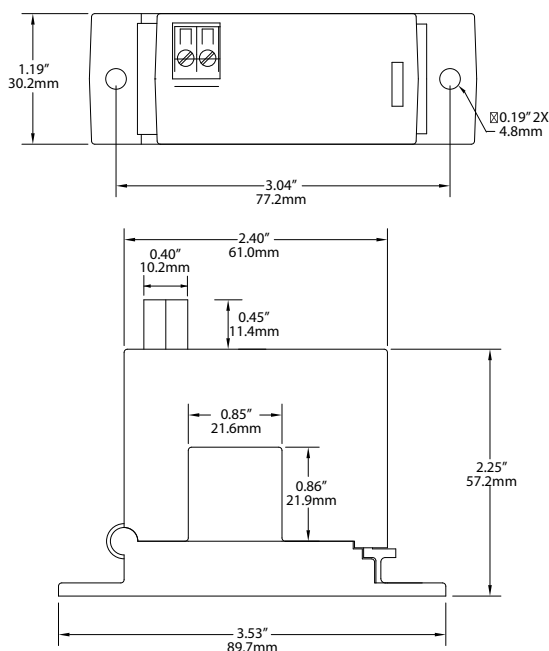

Current Sensing Switch Connections

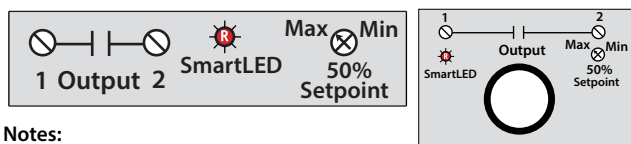

Notes:

- Zinc plated screw terminals solid-core case.
- Deadfront enclosed terminals split-core case.
- 12–22 AWG solid or stranded.
- Not polarity sensitive.

Current Sensing Switch Specifications



Power Supply	None, self-powered
Input Range	1–150 A (adjustable)
Output Description	Isolated solid-state relay (AC/DC)
Output Rating	<ul style="list-style-type: none"> • 150 mA @ 240 VAC/DC N.O. • 200 mA @ 135 VAC/DC N.C.
Response Time	100 ms
Time Delay	2 seconds on initial energization
Isolation Voltage	UL listed to 1270 VAC, tested to 5 KV
Frequency Range	10–100 Hz AC
Case	UL94 V-0 Flammability Rated
Environmental	<ul style="list-style-type: none"> -4 to 122°F (-20 to 50°C) 0–95% RH, non-condensing
Listings	UL/cUL, CE

Current Sensing Switch Output Type

Normally open universal AC or DC solid-state contact, 150 mA to 240 V (maximum load across output contact) or normally closed universal AC or DC solid-state contact, 200 mA to 135 V (maximum load across output contact).

Current Sensing Switch Ordering Information

Sample Model Number: ASL1-NOU-FF

Solid-core AC current sensing switch with single turn setpoint adjustment, Smart LED standard. (DIN rail adapters are included)

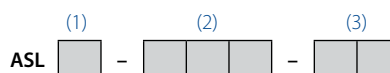

(1) Full Scale Range

1	1–10 A (solid-core) 2–20 A (split-core)
2	10–50 A (solid-core) 20–50 A (split-core)
3	50–100 A
4	100–150 A

(2) Output Type

NOU	Normally Open
NCU	Normally Closed

(3) Case Style

FF	Solid-core, front terminals
SP	Split-core



ASM SERIES

Self-calibrating Smart-Switches

The newly designed ASM Series Self-calibrating Smart-Switch is more accurate and easier to use than previous models. This Smart-Switch uses the actual load current to set the trip point. It takes just a couple of seconds of steady running conditions before the sensor locks onto the normal current level. The ASM Series is designed for overload, underload or operating window applications. Upon sensing an average operating current, the ASM self-learns and establishes a limit-alarm trip point based on 85–125% of normal current (overload/underload model only). Available in a solid- or split-core case.



Current Sensing Switch Applications

Conveyors (-OL Option)

- Detects jams and overloads.
- Interlocks multiple conveyor sections.

Electronic Proof of Flow (-UL Option)

- More reliable than electromechanical pressure or flow switches. No need for pipe or duct penetrations.

Pump Protection (-OU Option)

- Provides overload (jams) and underload (suction loss) indication.
- Interlocks multiple conveyor sections.

Current Sensing Switch Features

Self-powered and Self-calibrating

- Speeds startups, cuts installation costs.

Status Monitoring, Overload, and Operating Window Options

- Choose the operating style that matches your application.

Universal Output

- AC or DC compatibility with any automation system.

UL/cUL and CE Approved

- Accepted worldwide.

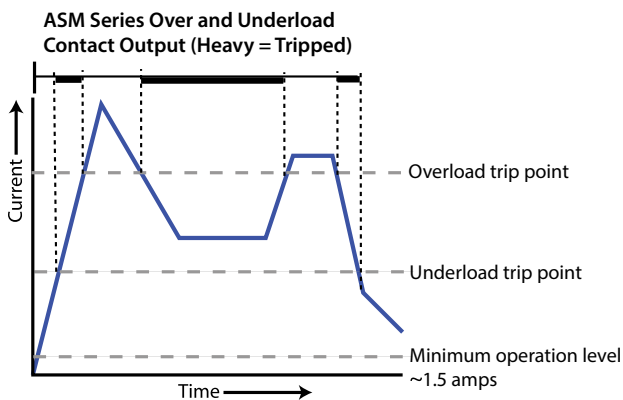

- For additional Application Examples, go to www.nktechnologies.com/applications

OEMs

Test & Evaluation Units for OEMs

Free program expedites evaluation process. See page 3 for details.

Current Sensing Switch Dimensions

FT Case

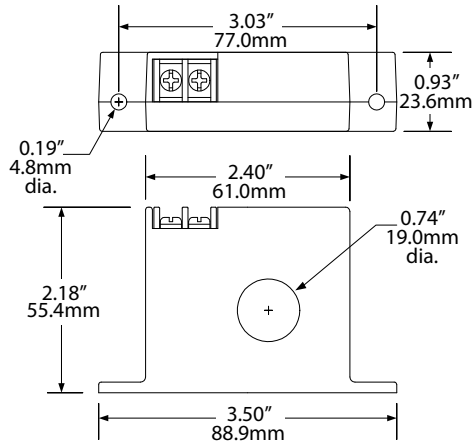

SP Case

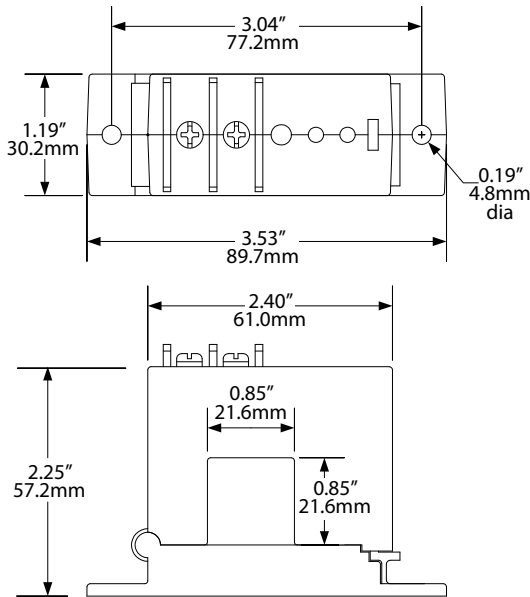

Current Sensing Switch Specifications



Power Supply	None, self-powered
Setpoint Range	• Solid-core: 1.5 – 150 A • Split-core: 2.8 – 150 A (self-calibrating)
Output Description	Isolated solid-state relay
Setpoint Calibration	Output changes with AC current between 85% and 125% of normal running current
Output Rating	• N.O. Version: 0.30 A @ 135 VAC or VDC • N.C. Version: 0.30 A @ 135 VAC/VDC • Not polarity sensitive
Off-state Leakage	<10 μ A
Response Time	200 ms
Time Delay	None
Hysteresis	5%
Overload	500 A @ 6 sec., 1000 A @ 1 sec.
Isolation Voltage	UL listed to 1270 VAC, tested to 5 KV
Frequency Range	6–100 Hz
Case	UL94 V-0 Flammability Rated
Environmental	-4 to 122°F (-20 to 50°C) 0–95% RH, non-condensing
Listings	UL/cUL, CE

Current Sensing Switches

Current Sensing Switch Ordering Information

Sample Model Number: ASM-NOU-OL-SP
AC current sensing switch, normally open, self-calibrating overload operation in a split-core case. (DIN rail adapters are included)

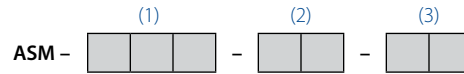

(1) Output Rating

NOU	Normally Open
NCU	Normally Closed

(2) Operation

OL	Overload
UL	Underload
OU	Over/underload

(3) Case Style

FT	Solid-core, top terminals
SP	Split-core



ASC SERIES

Factory-calibrated Current Operated Switches

ASC Series Current Operated Switches are precision calibrated at the factory per customers' specifications and guaranteed within 1% accuracy. Because the switch is factory calibrated eliminating the need to turn the potentiometer to the correct position in the field, installation time is substantially reduced resulting in a significant cost savings. The ASC combines a current transformer, signal conditioner and limit alarm into a single package for use in status monitoring or proof of operation applications and is perfect for OEM applications where the need for a limit alarm is required. Available in a solid-core or a split-core case to maximize ease of installation.

Current Sensing Switch Applications

Electronic Proof of Flow

- Current operated switches eliminate the need for multiple pipe or duct penetrations and are more reliable than electromechanical pressure or flow switches.

Conveyors

- Detects jams and overloads.
- Interlocks multiple conveyor sections.

Lighting Circuits

- Easier to install and more accurate than photocells.

Electrical Heaters

- Faster response than temperature sensors.

Air Handling Fan Protection

Factory-set trip points are ideal when there are several loads, all using the same motor to drive the fan blades.

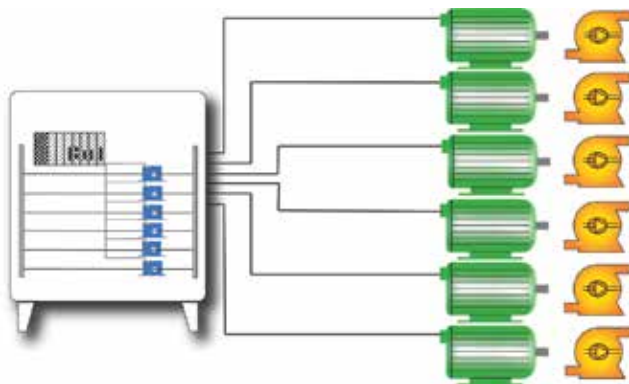

- For additional Application Examples, go to www.nktechnologies.com/applications

OEMs

Test & Evaluation Units for OEMs

Free program expedites evaluation process. See page 3 for details.

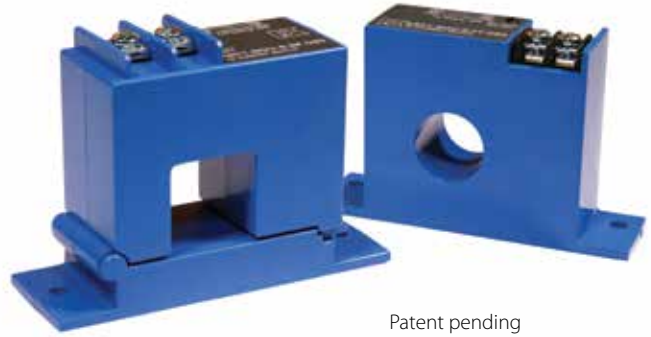

Patent pending

Current Sensing Switch Features

Universal Output

- N.O. or N.C. solid-state switch for control circuits up to 135 VAC/DC.
- Compatible with most automation systems.

Self-powered

- Cuts installation and operating costs.

Precision-calibrated Factory Set Trip Point

- Speeds startup.
- Improves safety.

Solid- or Split-core Case

- Versions tailored for each installation.

LED Indication

- Provides quick visual indication of contact status.

Built-in Mounting Feet

- Simple, two-screw panel mounting or attach with DIN rail adapters (included).*

Designed for UL/cUL and CE Approval

- Accepted worldwide.

*For information on the DIN rail accessories kit, see page 128.

Current Sensing Switch Dimensions

FT Case

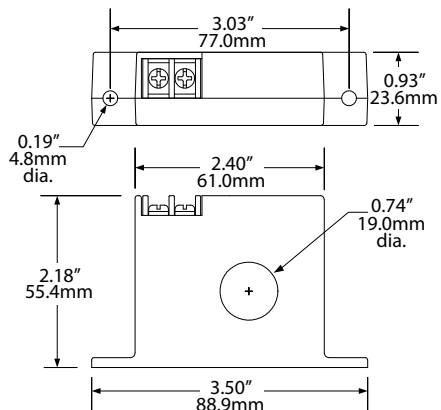

SP Case

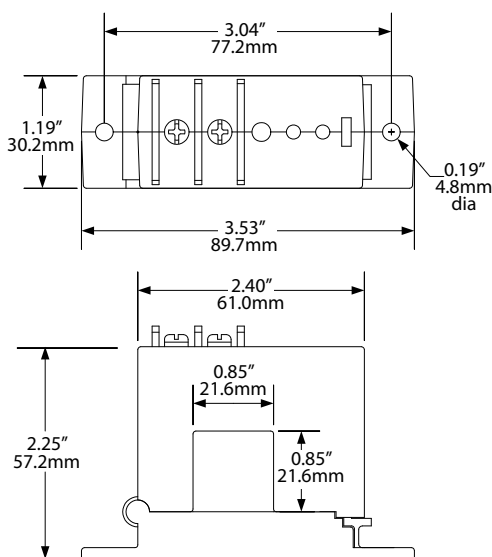

Current Sensing Switch Connections

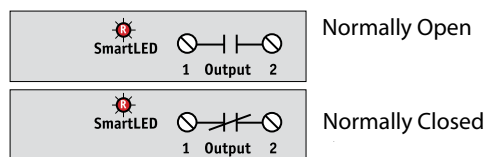

Current Sensing Switch Specifications

Power Supply	None, self-powered
Setpoint Range	• Solid-core: 2–150 amps (factory set) • Split-core: 3–150 amps (factory set)
Output Description	Isolated solid-state relay
Output Rating	• N.O. Version: 0.3 A @ 135 VAC or VDC • N.C. Version: 0.3 A @ 135 VAC or VDC • Not polarity sensitive
Off-state Leakage	<10 µA
Response Time	120 ms
Time Delay	None
Hysteresis	5%
Overload	400 A @ 6 sec., 1000 A @ 1 sec.
Isolation Voltage	UL listed to 1270 VAC, tested to 5 KV
Case	UL94 V-0 Flammability Rated
Environmental	-4 to 122°F (-20 to 50°C) 0–95% RH, non-condensing
Listings	Designed for UL/cUL and CE approval

Ordering Information

Sample Model Number: ASC-NOU-6-SP-090
 Factory set AC current operated switch, normally open, 60 Hz frequency, split-core case, 90 A trip point. (DIN rail adapters are included)

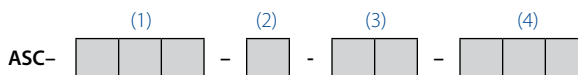

(1) Output Rating

NOU	Normally Open
NCU	Normally Closed

(2) Primary Circuit Frequency

6	60 Hz
5	50 Hz

(3) Case Style

FT	Solid-core, top terminal
SP	Split-core

(4) Factory Set Trip Point

002 to 150	Solid-core model factory set trip point in amps.
003 to 150	Split-core model factory set trip point in amps.



ASD SERIES

Current Sensing Switches

ASD series sensors provide a limit alarm contact with the easiest adjustment method ever designed. The single turn potentiometer, allows the trip point to be set before the sensor is installed, or before the monitored circuit is energized. The LED display provides a quick visual indication of where the contact changes.



Features a single turn potentiometer and LED display.

Current Sensing Switch Applications

Electronic Proof of Operation

- Current operated switches eliminate the need for multiple pipe or duct penetrations and are more reliable than electromechanical pressure or flow switches.

Conveyors

- Detects jams and overloads.
- Interlocks multiple conveyor sections.

Pump Control

- Output contact is adjusted so it is closed during normal operation, opening if the pump runs dry or there is a loss of head pressure for any reason.

Cooling Towers

- Monitor for overcurrent conditions caused by open duct access doors or undercurrent from a broken drive belt or coupling.

Conveyor Protection

If the conveyor jams, the solid-state contact opens to stop the infeed or drive motor.

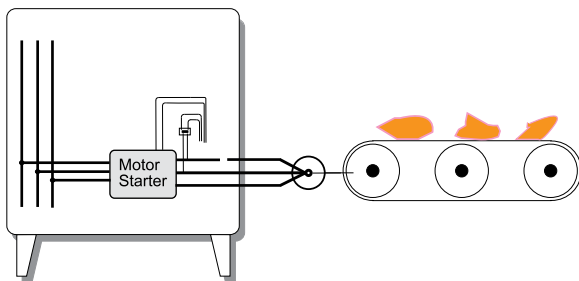

- For additional Application Examples, go to www.nktechnologies.com/applications

Current Sensing Switch Features

Solid-state Output

- N.O. or N.C. solid-state switch for control circuits up to 240 VAC.
- Compatible with most automation systems.

External Powered

- Allows for higher accuracy.

Easily Adjustable and Precise Setpoint

- Speeds startup.
- Improves the safety by allowing the trip point adjustment with no power through the sensing window.

LED Display

- Provides quick visual indication of where the contact changes. When current exceeds the setpoint, the display flashes on and off.
- Easiest and most accurate setpoint adjustment available.

Built-in Mounting Feet

- Simple, two-screw panel mounting or attach with DIN rail adapters (included).*

Designed for UL/cUL and CE Approval

- Accepted worldwide.

*For information on the DIN rail accessories kit, see page 128.

OEMs

Test & Evaluation Units for OEMs

Free program expedites evaluation process. See page 3 for details.

Current Sensing Switch Dimensions

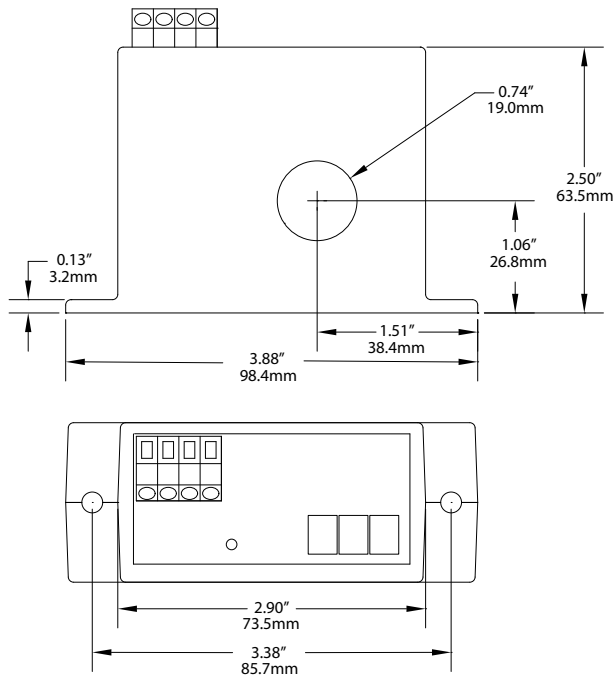

Current Sensing Switch Connections

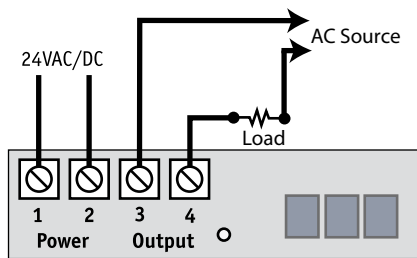

Display shows trip point in amps so 15 A displays 015.

Current Sensing Switch Specifications

Power Supply	24 VAC/DC (18–28 V)
Power Consumption	70 mA max.
Setpoint Range	• ASD1: 1–50 A (adjustable) • ASD2: 4–200 A (adjustable)
Output Description	Isolated solid-state relay
Output Rating	Max.: 1.0 A @ 240 VAC
Off-state Leakage	• <10 μ A normally open • 2.5 mA normally closed
Response Time	120 ms max.
Time Delay	None
Hysteresis	5%
Isolation Voltage	Tested to 5 kV
Frequency Range	6–100 Hz
Case	UL94 V-0 Flammability Rated
Environmental	-4 to 122°F (-20 to 50°C) 0–95% RH, non-condensing
Listings	Designed for UL/cUL and CE approval

Ordering Information

Sample Model Number: ASD1-NOAC-24U-FL

Adjustable AC current operated switch, normally open, solid-core case. (DIN rail adapters are included)



(1) Range

1	1–50 A switch adjustment
2	4–200 A switch adjustment

(2) Output Contact

NOAC	Normally Open, closes on current rise, AC control only
NCAC	Normally Closed, opens on current rise, AC control only

(3) Power Supply

24U	24 VAC or DC
-----	--------------

(4) Case Style

FL	Solid-core
----	------------



ASO SERIES

Current Sensing Switches

ASO Series Low-current Current Sensing Switches are specialized current sensing switches that combine an ultra-sensitive current transformer and signal conditioning electronics into a single package for sensing AC current from 3–350 mA. Useful for signal or lamp status monitoring, detecting low level fault currents or fan status proofing, the ASO Series features solid-state outputs and jumper-selectable ranges, which make it a versatile choice for low-current status indication applications.



Current Sensing Switch Applications

Fan Monitoring

- Fan status in heating and drying applications.
- Identify lamp outages or other malfunctions through changes in current consumption.

Fractional HP Motors

- Ideal for monitoring small motors used in critical applications, for example, fan status proofing on a crucial cooling fan.

LED Lamp Operation

- Switch can detect LED light sources drawing less than one half watt at 120 VAC.

Current Sensing Switch Features

Wide Range of Output Options

- Dependable, solid-state relay N.O. or N.C. contacts rated at 240 VAC or 30 VDC.
- Compatible with most automation controllers.

Isolated Inputs and Outputs

- Inductive sensing eliminates insertion loads on monitored circuits, effectively isolating it from the unit.
- Isolated outputs simplify wiring and enhance safety.

Adjustable Setpoints

- Setpoints are field-adjustable from 3 mA to 350 mA, speeding installation and allowing for tailored applications.

UL/cUL and CE Approved

- Accepted worldwide.

Status Alarming

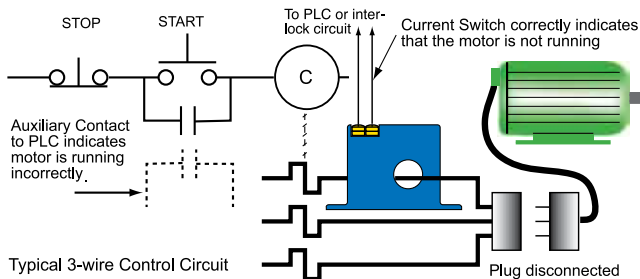

- For additional Application Examples, go to www.nktechnologies.com/applications

OEMs

Test & Evaluation Units for OEMs

Free program expedites evaluation process. See page 3 for details.

Current Sensing Switch Dimensions

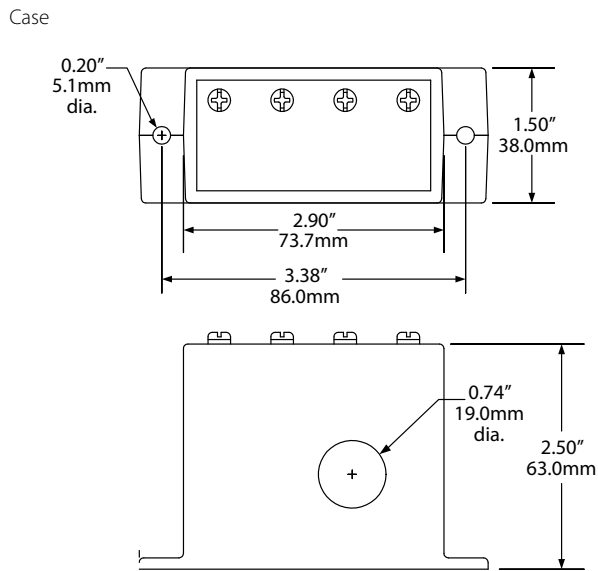

Current Sensing Switch Specifications



Power Supply	<ul style="list-style-type: none"> • 120 VAC (96–144 V) • 24 VAC/DC (19–29 V)
Power Consumption	2.5 VA
Setpoint Range	<ul style="list-style-type: none"> • Low Range: 3–15 mA (adjustable) • High Range: 15–350 (adjustable)
Input	10 A max.
Output Rating	<ul style="list-style-type: none"> • AC Version: 1 A @ 240 VAC • DC Version: 0.15 A @ 30 VDC
Response Time	<ul style="list-style-type: none"> • 150 ms @ 5% above setpoint • 100 ms @ 50% above setpoint
Time Delay	None
Hysteresis	<5%
Overload	10 A continuous
Isolation Voltage	UL listed to 1270 VAC, tested to 5 KV
Frequency Range	50–400 Hz
Case	UL94 V-0 Flammability Rated
Environmental	-4 to 122°F (-20 to 50°C) 0–95% RH, non-condensing
Listings	UL/cUL (most models), CE

Current Sensing Switches

Current Sensing Switch Connections

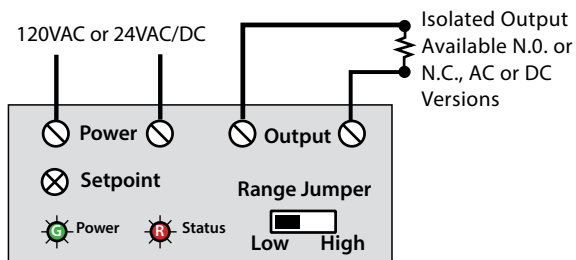

Notes:
 Terminals are #6 screws.
 Use up to 14 AWG solid or stranded.
 Power connections are not polarity sensitive.
 DC output connections are polarity sensitive.

Current Sensing Switch Ordering Information

Sample Model Number: AS0-NODC-120

Ultra low current sensing switch, normally open solid-state DC output and 120 VAC power supply. (DIN rail adapters are included)

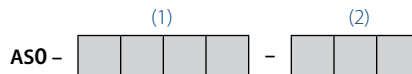

(1) Output Type

NCAC	Normally Closed, 1 A @ 240 VAC
NOAC	Normally Open, 1 A @ 240 VAC
NCDC	Normally Closed, 0.15 A @ 30 VDC
NODC	Normally Open, 0.15 A @ 30 VDC

(2) Power Supply

24U	24 VAC/DC
120	120 VAC



ASX SERIES

Current Sensing Switches

ASX Series Current Sensing Switches are high performance current sensing switches with field-adjustable time delay to help minimize nuisance trips during startup and operation. Designed for motor status applications where setpoint accuracy and repeatability are critical, the ASX Series offers a linear setpoint characteristic and constant hysteresis. Standard features include self-powering, jumper-selectable ranges and a choice of outputs and cases.



Current Sensing Switch Applications

Motor Protection

- Serves as an electronic proof-of-operation; detects current draw changes in motors when they encounter problems such as pumps running dry or pending bearing failure.
- Non-intrusive, less expensive to install than differential pressure flow sensors or thermal switches.
- Much quicker response time than Class 10 overload switches.

High Inrush or Temporary Overload Current

- Adjustable startup/delay timer allows 0.2–15 second delay to eliminate nuisance trips from high inrush or short overload conditions.

Isolated Alarm System Interfacing

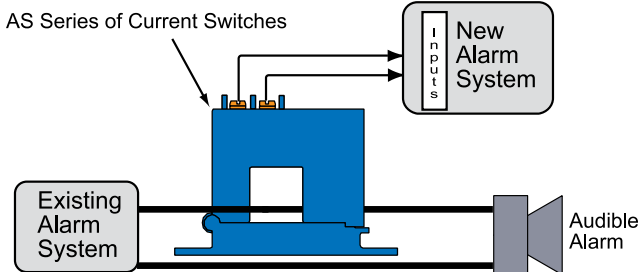

- For additional Application Examples, go to www.nktechnologies.com/applications

Current Sensing Switch Features

Adjustable Startup/Delay Timer

- Field-adjustable from 0.12 to 15 seconds to eliminate nuisance alarms due to startup inrush or temporary overcurrent conditions.

Choice of N.O./N.C. AC or Universal Outputs

- Contact ratings of 1.0 A @ 240 VAC or universal outputs of 0.15 A @ 240 VAC/DC (N.O. models) and 0.2 A @ 135 VAC/DC (N.C. models) for use with most standard motor control systems.

Improved Ease of Installation and Use

- 1.0 A AC rating eliminates need for time delay relay.
- Self-powered, split-core models simplify installation.
- Status LED provides visual indication of setpoint trip and contact action.

Industrial Grade Performance

- Constant hysteresis, linear response characteristics enhance setpoint accuracy.

UL/cUL Approved, CE Approval Pending

- Accepted worldwide.

OEMs Test & Evaluation Units for OEMs
Free program expedites evaluation process. See page 3 for details.



Current Sensing Switch Dimensions

FT Case

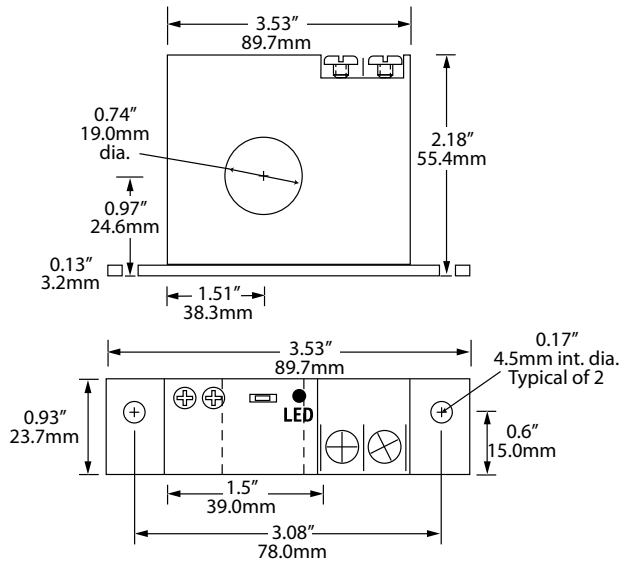

SP Case

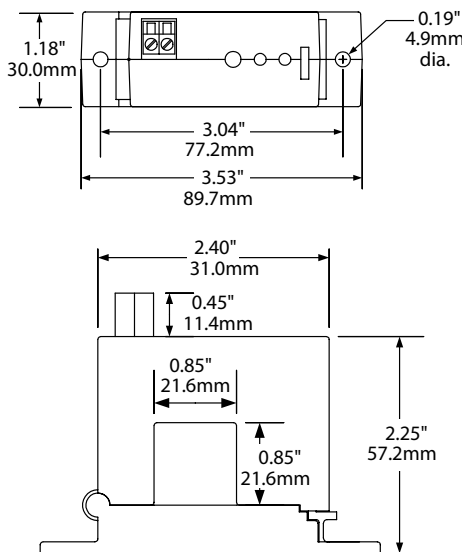

Current Sensing Switch Connections

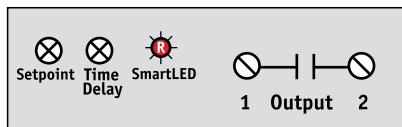

Current Sensing Switch Specifications

Power Supply	None, self-powered
Setpoint Range	1.5–12 A, 12–55 A, 50–200 A (adjustable)
Output Description	Isolated solid-state relay
Output Rating	<ul style="list-style-type: none"> • NOAC/NCAC: 1 A @ 240 VAC • NOU: 0.15 A @ 240 VAC or VDC • NCU: 0.2 A @ 135 VAC or VDC
Off-state Leakage	NOU, NCU & NOAC versions: <10 micro A NCAC versions: 2.5 mA
Response Time	0.12 – 15 sec.
Time Delay	Adjustable
Hysteresis	5%
Overload	<ul style="list-style-type: none"> • 1.5–12 A range: 600 A max. • 12–55 A range: 800 A max. • 50–200 A range: 1200 A max.
Isolation Voltage	UL listed to 1270 VAC, tested to 5 kV
Frequency Range	50–100 Hz
Case	UL94 V-0 Flammability Rated
Environmental	-4 to 122°F (-20 to 50°C) 0–95% RH, non-condensing
Listings	UL/cUL*, CE pending

*NOAC/NCAC-FT models are not UL listed.

Current Sensing Switch Ordering Information

Sample Model Number: ASX-NOAC-SP

Current sensing switch with adjustable time delay, N.O. 1.0 A @ 240 VAC output, jumper-selectable input ranges, split-core case. (DIN rail adapters are included)

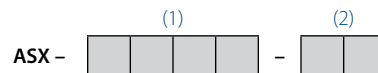

(1) Output Type

NOAC	Normally Open, 1 A @ 240 VAC
NCAC	Normally Closed, 1 A @ 240 VAC
NOU	Normally Open, 0.15 A @ 240 VAC/DC
NCU	Normally Closed, 0.2 A @ 135 VAC/DC

(2) Case Style

FT	Solid-core
SP	Split-core

Current Sensing Switches



ASP-FD SERIES

Current Operated Switch

ASP-FD Series sensors allow two separate trip points to detect over current and undercurrent conditions. The sensor outputs are dual, single-pole, double-throw relays, so they can control either AC or DC circuits and provide an alarm if the monitored circuit draws too little or too much current. One sensor means less installation time and less panel space required. The Status LEDs indicate if the monitored circuit current is under or over each of the trip points.



Current Switch Applications

Electronic Proof of Operation

- Current operated switches eliminate the need for multiple pipe or duct penetrations and are more reliable than electromechanical pressure or flow switches.

Conveyors

- Detect jams and overloads.
- Interlocks with safety equipment.

Pump Control

- Output contact is adjusted so it is closed during normal operation, opening if the pump runs dry or there is a loss of head pressure for any reason.

Cooling Towers

- Monitor for over current conditions caused by open duct access doors or under current from a broken drive belt or coupling.

Pump Protection

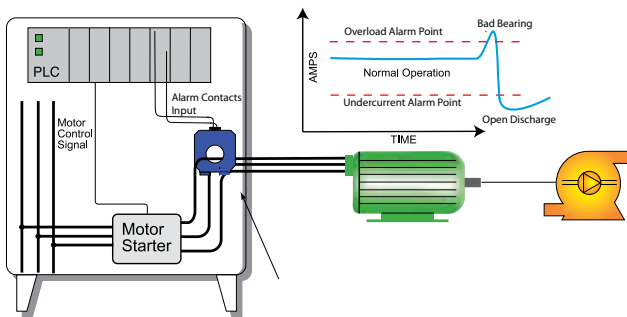

Pumps draw more current when there are mechanical problems like seizing bearings or obstructed impellers, and draw less current when the intake suction is blocked or the discharge is not connected.

Current Switch Features

Two Electromechanical Relay Outputs

- Access to both the N.O. and N.C. contacts at independent setpoints.
- Because relay outputs are floating they can be wired in parallel or in series for a two-wire over/under switch.

Externally Powered

- Allows for higher accuracy.

Easily Adjustable and Precise Setpoint

- Single turn potentiometer: point the arrow at the current value where you need the output to change, and you are done.
- Improves the safety by allowing the trip point adjustment with no power through the sensing window.
- Easiest set point adjustment available.

Solid-core Case

- Sensing window provides ample space for bus bar, single or multiple conductors.

Mounting Options

- Sensor can snap onto a DIN rail or be mounted to a back panel with screws.
- "Finger-safe" terminals are located on the sensor top.

Designed for UL, CUL and CE Approval

- Accepted around the world.

OEMs Test & Evaluation Units for OEMs
Free program expedites evaluation process. See page 3 for details.

Current Switch Dimensions

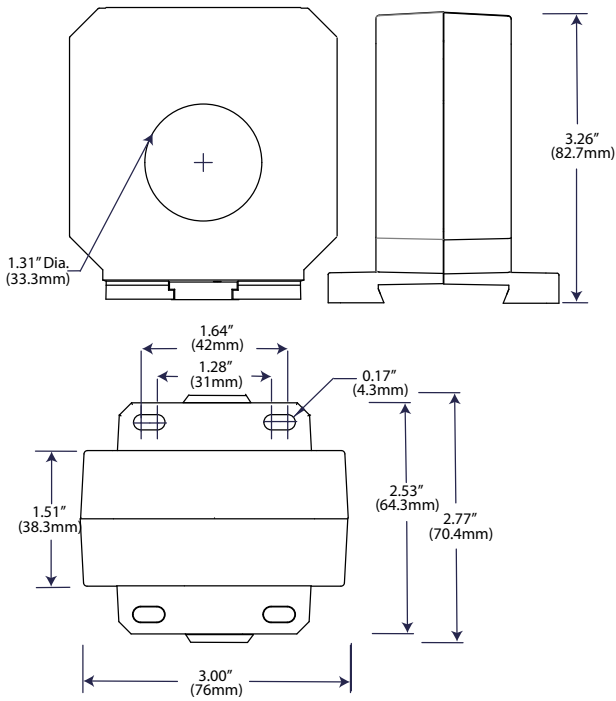

Current Switch Specifications

Power Supply	24 VAC/DC (<2VA consumption)
Output	Dual Single Pole, Double Throw Relays
Output Rating	Maximums: 1.0 A up to 125 VAC 2A to 30 VDC
Off-State Leakage	None
Response Time	40-120 ms
Setpoint Ranges	ASP1: 1–20 A ASP2: 2–35 A ASP3: 4–65 A ASP4: 8–120 A ASP5: 15–220 A ASP6: 25–400 A
Hysteresis	4% of range
Overload	6 sec: 3x range 1 sec: 5 x range
Isolation Voltage	Tested to 5000 VAC
Frequency Range	40–65Hz
Case	UL94 V0 Flammability Rated
Environmental	-4 to 122°F (-20 to 50°C) 0–95% RH, non-condensing
Listings	Designed to meet UL 508 Industrial Control Equipment (USA & Canada)

Current Switch Connections

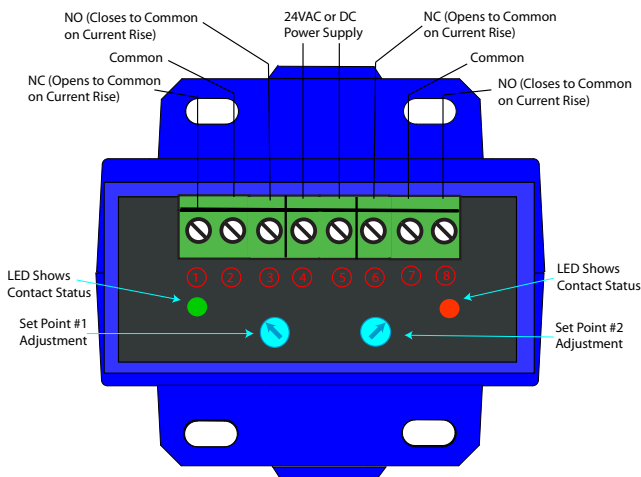

Ordering Information

Sample Model Number: ASP1-DPT-24U-FD
Dual adjustable AC current operated relay, 1–20 A range, 24 VAC or DC power supply, solid-core case.



(1) Range

1	1–20 A
2	2–35 A
3	4–65 A
4	8–120 A
5	15–220 A
6	25–400 A

(3) Output Contact

DPT	Two independent SPDT Relays
-----	-----------------------------

(4) Power Supply

24U	24 VAC or DC
-----	--------------

(3) Case Style

FD	Solid-core, DIN rail or panel mounting
----	--



ASXP SERIES

Current Sensing Switches

ASXP Series Current Sensing Switches are powered versions of our popular current switches with integral time delay. A fixed two-second delay upon initial energization of monitored load minimizes nuisance alarms during startup and operation in motor or heater status applications. After startup a separate 0–20 second delay can be set. For use with 24 VAC/DC or 120 VAC supplies, this high performance product offers OEM-caliber accuracy, precision tolerances, low hysteresis and an operation range between 40 and 100 Hz. Available with status LED and solid-core case as standard.



Current Sensing Switch Applications

Motor Protection

- Serves as an electronic proof-of-operation; detects current draw changes in motors when they encounter problems such as pumps running dry or impending bearing failure.
- Non-intrusive, less expensive to install than differential pressure flow sensors or thermal switches.
- Much quicker response time than Class 10 overload switches.

High Inrush or Temporary Overload Current

- Factory-set two-second delay on startup eliminates nuisance trips from high inrush or short overload conditions. After startup, a second 0–20 second user-adjustable delay is available.

Safety Interlocks

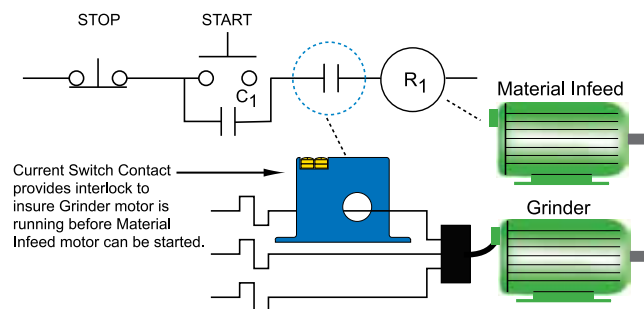

- For additional Application Examples, go to www.nktechnologies.com/applications

Current Sensing Switch Features

Fixed Startup/Delay Timer

- Factory-calibrated trip timer set to 2 seconds to eliminate nuisance alarms due to startup inrush or temporary overcurrent conditions.

Form C Electromechanical Relay Output

- Contact rating of 1 A, up to 120 VAC, provides adequate switching capacity for use with most motor control systems.

Improved Ease of Installation and Use

- Eliminates need for separate time delay relay.
- Choice of 24 VAC/DC or 120 VAC supply models.
- LED provides indication of trip point contact status.
- Setpoint adjustable from 1–80 A.

Industrial Grade Performance

- Repeatable performance, precise time delay setpoint, constant hysteresis and linear trip point adjustment.

UL/cUL and CE Approved

- Accepted worldwide.

OEMs

Test & Evaluation Units for OEMs

Free program expedites evaluation process. See page 3 for details.

Current Sensing Switch Dimensions

FL Case

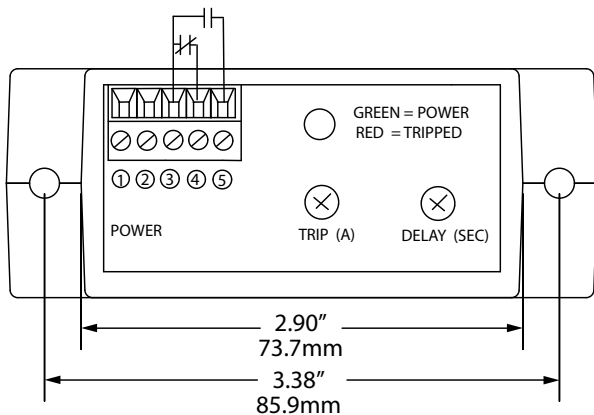
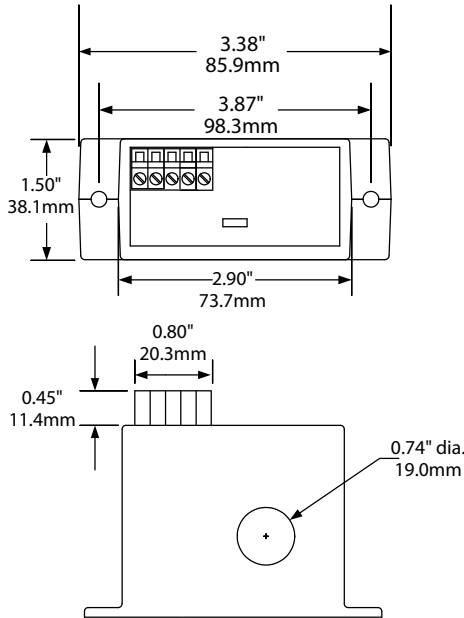

Terminal Identification:
 1 & 2 - Power Connection
 3 - Output Common
 4 - Output Normally Closed Contact
 5 - Output Normally Open Contact

Use up to 14 AWG copper wire.
 Tighten terminals 4.4 to 5.3 lbs.- in. torque.

Current Sensing Switch Specifications



Power Supply	• 120 VAC (108–136 V) • 24 VAC/DC (22–26 V)
Power Consumption	<2 VA
Setpoint Range	• ASXP1: 1–20 A (adjustable) • ASXP2: 20–50 A (adjustable) • ASXP3: 50–80 A (adjustable)
Output Description	Electromechanical SPDT relay
Output Rating	1 A @ 120 VAC; 2 A @ 30 VDC
Time Delay	2.0 sec. (fixed on startup) 0–20 sec. (adjustable after startup)
Hysteresis	5%
Isolation Voltage	UL listed to 1270 VAC, tested to 5 kV
Frequency Range	40–100 Hz
Case	UL94 V-0 Flammability Rated
Environmental	-4 to 122°F (-20 to 50°C) 0–95% RH, non-condensing
Listings	UL/cUL, CE

Current Sensing Switches

Current Sensing Switch Ordering Information

Sample Model Number: ASXP1-SDT-120-FL

AC current sensing switch, fixed 2 sec. delay, SPDT 1 A, 120 VAC output, 120 VAC/DC supply, solid-core case. (DIN rail adapters are included)



(1) Input Range

1	1–20 A
2	20–50 A
3	50–80 A

(2) Output Type

SDT	SPDT 1 A @ 120 VAC
-----	--------------------

(3) Power Supply

24U	24 VAC/DC
120	120 VAC

(4) Case Style

FL	Solid-core
----	------------

Current Sensing Switch Connections

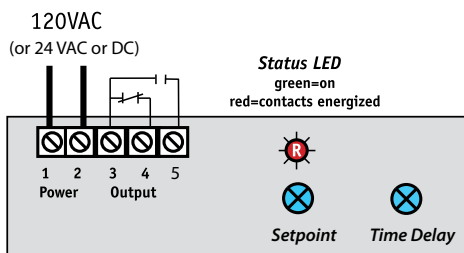

ASXP-MS SERIES

Current Sensing Switches

ASXP-MS Series Current Switches combine a current transformer and signal conditioner into a single package. The large, easy-to-install split-core design allows for installation over existing conductors without the need to disconnect the load, even in applications where there are multiple conductors per phase. For new installations, the installation is just as easy. Just remove the top portion of the sensing ring, place the conductors inside, and snap the top back in place. The switch output is powered from the primary circuit, and the setpoint is adjustable between a very wide range. The solid-state contact provides a trouble free, long lasting and very durable alarm or interlock, improving safety and overall system reliability.

Current Switch Applications

Monitor Large Machines

- Detect over or undercurrent conditions before they cause break downs, or interlock one process with another.

Water Delivery and Treatment

- Detect open discharge lines.
- Sense clogged filters or blocked intake to pumps.

Generators

- Shed noncritical loads when demand reaches a set level.

Crusher Monitoring

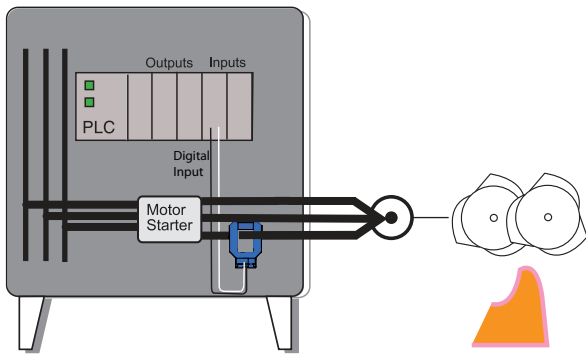

If the crusher drive draws too much current, the infeed belt can be stopped automatically, allowing the crusher to clear before restarting. The ASXP-MS also has a set of relay contacts for alarm of over or undercurrent conditions.

- For additional Application Examples, go to www.nktechnologies.com/applications

OEMs Test & Evaluation Units for OEMs
Free program expedites evaluation process. See page 3 for details.



Current Switch Features

Electromechanical Relay Output

- Provides both normally open and normally closed contacts.
- Compatible with most automation and control systems.

Externally Powered

- Provides a choice of failsafe* or standard operation.

Simple Field Setpoint Adjustment

- Single turn potentiometer with setpoint shown on label.
- Adjustable start delay to bypass inrush current.

Split-core Case

- Sensing window provides ample space for bus bar, single or multiple conductors.

DIN Rail** or Panel Mounted Case

- Simply snap onto DIN rail or attach with screws to a panel for secure mounting.

UL/cUL and CE Approved

- Accepted worldwide.

*For a description of failsafe operation, see the installation instructions.

**For information on the DIN rail accessories kit, see page 128.

Current Switch Connections

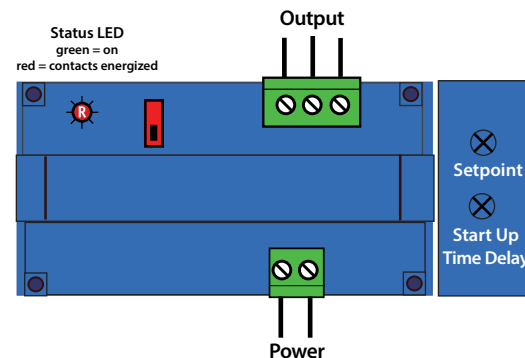

Current Switch Dimensions

MS Case

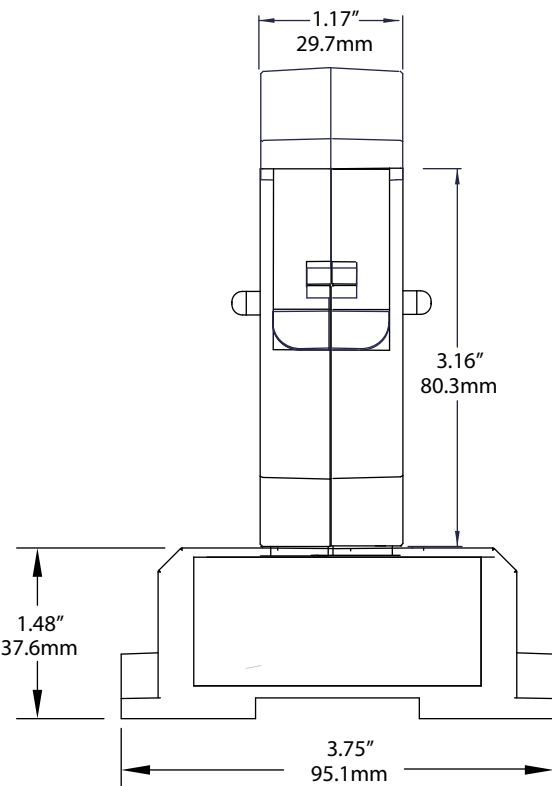
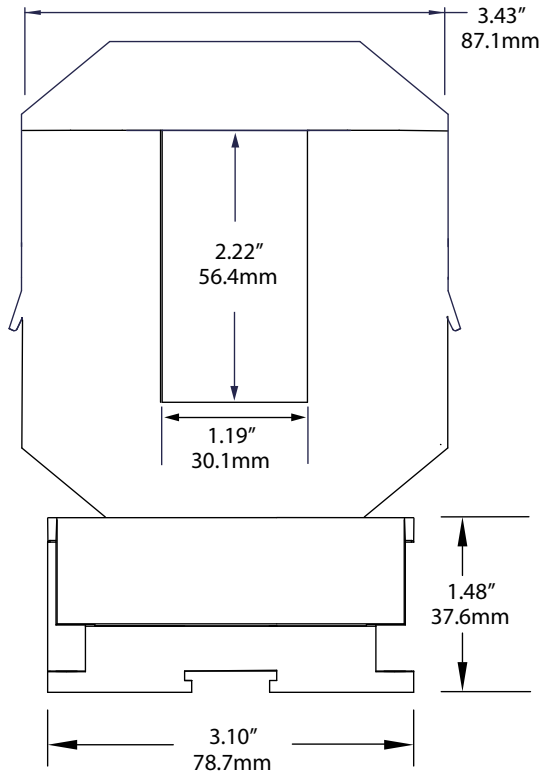

Note: Drawings are not to scale.

Current Switch Specifications



Power Supply	120 VAC or 24 VAC/DC (22–36 V)
Power Consumption	<4 VA
Input Range	<ul style="list-style-type: none"> • 2: 50–200 A • 4: 100–400 A • 6: 150–600 A • 8: 200–800 A
Output Description	Electromechanical SPDT relay
Output Rating	1 A @ 120 VAC, 2 A @ 30 VDC max.
Indicating Bi-color LED	Green: Power on, current within range Red: Power on, current over setpoint Off: Power off or current less than 20% of range
Output Operation	Selectable: Normal or failsafe*
Response Time	900 ms max.
Time Delay	0.5 to 16 sec. (adjustable)
Hysteresis	5%
Isolation Voltage	UL listed to 1270 VAC, tested to 5 KV
Frequency Range	6–100 Hz
Case	UL94 V-0 Flammability Rated
Environmental	-4 to 122°F (-20 to 50°C) 0–95% RH, non-condensing
Listings	UL/cUL, CE

*For a description of failsafe operation, see the installation instructions.

Ordering Information

Sample Model Number: AXSP8-SDT-120-MS
 AC current switch, 200–800 A range, SPDT relay output, 120 VAC powered, medium split-core case, DIN rail mounting.



(1) Range

2	50–200 A
4	100–400 A
6	150–600 A
8	200–800 A

(3) Output Type

SDT	Single pole, double throw relay
-----	---------------------------------

(4) Power Supply

24U	24 VAC/DC
120	120 VAC

(3) Case Style

MS	Split-core, base terminals, DIN rail mounting
----	---

Current Sensing Switches



ASXP-LS SERIES

Current Sensing Switches

ASXP-LS Series Current Switches combine a current transformer and signal conditioner into a single package. The large, easy-to-install, split-core design allows for installation over existing conductors without the need to disconnect the load, even in applications where there are multiple conductors per phase. For new installations, the installation is just as easy. Just remove the top portion of the sensing ring, place the conductors inside, and snap the top back in place. The switch output is externally powered, and the setpoint is adjustable between a very wide range. The mechanical relay contact provides a trouble free, long lasting, and very durable alarm or interlock, improving safety and overall system reliability.

Current Sensing Switch Applications

Monitor Large Machines

- Detect over or undercurrent conditions before they cause break downs, or interlock one process with another.

Water Delivery and Treatment

- Detect open discharge lines.
- Sense clogged filters or blocked intake to pumps.

Generators

- Shed noncritical loads when demand reaches a set level.

Interlock Infeed Conveyor with Main Crusher

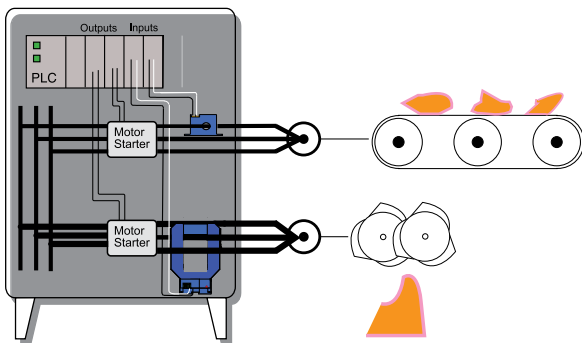

For additional Application Examples, go to www.nktechnologies.com/applications



Current Sensing Switch Features

Electromechanical Relay Output

- Provides both normally open and normally closed contacts.
- Compatible with most automation and control systems.

Externally Powered

- Provides a choice of failsafe* or standard operation.

Simple Field Setpoint Adjustment

- Single turn potentiometer with setpoint shown on label.
- Adjustable start delay to bypass inrush current.

Split-core Case

- Sensing window provides ample space for bus bar, single or multiple conductors.

DIN Rail** or Panel Mounted Case

- Simple snap onto DIN rail or attach with screws to a panel for secure mounting.

UL/cUL and CE Approved

- Accepted worldwide.

*For a description of failsafe operation, see the installation instructions.

**For information on the DIN rail accessories kit, see page 128.

Current Sensing Switch Connections

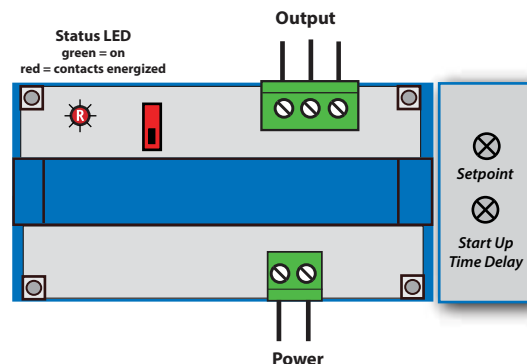

OEMs Test & Evaluation Units for OEMs
Free program expedites evaluation process. See page 3 for details.

Current Sensing Switch Dimensions

LS Case

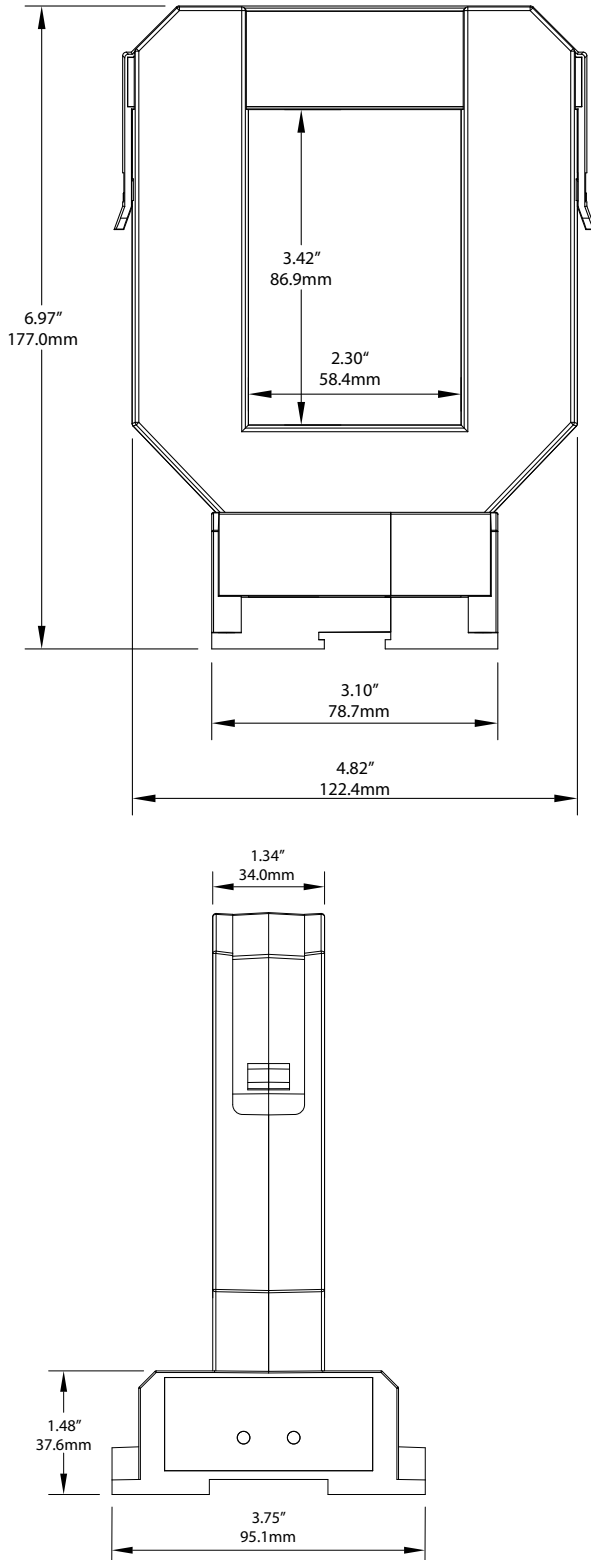

Note: Drawings are not to scale

Current Sensing Switch Specifications



Power Supply	• 120 VAC (108–132 V) • 24 VAC/DC (22–36 V)
Power Consumption	<4 VA
Input Range	• 8: 200–800 A • 10: 400–1000 A • 12: 600–1200 A • 16: 1000–1600 A
Output Description	Electromechanical SPDT relay
Output Rating	1 A @ 120 VAC, 2 A @ 30 VDC max.
Indicating Bi-color LED	Green: Power on, current within range Red: Power on, current over setpoint Off: Power off or current less than 20% of range
Output Operation	Selectable: Normal or failsafe*
Response Time	900 ms max.
Time Delay	0.5 to 16 sec. (adjustable)
Hysteresis	5%
Isolation Voltage	UL listed to 1270 VAC, tested to 5 kV
Frequency Range	10–100 Hz
Case	UL94 V-0 Flammability Rated
Environmental	-4 to 122°F (-20 to 50°C) 0–95% RH, non-condensing
Listings	UL/cUL, CE

*For a description of failsafe operation, see the installation instructions.

Current Sensing Switch Ordering Information

Sample Model Number: ASXP8-SDT-24U-LS

AC current sensing switch, 200–800 A range, single pole, SDT relay (Form C), 24 VAC/DC, split-core case, DIN rail mounting.



(1) Range

8	200–800 A
10	400–1000 A
12	600–1200 A
16	1000–1600 A

(2) Output Type

SDT	SPDT Relay (Form C)
-----	---------------------

(3) Power Supply

24U	24 VAC/DC
120	120 VAC

(4) Case Style

LS	Split-core, base terminals, DIN rail mounting
----	---

Current Sensing Switches



DS1 SERIES

DC Current Sensing Switches

The DS1 Series Current Sensing Switches are designed to trip a solid-state contact when there is DC current through the sensor window. The sensor can be used to interlock two operations for safety. When one load is energized, the contact will keep another from also energizing. The power supply voltage and the controlled circuit voltage can be derived from a single source or separate sources. The monitored circuit can be any DC voltage and any amount of current as long as the conductor will pass through the window. The monitored circuit is completely isolated from the control circuit. If there is 3/4 of one amp through the aperture, the output will change state.



Current Sensing Switch Applications

- As a safety interlock, it is a non-intrusive method to keep personnel safe.
- Alarm contact when a load is operating or when it is not energized.
- Detect PV system leakage by monitoring the earth bond conductor.
- Use the contact to turn on a lighting circuit when a load is energized.
- Instant indication of equipment status.

Current Sensing Switch Features

Compact, One-piece Design

- Fits in easily amongst motor starters and power supplies in crowded control cabinets.

Input Isolation

- Safer than shunt/relay combinations.

Unique Power Supply Connection

- Sensor power and switched load share a common point making installation easy.

Built-in Mounting Feet

- Simple, two-screw installation allows for secure mounting.

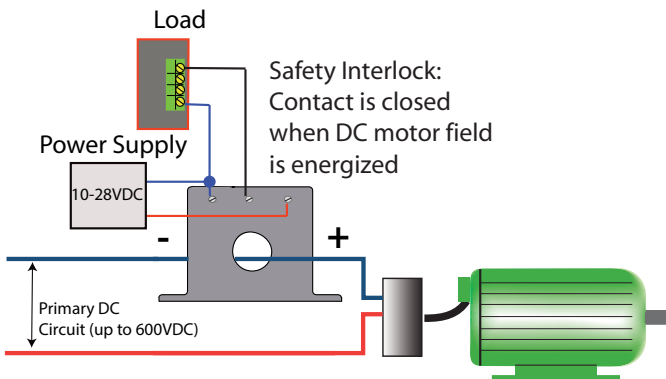

For additional Application Examples, go to www.nktechnologies.com/applications

OEMs Test & Evaluation Units for OEMs
Free program expedites evaluation process. See page 3 for details.

Current Sensing Switch Dimensions

FF Case

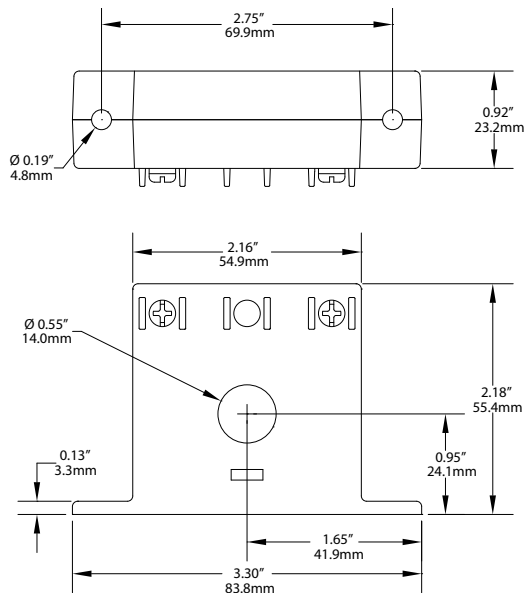

Current Sensing Switch Specifications

Power Supply	10–28 VDC
Power Consumption	<2 VA
Setpoint Range	0.75 A (factory set)
Output Description	Isolated solid-state relay
Off-state Leakage	<1 μ A
Response Time	600 ms max.
Time Delay	None, after 5 seconds when first powered up
Output Rating	1 A up to 30 VDC
Hysteresis	5%
Overload	500 A continuous, 1000 A @ 5 sec.
Isolation Voltage	Tested to 3 KV
Frequency Range	DC
Case	UL94 V-0 Flammability Rated
Environmental	-4 to 122°F (-20 to 50°C) 0–95% RH, non-condensing

Current Sensing Switches

Current Sensing Switch Connections

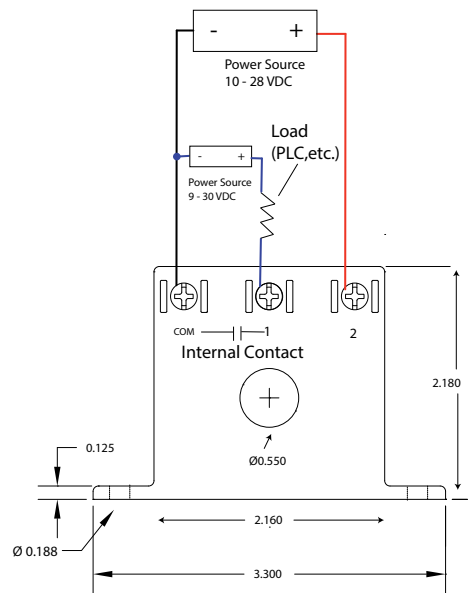

Notes:
Zinc plated screw terminals solid-core case.
Split core versions are not available.
12–22 AWG solid or stranded.

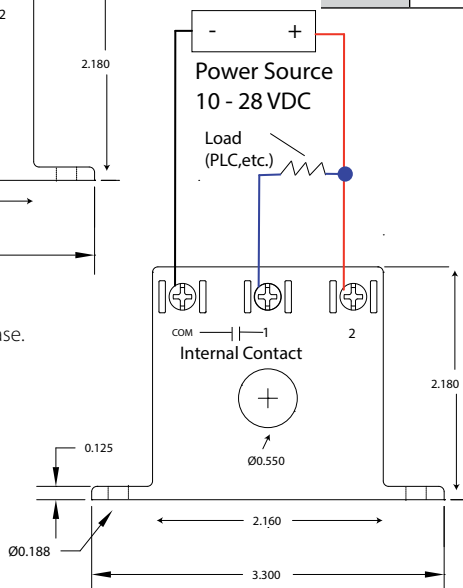

Current Sensing Switch Ordering Information

Sample Model Number: DS1-NODC-FF

Solid-core DC current sensing switch closes with 0.75 ADC, normally open, front terminal solid-core case. (DIN rail adapters are included)

DS ⁽¹⁾ **1** - ⁽²⁾ **N O D C** - ⁽³⁾ **FF**

(1) Range

1	0.75 ADC
---	----------

(2) Output Type

NODC	Normally Open (1 A @ 28 VDC)
------	------------------------------

(3) Case Style

FF	Solid-core, front terminals
----	-----------------------------



DS3 SERIES

Current Sensing Switches

DS3 Series Current Sensing Switches combine a Hall effect sensor, signal conditioner and a limit alarm into a single package. The DS3 Series offers three jumper-selected current input ranges and frequency response from DC to 400 Hz. Available in a solid-core case with choice of relay or a universal solid-state output.



Current Sensing Switch Applications

Welders and Platers

- Instant indication of equipment status.

Large Drive Motors

- Provides enhanced field loss protection.

Power Supplies

- Signals overcurrent before equipment fails.

Machine Operation

- Instant status of motors, lamps and other loads.

Telecom Sites

- Monitors battery output.

Current Sensing Switch Features

Compact, One-piece Design

- Fits in easily amongst motor starters and power supplies in crowded control panels.

Input Isolation

- Safer than shunt/relay combinations.

Output Installation

- Isolated output greatly simplifies wiring.

Tough

- Designed to handle a wide range of temperatures found in industrial environments.

Adaptive Hysteresis

- Hysteresis is 5% of setpoint, allowing closer control than fixed hysteresis switches.

Built-in Mounting Feet

- Simple, two-screw installation allows for secure mounting.

UL/cUL and CE Approved

- Accepted worldwide.

Failure Detection

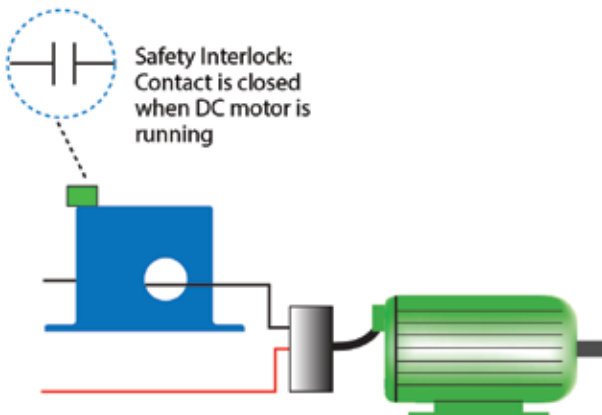

- For additional Application Examples, go to www.nktechnologies.com/applications

OEMs

Test & Evaluation Units for OEMs

Free program expedites evaluation process. See page 3 for details.

Current Sensing Switch Dimensions

Case

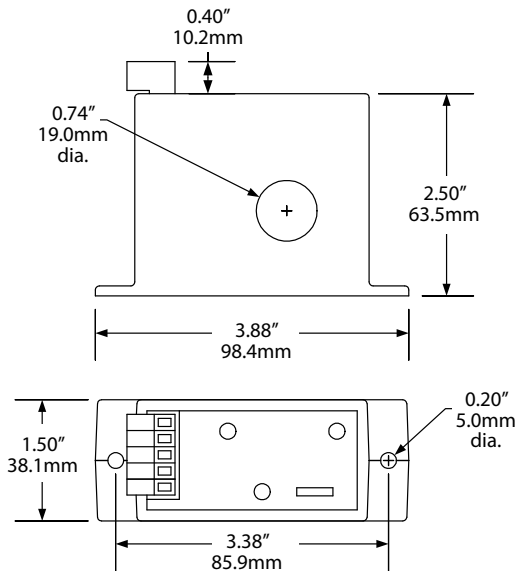

Current Sensing Switch Specifications



Power Supply	10–28 VDC
Power Consumption	<2 VA
Setpoint Range	2–20, 10–50 and 20–100 A DC adjustable (3–28, 14–71, 28–141 A AC)
Output Description	Isolated solid-state or relay contacts
Output Rating	• Solid-state: 0.15 A @ 240 VAC or VDC (N.O. only) • Relays: 5.0 A @ 240 VAC, 5.0 A @ 30 VDC (SPDT)
Off-state Leakage	<10 μ A (solid-state), none (relay)
Response Time	80 ms max.
Time Delay	None
Hysteresis	5%
Isolation Voltage	UL listed to 1270 VAC, tested to 3 kV
Frequency Range	DC to 400 Hz
Case	UL94 V-0 Flammability Rated
Environmental	-4 to 122°F (-20 to 50°C) 0–95% RH, non-condensing
Listings	UL/cUL, CE

Current Sensing Switches

Current Sensing Switch Connections

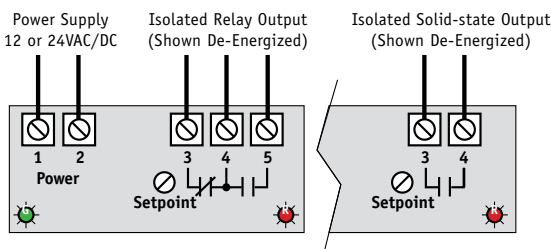

Notes:
Pressure plate screw terminals.
12–22 AWG solid or stranded.
Field-adjustable setpoint.

Current Sensing Switch Ordering Information

Sample Model Number: DS3-SDT-24U

DS current sensing switch with SPDT relay contacts and 24 VAC/DC power supply. (DIN rail adapters are included)

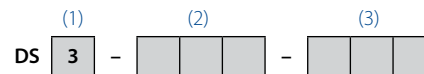

(1) Setpoint Range	3	2–20, 10–50 and 20–100 A, jumper-selectable
(2) Output Type	SDT	SPDT Relay (Form C)
	NOU	Solid-state N.O. AC/DC
(3) Power Supply	24U	+24 VAC/DC
	12U	+12 VAC/DC

DS3 Series Sample Output/Power Supply

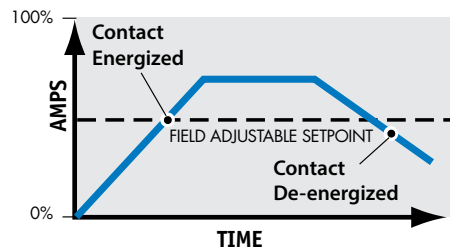

AC Current Transducers

Current Transducers are designed to provide an analog signal proportional to the AC current for monitoring, data logging and panel meter applications. NK Technologies' current transducers offer a choice of 0–5 VDC, 0–10 VDC or 4–20 mA average responding or True RMS outputs. Self-powered and split-core options make these a cost-effective choice as a PLC input in motor status applications or where VFDs are involved.

Features:

- Average responding or True RMS output
- Jumper-selectable ranges
- Solid-core, split-core and large aperture models

● AT SERIES AC Current Transducers.....	page 40
● ATR SERIES AC Current Transducers.....	page 42
● AT/ATR-FD SERIES AC Current Transducers.....	page 44
● AT/ATR-FL SERIES AC Current Transducers.....	page 46
● AT/ATR-MS SERIES AC Current Transducers.....	page 48
● AT/ATR-LS SERIES AC Current Transducers.....	page 50
● ATCR SERIES AC Current Transducers.....	page 52
● ATP SERIES AC Current Transducers.....	page 54
● ATPR VOLTAGE OUTPUT SERIES AC Current Transducers.....	page 56
● ATP/ATPR-FL SERIES AC Current Transducers.....	page 58
● ATH SERIES AC Current Transducer with Time Integration.....	page 60
● ATQ SERIES Frequency Output AC Current Transducers.....	page 62
● ATS SERIES WITH DIGITAL SETPOINT DISPLAY AC Current Transducer/Switch.....	page 64
● ATS SERIES WITH ROTARY SWITCH SETPOINT AC Current Transducer/Switch.....	page 66

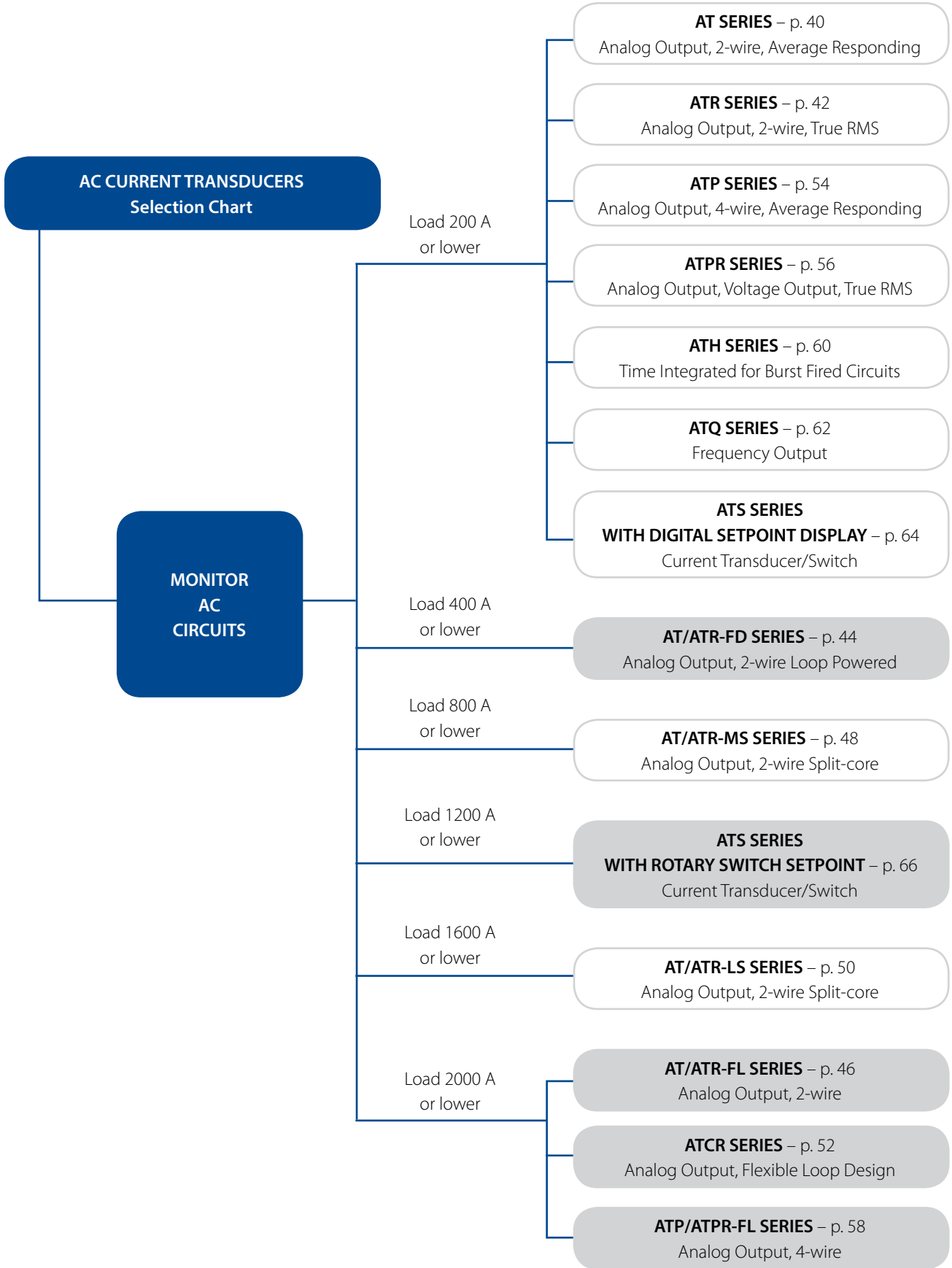

AT SERIES

AC Current Transducers

AT Series AC Current Transducers combine a current transformer and signal conditioner into a single package. These current transducers have jumper-selectable current input ranges and industry standard 4–20 mA, 0–5 VDC or 0–10 VDC outputs. The AT Series AC Current Transducers are designed for application on 'linear' or sinusoidal AC loads and are available in a split-core case or two types of solid-core cases.



AC Current Transducer Applications

Automation Systems

- Analog current reading for remote monitoring and software alarms.

Data Loggers

- Self-powered transducer helps conserve data logger batteries.

Panel Meters

- Simple connection displays power consumption.

Preventative Maintenance of a Critical Lighting System

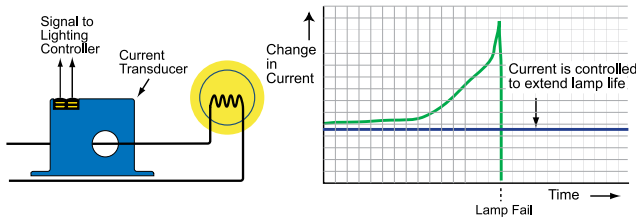

- For additional Application Examples, go to www.nktechnologies.com/applications

AT Series Power Supply

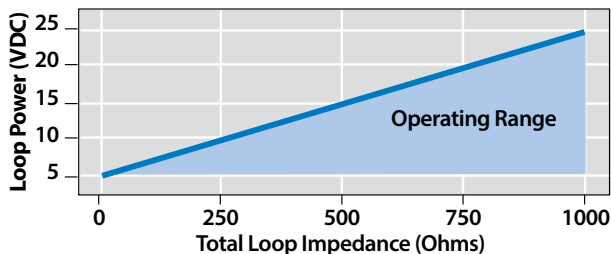

AC Current Transducer Features

Accurate

- Factory matched and calibrated single piece transducer is more accurate than traditional two-piece field installed solutions.

Average Responding

- "Average Responding" algorithm gives an RMS output on pure sine waves. Perfect for constant speed (linear) loads.

Jumper-selectable Ranges

- Reduces inventory.
- Eliminates zero and span pots.

Isolation

- Output is magnetically isolated from the input for safety.
- Eliminates insertion loss (voltage drop).

UL/cUL and CE Approved

- Accepted worldwide.

AC Current Transducer Connections

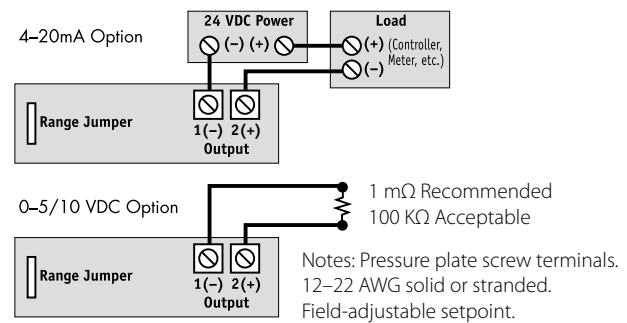

OEMs Test & Evaluation Units for OEMs
Free program expedites evaluation process. See page 3 for details.

AC Current Transducer Dimensions

FF Case

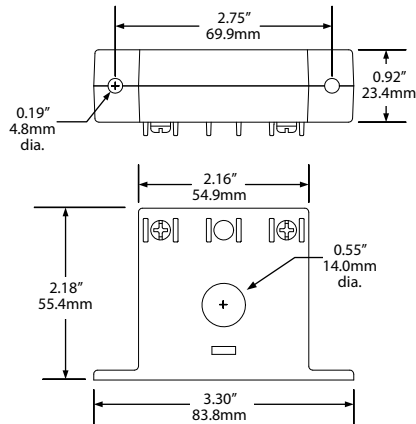

FT Case

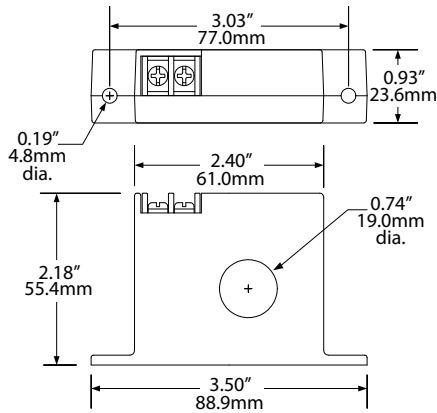

SP Case

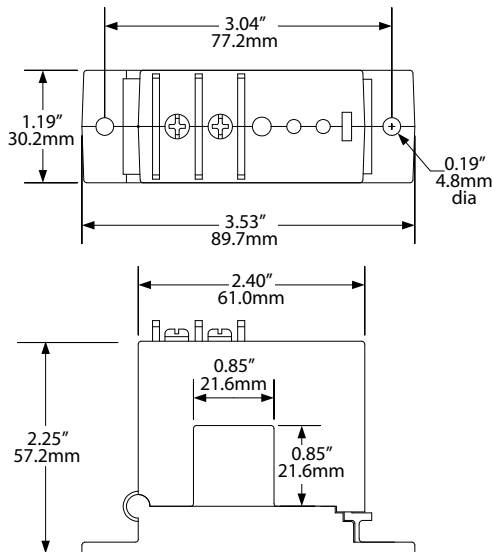

AC Current Transducer Specifications



	-005 MODEL	-010 MODEL	-420 MODEL
Power Supply	None, self-powered		5-40 VDC, loop-powered
Output Signal	0-5 VDC	0-10 VDC	4-20 mA
Output Limit	8.2 VDC	15 VDC	32 mA
Output Impedance	1 megohm min., 100 KΩ add 1.3% error		Contact factory for power requirements
Accuracy	1.0% FS		
Response Time (90% step change)	100 ms		300 ms
Frequency Range	50-60 Hz		20-100 Hz*
Isolation Voltage	UL listed to 1270 VAC, tested to 5 KV		
Input Range	0-200 A Field-selectable; custom ranges available, consult factory		
Case	UL94 V-0 Flammability Rated		
Environmental	-4 to 122°F (-20 to 50°C) 0-95% RH, non-condensing		
Listing	UL/cUL, CE		

*For sinusoidal waveforms only. Select ATR Transducers for distorted waveforms.

AC Current Transducers

AC Current Transducer Ordering Information

Sample Model Number: AT1-005-000-SP

AC current transducer, 10/20/50 A range, self-powered with a 0-5 VDC output in a split-core case. (DIN rail adapters are included)

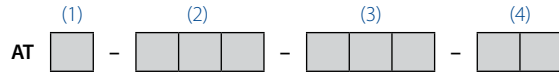

(1) Full Scale Range

0	2 & 5 A (4-20 mA only)
1	10, 20, 50 A
2	100, 150, 200 A

(3) Power Supply

24L	24 VDC loop-powered (4-20 mA output ONLY)
000	Self-powered (0-5/0-10 VDC output ONLY)

(2) Output Signal

420	4-20 mA
005	0-5 VDC
010	0-10 VDC

(4) Case Style

FF	Solid-core, front term.
FT	Solid-core, top term.
SP	Split-core



ATR SERIES

AC Current Transducers

ATR Series AC Current Transducers combine a current transformer and a True RMS signal conditioner into a single package. These current transducers provide True RMS output on distorted waveforms found on VFD or SCR outputs, and on linear loads in “noisy” power environments. The ATR Series AC Current Transducers are available in a solid- or split-core case.



AC Current Transducer Applications

VFD Controlled Loads

- Monitoring VFD output indicates how the motor and attached load are operating.

SCR Controlled Loads

- Accurate measurement of phase angle fired (time proportioned) SCRs.
- Current measurement gives faster response than temperature measurement.

Switching Power Supplies and Electronic Ballasts

- True RMS sensing is the most accurate way to measure power supply or ballast input power.

AC Current Transducer Features

True RMS Output

- True RMS technology is accurate on distorted waveforms like VFD or SCR outputs.

Jumper-selectable Ranges

- Reduces inventory.
- Eliminates zero and span pots.

Isolation

- Output is magnetically isolated from the input for safety.
- Eliminates insertion loss (voltage drop).

UL/cUL and CE Approved

- Accepted worldwide.

Monitoring a Motor Driven with a VFD

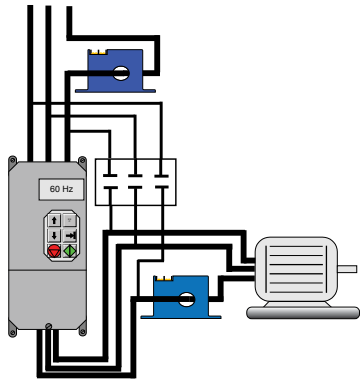

Use the ATR current transducer on the line or load side of the drive and the signal will be accurate in either position.

- For additional Application Examples, go to www.nktechnologies.com/applications

Selecting the right transducer:

The current waveforms of a typical linear load is a pure sine wave. In VFD and phase angle fired SCR applications, however, output waveforms are rough approximations of a sine wave. There are numerous spikes and dips in each cycle. ATR transducers use a mathematical algorithm called “True RMS” which integrates the actual waveforms over time. The output is the amperage component of the true power (heating value) of the AC current waveforms. True RMS is the only way to accurately measure distorted AC waveforms. **Select ATR transducers for nonlinear loads in “noisy” power environments.**

OEMs

Test & Evaluation Units for OEMs

Free program expedites evaluation process. See page 3 for details.

AC Current Transducer Dimensions

FT Case

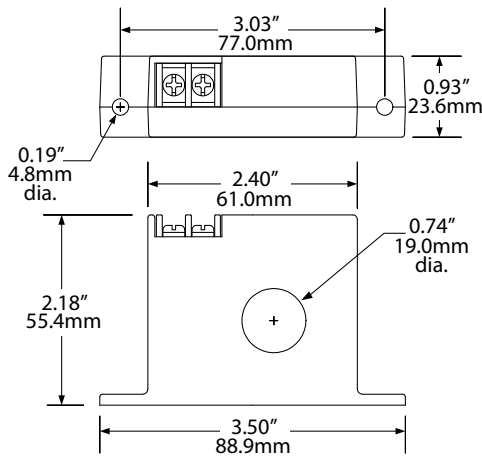

SP Case

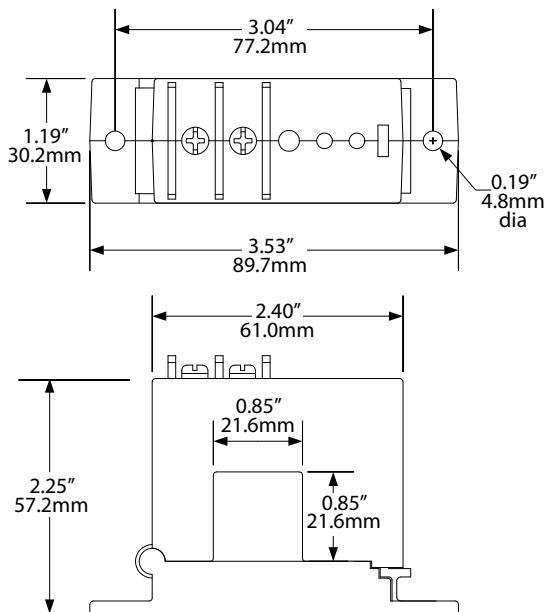

AC Current Transducer Connections

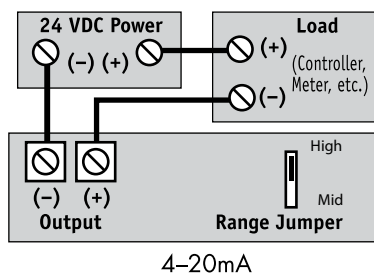

Notes:
 Deadfront captive screw terminals (-SP case).
 12-22 AWG solid or stranded.
 Observe polarity.

AC Current Transducer Specifications



Power Supply	24 VDC (12-40 VDC)
Output Signal	4-20 mA loop-powered, average or True RMS
Output Limit	23 mA
Output Impedance	<750 Ω @ 24 VDC
Accuracy	1.0% FS
Response Time	600 ms (to 90% step change)
Frequency Range	10-400 Hz
Isolation Voltage	UL listed to 1270 VAC, tested to 5 KV
Input Range	0-200 A (adjustable); consult factory for custom ranges
Case	UL94 V-0 Flammability Rated
Environmental	-4 to 122°F (-20 to 50°C) 0-95% RH, non-condensing
Listings	UL/cUL, CE

AC Current Transducers

AC Current Transducer Ordering Information

Sample Model Number: ATR1-420-24L-SP

True RMS AC current transducer, 10/20/50 A ranges, 4-20 mA output, 24 VDC loop-powered in a split-core case. (DIN rail adapters are included)



(1) Full Scale Range

0	2, 5 A
1	10, 20, 50 A
2	100, 150, 200 A

(2) Output Signal

420	4-20 mA
-----	---------

(3) Power Supply

24L	24 VDC loop-powered (4-20 mA output ONLY)
-----	---

(4) Case Style

FT	Solid-core, top terminals
SP	Split-core



AT/ATR-FD SERIES

AC Current Transducers

AT/ATR-FD Series AC Current Transducers provide a current sensor and analog output signal conditioning in a single package. The large, easy-to-install solid-core design allows for quick installation even in applications where there are multiple conductors per phase. Just thread the conductor through the extra large aperture and reconnect on the other side. The transducer output is powered from excitation voltage of around 24 VDC, using just two wires. The sensor mounts on a back panel or a DIN rail, and is designed to accommodate wire sizes for loads up to 400 A.



AC Current Transducer Applications

Monitor Large Machines

- Detect over or undercurrent conditions before they cause breakdowns or interlock one process with another.

Water Delivery and Treatment

- Detect open discharge lines.
- Sense clogged filters or blocked intake to pumps.
- Measure increased current to show failing bearings or pump impeller cavitation.

Generators

- Shed noncritical loads when demand reaches a set level.

Shredders

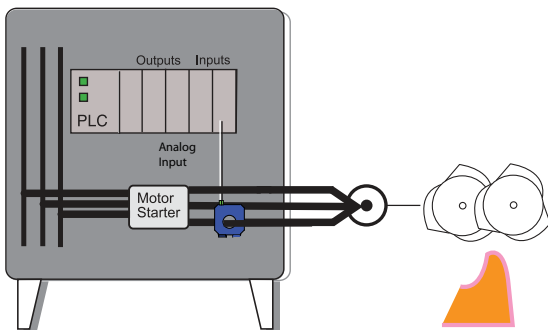

Monitor a shredding operation to measure current usage, enabling automatic shut down if the blades become jammed or overloaded.

- For additional Application Examples, go to www.nktechnologies.com/applications

AC Current Transducer Features

4–20 mA Analog Signal Proportional to AC Current

- Both average responding and True RMS models available.
- Compatible with most automation and control systems.

2-Wire Loop Powered

- Simple and reliable connection.

Factory Calibrated with Five Year Warranty

- Choice of three ranges : 0–200, 300 or 400 A.
- Designed for longest life and reliability.

Solid-core Case

- Sensing window provides ample space for a bus bar, a single conductor or multiple conductors.

DIN Rail or Panel Mount

- Simply snap onto DIN rail or attach with screws to a panel for secure mounting.

UL/cUL Approved, CE Approval Pending

- Accepted worldwide.

OEMs Test & Evaluation Units for OEMs
Free program expedites evaluation process. See page 3 for details.

AC Current Transducer Dimensions

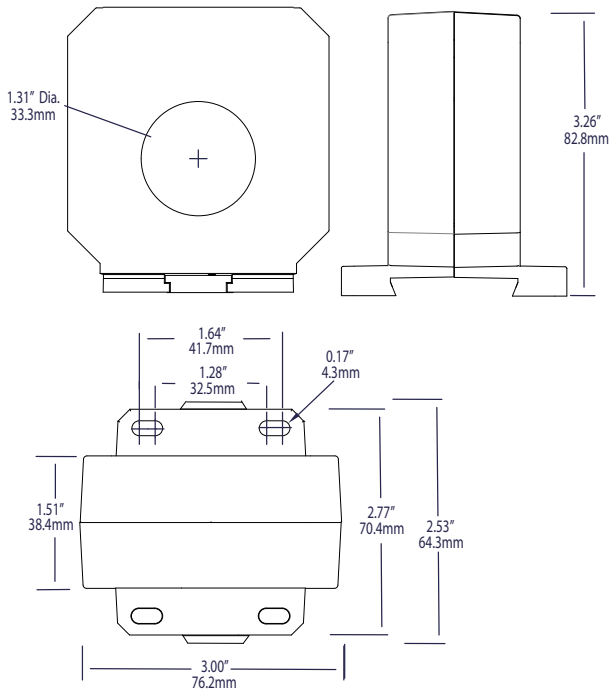

AC Current Transducer Connections

Single Transducer Installation

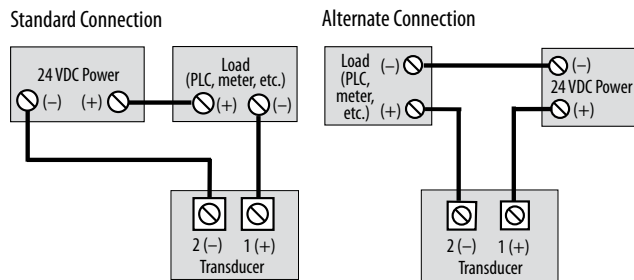

Loop Power Requirement

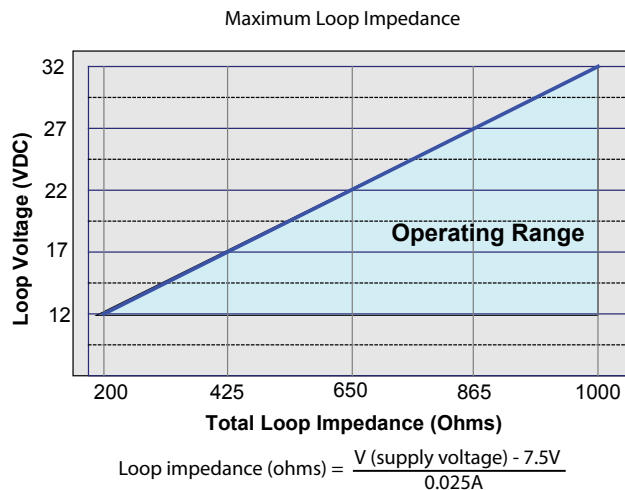

AC Current Transducer Specifications



Power Supply	Loop-powered
Power Consumption	<2 VA
Output Signal	4–20 mA loop-powered, average or True RMS (max. 28 mA)
Output Impedance	<660 Ω @ 24 VDC
Accuracy	1.0% FS
Response Time (90% step change)	• AT: 300 ms • ATR: 1.4 sec.
Range	• AT2: 0–200 A • AT3: 0–300 A • AT4: 0–400 A
Frequency Range	• AT: 40–400 Hz • ATR: 20–400 Hz
Isolation Voltage	UL listed to 1270 VAC, tested to 5 kV
Case	UL94 V-0 Flammability Rated
Environmental	-4 to 122°F (-20 to 50°C) 0–95% RH, non-condensing
Listings	UL/cUL, CE pending

AC Current Transducers

AC Current Transducer Ordering Information

Sample Model Number: ATR2-420-24L-FD
AC RMS current transducer, 0–200 A range, 4–20 mA output, 24 VDC loop-powered, medium solid-core case, DIN rail mounting.



(1) Output Type	Average Responding (Blank)
R	True RMS
(2) Range	2 0–200 A
3	0–300 A
4	0–400 A
(3) Output	420 4–20 mA
(4) Power Supply	24L 24 VDC loop-powered
(5) Case Style	FD Solid-core, top terminals, DIN rail or panel mounting



AT/ATR-FL SERIES

AC Current Transducers

AT/ATR-FL Series AC Current Transducers combine a current transformer and a signal conditioner into a single package for applications from 100 A to 2000 A. The AT version is Average Responding for use on linear (sinusoidal) loads. The ATR version is True RMS for use on distorted waveforms found in VFD or SCR outputs. The AT/ATR-FL Series AC Current Transducers are available in a solid-core case.

AC Current Transducer Applications

Large Pumps

- Detect dry run electronically.

Power Generation

- Measure the output of generators.

Electric Heating Elements

- Monitors heater loads.
- Faster response than temperature sensors.



AC Current Transducer Features

Large Aperture

- Accommodates large conductors or wire bundles.

Select the Right Output

- True RMS technology is accurate on distorted waveforms like those associated with VFD or SCR outputs.
- Average Responding for use with linear, sinusoidal waveforms.

Jumper-selectable Ranges

- Reduces inventory.
- Eliminates zero and span pots.

Isolation

- Output is magnetically isolated from the input for safety.
- Eliminates insertion loss (voltage drop).

UL/cUL and CE Approved

- Accepted worldwide.

Selecting the right transducer:

The current waveforms of a typical linear load is a pure sine wave. AT transducers measure the peaks of these sine waves, then calculate the average amperage. This works well on constant speed linear loads in “clean” power environments. Select AT transducers for strictly linear loads on “clean” power.

VFD and SCR output waveforms are rough approximations of a sine wave. There are numerous spikes and dips in a mathematical algorithm called “True RMS,” which integrates the actual waveforms over time. The output is the amperage component of the true power (heating value) of the AC current waveforms. True RMS is the only way to accurately measure distorted AC waveforms. **Select ATR transducers for nonlinear loads on “noisy power.”**

Motor Load Monitoring

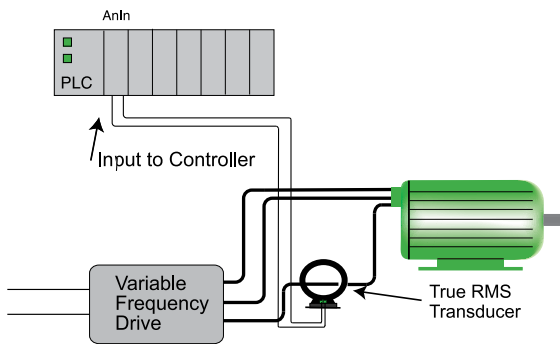

- For additional Application Examples, go to www.nktechnologies.com/applications

OEMs Test & Evaluation Units for OEMs
Free program expedites evaluation process. See page 3 for details.

AC Current Transducer Dimensions

FL Case

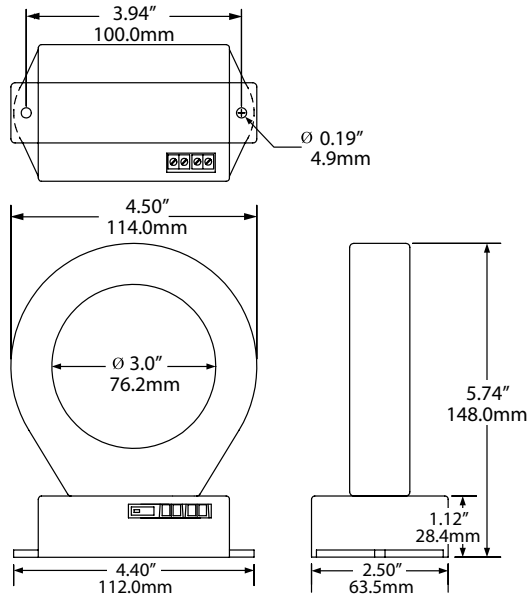

AC Current Transducer Connections

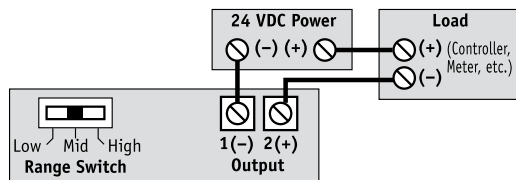

Notes:
 Deadfront captive screw terminals.
 12–22 AWG solid or stranded.
 Observe polarity.

AC Current Transducer Specifications



Power Supply	24 VDC
Output Signal	4–20 mA loop-powered, average or True RMS
Output Limit	23 mA
Output Impedance	<750 Ω @ 24 VDC
Accuracy	1.0% FS, True RMS
Measurement	True RMS or Average Responding (see ordering information)
Response Time	600 ms (to 90% step change)
Frequency Range	• ATR: 10–400 Hz • AT: 50–60 Hz, sinusoidal
Isolation Voltage	UL listed to 600 VAC, tested to 5 KV
Input Range	• AT/ATR2: 100, 133, 200 A • AT/ATR3: 375, 500, 750 A • AT/ATR4: 1000, 1333, 2000 A
Case	UL94 V-0 Flammability Rated
Environmental	-4 to 122°F (-20 to 50°C) 0–95% RH, non-condensing
Listings	UL/cUL, CE

AC Current Transducers

AC Current Transducer Ordering Information

Sample Model Number: ATR3-420-24L-FL
 True RMS AC current transducer, 24 VDC, powered with a 4–20 mA output, 375/500/750 A ranges in a solid-core case.



(1) Measurement	R True RMS Average Responding (blank)
(2) Full Scale Range	2 100, 133, 200 A 3 375, 500, 750 A 4 1000, 1333, 2000 A
(3) Output Signal	420 4–20 mA
(4) Power Supply	24L 24 VDC loop-powered
(5) Case Style	FL Solid-core



AT/ATR-MS SERIES

AC Current Transducers

AT/ATR-MS Series Current Transducers combine a current sensing element and signal conditioner into a single package. The large, easy-to-install split-core design allows for installation over existing conductors without the need to disconnect the load, even in applications where there are multiple conductors per phase. Whether installing over existing conductors or in a new control system, installation is very simple and quick. Just remove the top portion of the sensing ring, place the conductors inside, and snap the top back in place. The transducer uses two wires to connect to the power supply or the load (a programmable logic controller, a panel meter, or a data acquisition system).



AC Current Transducer Applications

Monitor Large Machines

- Measure the current use to detect over or undercurrent conditions before they cause break downs.

Water Delivery and Treatment

- Detect open discharge lines.
- Locate clogged filters or blocked intake to pumps.

Grinding and Shredding

- An analog output will allow the control system designer to allow brief periods of drive overload when the processed product varies in density. If the blades hit something foreign (e.g. steel when the machine is designed to reduce paper), then the control will alarm or shut down the process.

AC Current Transducer Features

Industry Standard Output

- 4–20 mA signal proportional to the AC current.
- Compatible with most automation systems.

Loop-powered

- Use the “live zero” output to verify proper connections, where the sensor output is 4 mA with no current through the sensing ring.

Factory Calibrated

- Eliminates zero and span potentiometer adjustment.

Split-core Case

- Sensing window provides ample space for bus bar, single or multiple conductors.

DIN Rail Mounted Case*

- Simply snaps onto DIN rail for secure mounting.

UL/cUL Approved, CE Approval Pending

- Accepted worldwide.

*For information on the DIN rail accessories kit, see page 128.

Shredder Monitoring

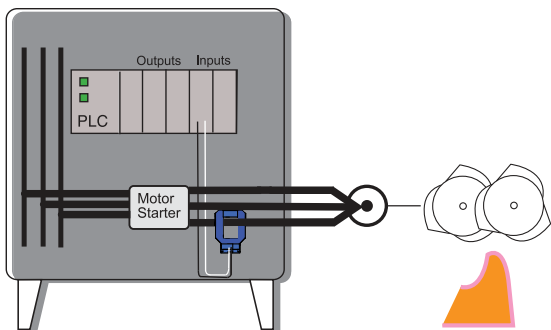

- For additional Application Examples, go to www.nktechnologies.com/applications

OEMs Test & Evaluation Units for OEMs
Free program expedites evaluation process. See page 3 for details.

AC Current Transducer Dimensions

MS Case

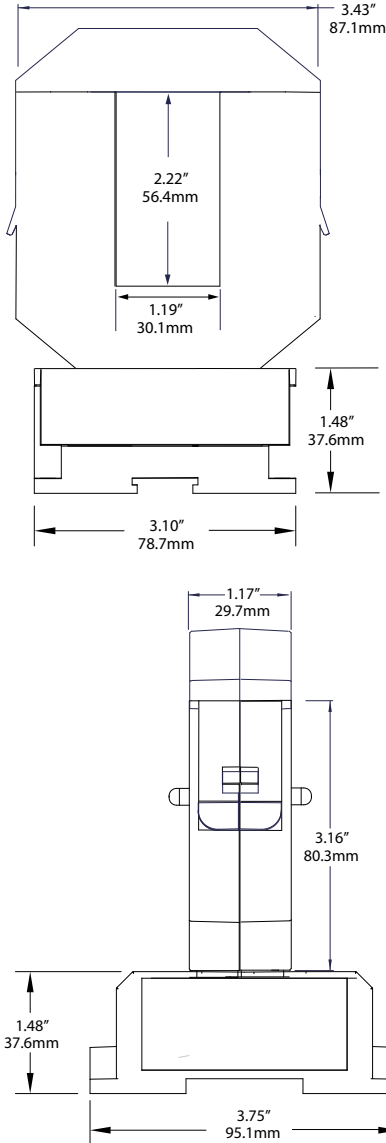

Note: Drawings are not to scale

AC Current Transducer Connections

Single Transducer Installation

Standard Connection

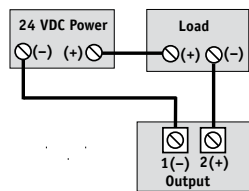

Alternate Connection

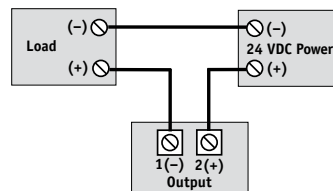

AC Current Transducer Specifications



Power Supply	24 VDC nominal (12–32 VDC)
Output Signal	4–20 mA loop-powered, average or True RMS
Output Limit	23 mA
Output Impedance	<750 Ω @ 24 VDC
Accuracy	1.0% from 10–100% of range
Response Time	600 ms (90% step change)
Range	2: 0–200 A 4: 0–400 A 6: 0–600 A 8: 0–800 A
Frequency Range	• AT: 50/60 Hz (average responding) • ATR: 20–400 Hz (True RMS responding)
Isolation Voltage	UL tested to 2000 VAC isolation, monitored conductor to output terminals
Case	UL94 V-0 Flammability Rated
Environmental	-4 to 122°F (-20 to 50°C) 0–95% RH, non-condensing
Listings	UL/cUL, CE pending

AC Current Transducers

AC Current Transducer Ordering Information

Sample Model Number: ATR6-420-24L-MS
AC current transducer, 0–600 A range, True RMS output 4–20 mA, loop-powered, medium split-core case, DIN rail mounting.

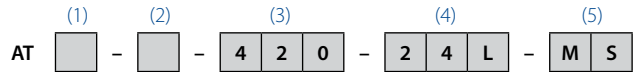

(1) Measurement

	Average responding output signal (blank)
R	True RMS responding output for distorted current

(2) Range

2	0–200 A
4	0–400 A
6	0–600 A
8	0–800 A

(3) Output Type

420	4–20 mA
-----	---------

(4) Power Supply

24L	24 VDC Loop-power (12–32 VDC)
-----	-------------------------------

(5) Case Style

MS	Split-core, base terminals, DIN rail mounting
----	---



AT/ATR-LS SERIES

AC Current Transducers

AT/ATR-LS Series Current Transducers combine a current transformer and signal conditioner into a single package. The large, easy-to-install, split-core design allows for installation over existing conductors without the need to disconnect the load (a programmable logic controller, a panel meter, or a data acquisition system), even in applications where there are multiple conductors per phase. For new installations, the installation is just as easy. Just remove the top portion of the sensing ring, place the conductors inside, and snap the top back in place. The transducer uses two wires to connect to the power supply and the load (a programmable logic controller, a panel meter or a data acquisition system).

AC Current Transducer Applications

Monitor Large Machines

- Measure the current use to detect over or undercurrent conditions before they cause break downs.

Water Delivery and Treatment

- Detect open discharge lines.
- See clogged filters or blocked intake to pumps.

Generators

- Keep the power system running by monitoring the output.

Grinder/Shredder Application

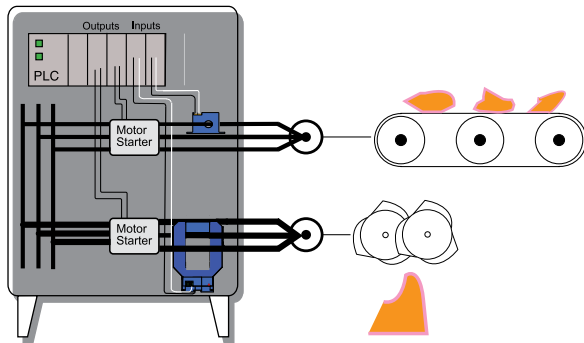

For additional Application Examples, go to www.nktechnologies.com/applications



AC Current Transducer Features

Industry Standard Output

- 4–20 mA signal proportional to the AC current.
- Compatible with most automation systems.

Loop-powered

- Use the “live zero” output to verify proper connections (sensor output with no current flowing confirms the system is ready to go).

Factory Calibrated

- Eliminates zero and span potentiometer adjustment.

Split-core Case

- Sensing window provides ample space for bus bar, single or multiple conductors.

DIN Rail Mounted Case*

- Simple snap onto DIN rail for secure mounting.

UL/cUL Approved

- Accepted worldwide.

*For information on the DIN rail accessories kit, see page 128.

AC Current Transducer Connections

Standard Connection

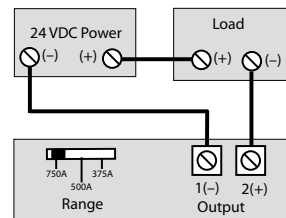

Alternate Connection

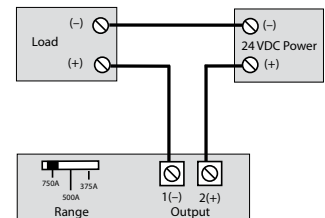

OEMs Test & Evaluation Units for OEMs
Free program expedites evaluation process. See page 3 for details.

AC Current Transducer Dimensions

LS Case

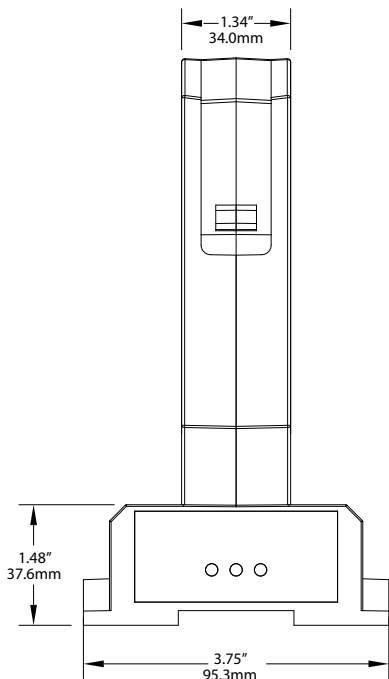
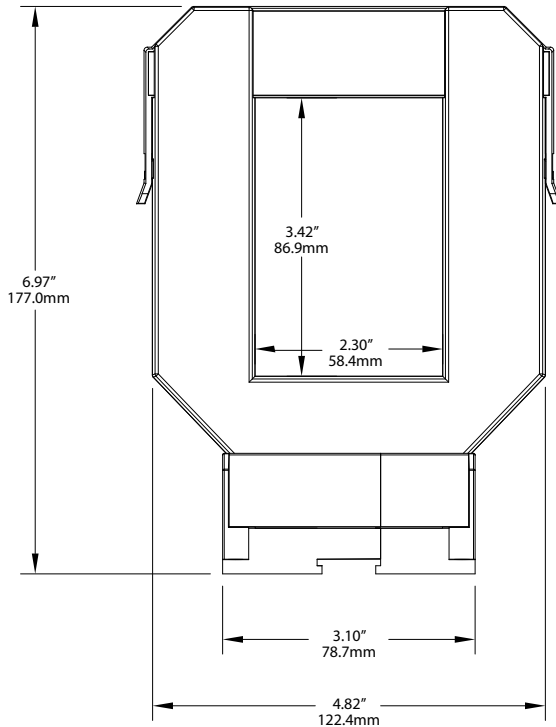

Note: Drawings are not to scale

AC Current Transducer Specifications



Power Supply	24 VDC nominal (12–32 VDC)
Output Signal	4–20 mA loop-powered, average or True RMS
Output Limit	23 mA
Output Impedance	<750 Ω @ 24 VDC
Accuracy	1.0% FS
Response Time	600 ms (90% step change)
Range	8: 0–800 A 10: 0–1000 A 12: 0–1200 A 16: 0–1600 A
Frequency Range	• AT: 50/60 Hz (average responding) • ATR: 20–400 Hz (True RMS responding)
Isolation Voltage	UL tested to 2000 VAC isolation, monitored conductor to output terminals
Case	UL94 V-0 Flammability Rated
Environmental	-4 to 122°F (-20 to 50°C) 0–95% RH, non-condensing
Listings	UL/cUL

AC Current Transducers

AC Current Transducer Ordering Information

Sample Model Number: ATR10-420-24L-LS
AC current transducer, 0–1000 A range, True RMS output 4–20 mA, loop-powered, large split-core case, DIN rail mounting.

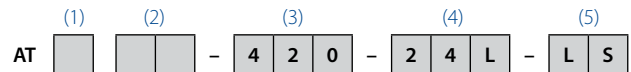

(1) Measurement

	Average responding (blank)
R	True RMS responding output for distorted current

(2) Range

8	0–800 A
10	0–1000 A
12	0–1200 A
16	0–1600 A

(3) Output Type

420	4–20 mA
-----	---------

(4) Power Supply

24L	24 VDC loop-powered
-----	---------------------

(5) Case Style

LS	Split-core, base terminals, DIN rail mounting
----	---



ATCR SERIES

AC Current Transducers

ATCR Series AC Current Transducers combine a sensing coil and a True RMS signal conditioner as a matched, factory-calibrated set. The ATCR Series AC Current Transducers are designed to produce an analog 4–20 mA signal proportional to AC current up to 2000 A. The coil opens to pass over the installed conductors. When connected to a controller or data logger, the sensor output is directly proportional to the primary current.



AC Current Transducer Applications

Monitor Large Machines

- Monitoring resistive or inductive load to detect current.
- Industry standard 4–20 mA output for connection to PLC or data loggers.

Flexible Coil Surrounds Conductors Without Disturbing Wiring

- Install over bus bars, or single or multiple conductors easily.
- Fast response to changes in operating conditions.

Two-Wire Loop-powered Output

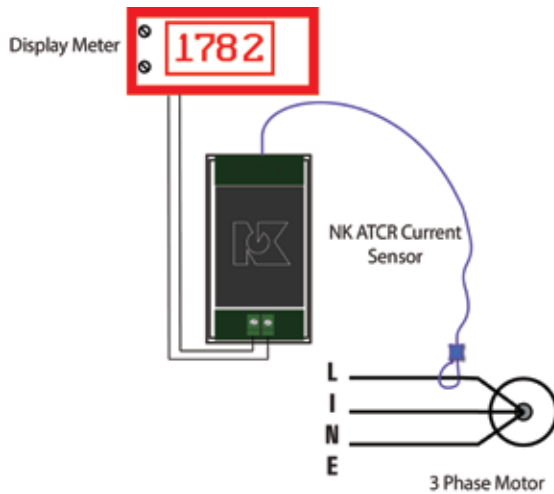

- For additional Application Examples, go to www.nktechnologies.com/applications

AC Current Transducer Features

True RMS Output

- True RMS technology is accurate on distorted waveforms like VFD or phase angle-fired SC outputs.

Single Range

- No chance of field range selection errors.
- Eliminates zero and span pots.

Isolation

- Output is magnetically isolated from the input for safety.
- Eliminates insertion loss (voltage drop).

Compact DIN Rail Mounted Case*

- Space saving 35 mm wide enclosure mounts quickly.

UL/cUL and CE Approved

- Accepted worldwide.

*For information on the DIN rail accessories kit, see page 128.

AC current monitoring of large loads:

Loads drawing large amounts of power are connected to the supply using large wire or a bus bar. Disconnecting the conductors and threading them through a solid sensing ring or current transformer is difficult and time consuming. With this new design, the sensing is accomplished using a coil without a magnetically permeable core. This allows the installer to pass the coil around the conductors after they are connected without the need to disconnect. The coil is attached to a signal conditioning circuit, and the output signal is powered from the 24 VDC nominal loop voltage. Simple, easy to install, the ATCR Current Sensor can monitor sinusoidal or distorted current waveforms at frequencies to 400 Hz, and is designed for industrial uses.

OEMs Test & Evaluation Units for OEMs
Free program expedites evaluation process. See page 3 for details.

AC Current Transducer Dimensions

Base

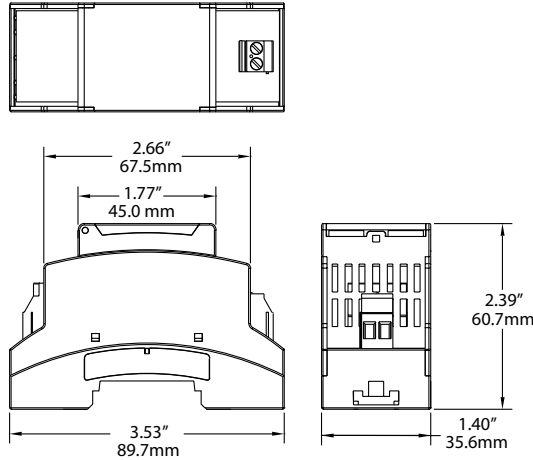

Coil

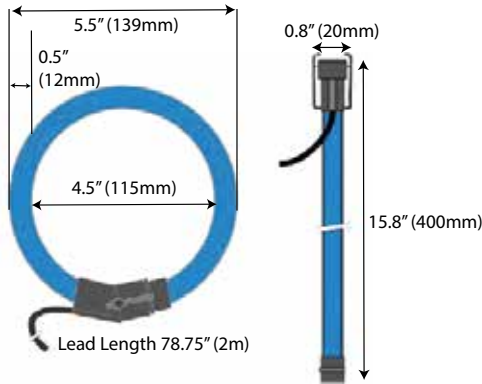

AC Current Transducer Connections

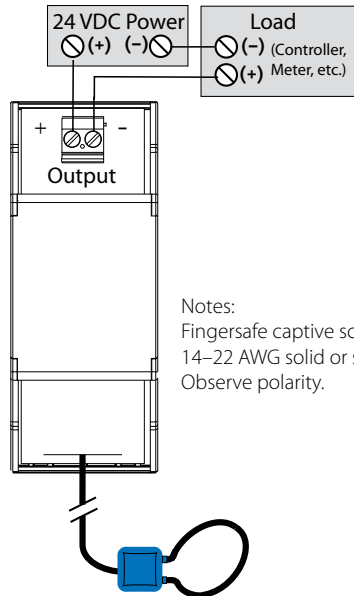

Notes:
 Fingersafe captive screw terminals.
 14–22 AWG solid or stranded.
 Observe polarity.

AC Current Transducer Specifications



Power Supply	24 VDC nominal (12–36 VDC)
Output Signal	4–20 mA loop-powered, True RMS
Output Limit	23 mA
Output Impedance	<750 Ω @ 24 VDC
Accuracy	1.0% from 10–100% of range
Response Time	600 ms (90% step change)
Frequency Range	40–400 Hz
Isolation Voltage	UL listed to 1270 VAC, tested to 5 kV
Input Range	Single range, custom ranges available; consult factory
Case	UL94 V-0 Flammability Rated
Environmental	-4 to 122°F (-20 to 50°C) 0–95% RH, non-condensing
Listings	UL/cUL, CE

AC Current Transducers

AC Current Transducer Ordering Information

Sample Model Number: ATCR1-420-24L-D
 True RMS AC current transducer, 500 A range, 4–20 mA output, 24 VDC loop-powered, coil sensor connected to DIN rail mounting case.

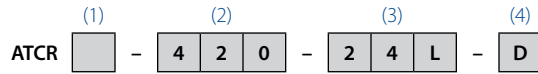

(1) Full Scale Range

1	500 A
2	1000 A
3	1500 A
4	2000 A

(2) Output Signal

420	4–20 mA
-----	---------

(3) Power Supply

24L	24 VDC loop-powered (4–20 mA output ONLY)
-----	---

(4) Case Style

D	Coil connected to DIN rail mounting case
---	--



ATP SERIES

AC Current Transducers

ATP Series AC Current Transducers sense currents from 0–200 A and provide a proportional analog VDC or mA output. Externally powered by 120 VAC/DC or 24 VAC/DC, the ATP Series AC Current Transducers eliminate the need for costly power supplies or voltage rectifiers inside the control panel. Designed for motor control applications with standard sinusoidal waveforms, these transducers feature user-selectable input ranges, a choice of outputs and split-core or solid-core cases.



AC Current Transducer Applications

Commercial and Industrial Motor Control Centers

- 120 VAC/DC power supply option allows for powering off of readily available supplies; ideal for pumping, water/wastewater, boiler and other industrial applications.
- Eliminates the need for 24 VDC power supply or AC rectifiers within the control panel; saves space, material and labor associated with power supplies.

Heater Failure Detection

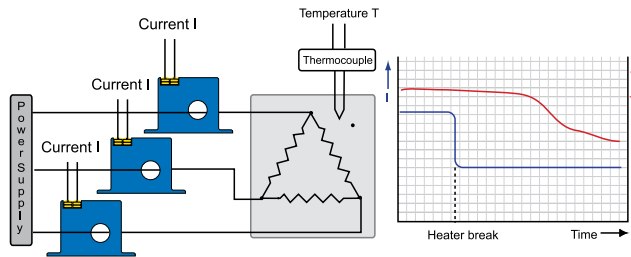

For additional Application Examples, go to www.nktechnologies.com/applications

AC Current Transducer Features

Fast, Accurate RMS Measurement

- Unique ‘average responding’ algorithm provides RMS output on pure sine wave and constant speed loads, offering improved accuracy over two-piece solutions.

Jumper-selectable Input Ranges

- Each unit has multiple input range capability and can be used for a variety of applications, reducing the need for separate models.

Isolation Output

- Output is magnetically isolated from the input for enhanced safety and elimination of insertion losses.

Designed for UL/cUL and CE Approval

- Accepted worldwide.

AC Current Transducer Connections

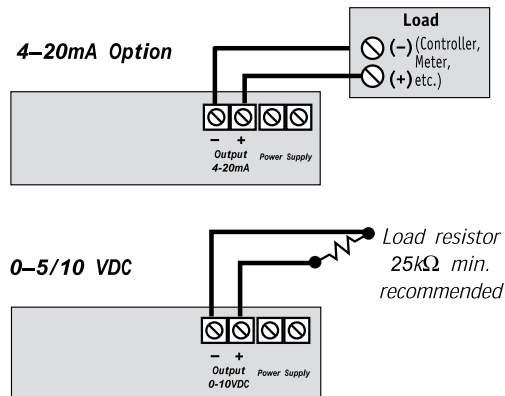

Notes:
Terminals are deadfront captive screw terminals.
Use 12–22 AWG solid or stranded.

OEMs Test & Evaluation Units for OEMs
Free program expedites evaluation process. See page 3 for details.

AC Current Transducer Dimensions

FF Case

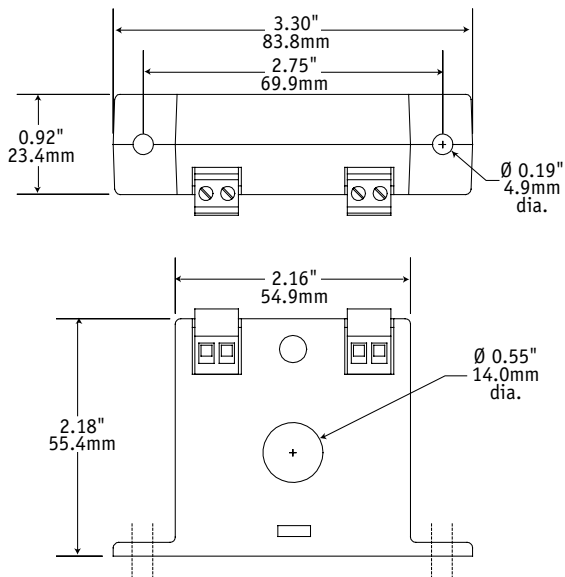

SP Case

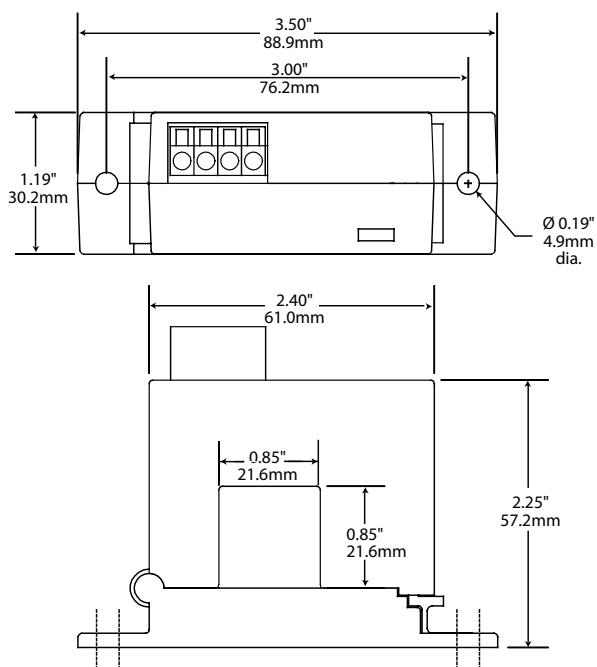

AC Current Transducer Specifications

Power Supply	<ul style="list-style-type: none"> • 120 VAC/DC (108–132 V) • 24 VAC/DC (22–26 V)
Power Consumption	<2 VA
Output Signal	<ul style="list-style-type: none"> • -005 Model: 0–5 VDC • -010 Model: 0–10 VDC • -420 Model: 4–20 mA
Output Limit	<ul style="list-style-type: none"> • -005 Model: 112% (5.6 V) • -010 Model: 112% (11.2 V) • -420 Model: 112% (22.4 mA)
Output Impedance	25 K Ω min.: VDC models 500 Ω max.: 4–20 mA models
Accuracy	1.0% FS
Response Time	100 ms (10–90% step change)
Frequency Range	40–100 Hz standard
Isolation Voltage	UL listed to 1270 VAC, tested to 5 KV
Input Range	0–200 A jumper-selectable
Case	UL94 V-0 Flammability Rated
Environmental	-4 to 122°F (-20 to 50°C) 0–95% RH, non-condensing
Listings	Designed for UL/cUL and CE approval

AC Current Transducers

AC Current Transducer Ordering Information

Sample Model Number: ATP1-420-120-SP

Powered AC current transducer, jumper-selectable 0–10/20/50 A range, 4–20 mA output, 120 VAC/DC power supply, split-core case. (DIN rail adapters are included)



(1) Full Scale Range

0	2, 5 A
1	10, 20, 50 A
2	100, 150, 200 A

(2) Output Signal

005	0–5 VDC
010	0–10 VDC
420	4–20 mA

(3) Power Supply

120	120 VAC/DC
24U	24 VAC/DC with isolated output

(4) Case Style

FF	Solid-core
SP	Split-core



ATPR VOLTAGE OUTPUT SERIES

AC Current Transducers

ATPR AC Current Transducers combine a current transformer with a True RMS signal conditioner in a single package. These current transducers produce a 0–5 or 0–10 VDC True RMS output on distorted waveforms found in the output of variable frequency drives, phase angle fired heating controls and on linear loads in “noisy” power environments. The ATPR Series AC Current Transducers are available in split-core case only.



AC Current Transducer Applications

VFD Controlled Loads

- Monitor the output of variable frequency driven loads, even when the unit is in bypass mode.

SCR Controlled Loads

- Accurate measurement of phase angle fired heating controls.
- Current measurement produces a quicker response to element failure than temperature controls.

Switching Power Supplies and Electronic Ballasts

- True RMS sensing is the most accurate way to measure power supply and ballast input power.

Monitoring a Variable Frequency Drive

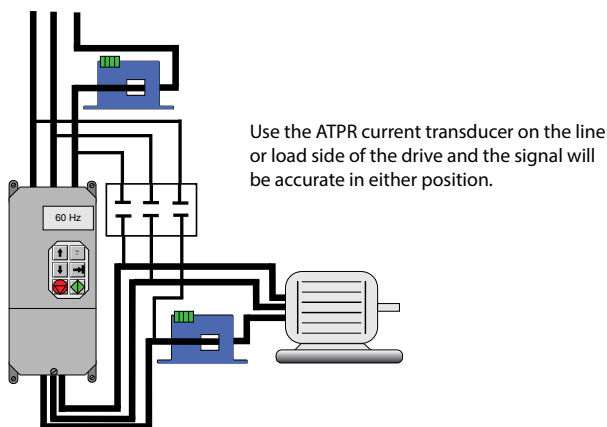

- For additional Application Examples, go to www.nktechnologies.com/applications

AC Current Transducer Features

True RMS Sensing

- Sensor output is proportional to the current flowing in the circuit, even with high distortion or harmonic loads.
- Compatible with most automation systems.

External Powered

- Provides the highest degree of accuracy and response.

Range-selectable

- One sensor covers a wide variety of loads.
- Field-selectable ranges keep spare part inventory at a minimum and allow for changes in load conditions.

Split-core Case

- Simple installation, release the latch and snap over the conductor.

DC Voltage Output

- Perfect for data acquisition systems, panel meters or controllers with only voltage inputs available.

Built-in Mounting Feet

- Simple, two-screw panel mounting or attach with DIN rail brackets (included).*

Designed for UL/cUL Approval, CE Approved

- Accepted worldwide.

*For information on the DIN rail accessories kit, see page 128.

OEMs

Test & Evaluation Units for OEMs

Free program expedites evaluation process. See page 3 for details.



AC Current Transducer Dimensions

SP Case

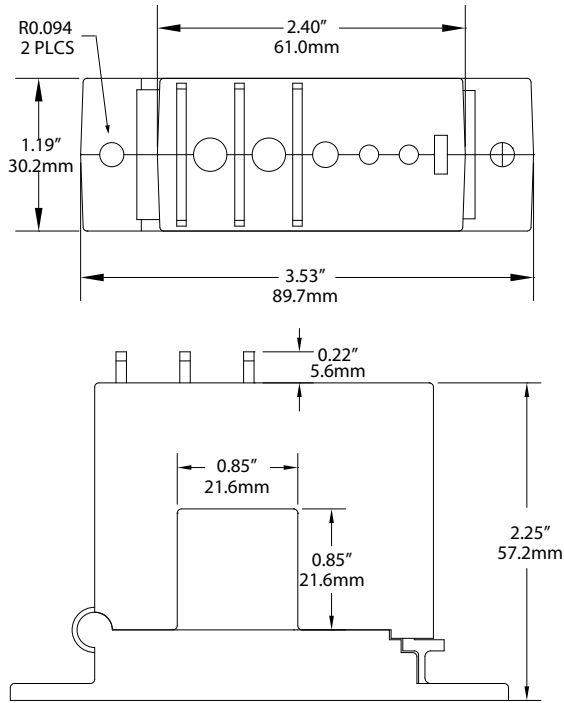

AC Current Transducer Connections

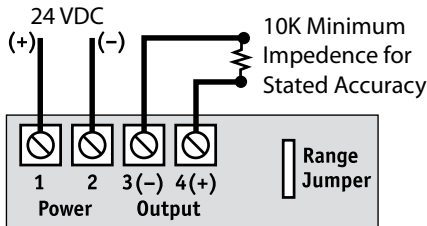

AC Current Transducer Specifications

Power Supply	24 VDC (20–28 VDC)
Power Consumption	<2 VA
Output Signal	• 0–5 VDC, proportional to True RMS current • 0–10 VDC, proportional to True RMS current
Output Impedance	10 KΩ min.
Response Time	600 ms
Frequency Range	10–400 Hz
Isolation Voltage	UL listed to 1270 VAC, tested to 5 KV
Case	UL94 V-0 Flammability Rated
Environmental	-4 to 122°F (-20 to 50°C) 0–95% RH, non-condensing
Listings	Designed for UL/cUL and CE approval

AC Current Transducer Ordering Information

Sample Model Number: ATPR1-010-24D-SP

True RMS AC current transducer, 10/20/50 A FS input ranges, 0–10 VDC output, 24 VDC power supply, split-core case. (DIN rail adapters are included)



(1) Full Scale Range

0	2, 5 A
1	10, 20, 50 A
2	100, 150, 200 A

(2) Output Type

005	0–5 VDC, True RMS
010	0–10 VDC, True RMS

(3) Power Supply

24D	24 VDC nominal (20–28 VDC)
-----	----------------------------

(4) Case Style

SP	Split-core
----	------------



ATP/ATPR-FL SERIES

AC Current Transducers

ATP/ATPR-FL Series High-AC-Current Transducers are large-format solid-core transducers designed for high current applications from 200 A to 2000 A. Powered by 120 VAC or 24 VAC/DC, the ATP/ATPR-FL Series takes advantage of available power supplies and eliminates the need for costly control power transformers. Options include average responding and True RMS versions, 0–5/10 VDC or 4–20 mA analog outputs and switch-selectable input ranges.



AC Current Transducer Applications

Commercial and Industrial MCC's

- Fits conveniently in motor control centers, senses current on industrial motors and provides analog inputs back to PLC or controller.

VFD or SCR Controlled Loads, Electronic Ballasts

- Helpful in monitoring VFD-controlled motors to provide operational status. Provides accurate measurement of ballast input power and phase angle fired SCRs.

Large Pumping Applications

- Ideal for proof-of-flow in water/wastewater, boiler and other industrial pumping applications 150 HP and over. 120 VAC/DC or 24 VAC/DC supply options allow for powering off of readily available supply, eliminating need for CPTs.

Power Distribution Centers (PDCs)

- Monitors current output on commercial generation equipment and serves as a current input for use in power consumption calculations.

AC Current Transducer Features

Large Aperture

- Accommodates large conductors or wire bundles.

Select the Right Output

- True RMS technology is accurate on distorted waveforms like those associated with VFD or SCR outputs.
- Average Responding for use with linear, sinusoidal waveforms.

Jumper-selectable Ranges

- Reduces inventory.
- Eliminates zero and span pots.

Isolation

- Output is magnetically isolated from the input for safety.
- Eliminates insertion loss (voltage drop).

Designed for UL/cUL Approval, CE Approved

- Accepted worldwide.

Centrifugal Pump Monitoring

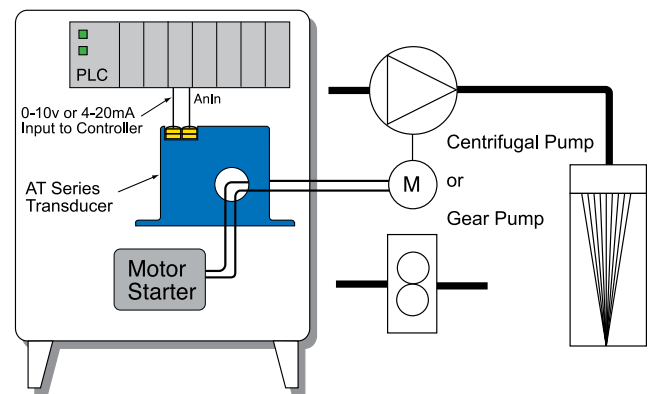

OEMs Test & Evaluation Units for OEMs
Free program expedites evaluation process. See page 3 for details.

For additional Application Examples, go to www.nktechnologies.com/applications



AC Current Transducer Dimensions

FL Case

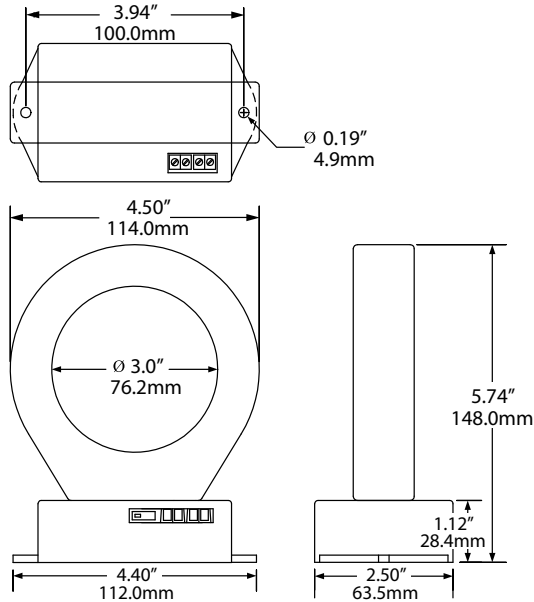

AC Current Transducer Connections

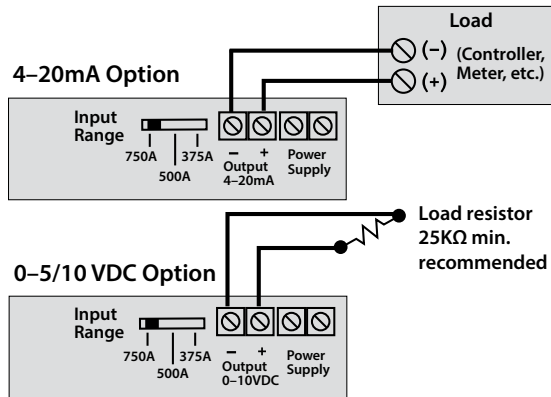

Notes:
Terminals are deadfront captive screw terminals.
Use 12–22 AWG solid or stranded.

AC Current Transducer Specifications

Power Supply	• 120 VAC/DC (108–132 V) • 24 VAC/DC (22–26 V)
Power Consumption	<2 VA
Output Signal	• -005 Model: 0–5 VDC • -010 Model: 0–10 VDC • -420 Model: 4–20 mA
Output Limit	• -005 Model: 112% (5.6 V) • -010 Model: 112% (11.2 V) • -420 Model: 112% (22.4 mA)
Output Impedance	25 K Ω min.: VDC models 500 Ω max.: 4–20 mA models
Accuracy	1.0% FS
Response Time	• ATP: 100 ms (10–90% step change) • ATPR: 600 ms (10–90% step change)
Frequency Range	• ATP: 40–100 Hz, sinusoidal • ATPR: 10–400 Hz
Isolation Voltage	UL listed to 600 VAC, tested to 5 KV
Input Range (switch-selectable)	• ATP3/ATPR3: 0–375 A/500 A/750 A • ATP4/ATPR4: 0–1000 A/1333 A/2000 A
Case	UL94 V-0 Flammability Rated
Environmental	-4 to 122°F (-20 to 50°C) 0–95% RH, non-condensing
Listings	Designed for UL/cUL and CE approval

AC Current Transducers

AC Current Transducer Ordering Information

Sample Model Number: ATPR-3-420-120-FL
True RMS AC current transducer, 120 VAC/DC, powered with a 4–20 mA output, 375/500/750 A ranges in a solid-core case.



(1) Measurement	
R	True RMS
	Average Responding (blank)
(2) Full Scale Range	
3	375, 500, 750 A
4	1000, 1333, 2000 A
(3) Output Signal	
005	0–5 VDC
010	0–10 VDC
420	4–20 mA
(4) Power Supply	
24U	24 VAC/DC
120	120 VAC/DC
(5) Case Style	
FL	Solid-core



ATH SERIES

AC Current Transducer with Time Integration

ATH Series (patented) AC Current Transducers are the latest innovation from NK Technologies. Monitoring the current or power controlled by silicon-controlled rectifiers (SCRs) can be a challenge, especially the current used by heaters. When used to monitor zero-crossing (burst) fired SCRs, the ATH will provide an output signal directly proportional to the RMS amperage. Zero-crossing fired controls allow current to flow to the circuit for as short of a time period as one cycle, and off for several cycles. Most current sensors will not work well when there is no current present. This capability is important in case a heating element fails but the process continues operating, which could result in scrapped material.

AC Current Transducer Applications

Electrical Heaters

- Faster response than temperature sensors.
- Simplest method to monitor pulsed waveforms.

Burst-Fired Heating Controls

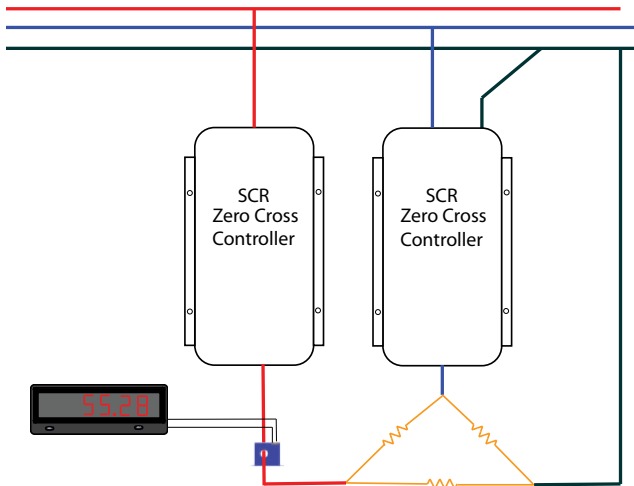

For additional Application Examples, go to www.nktechnologies.com/applications

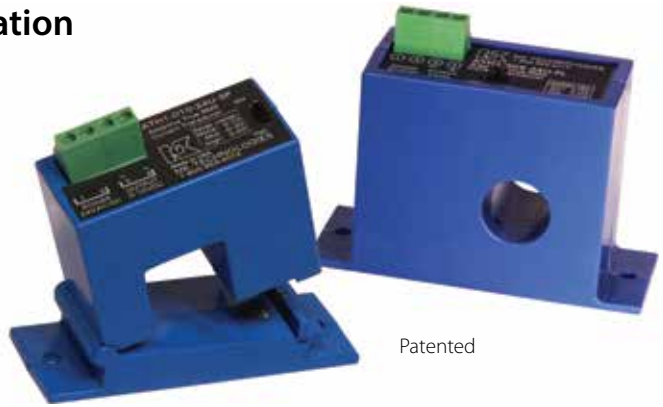

AC Current Transducer Features

Industry Standard Outputs

- 4–20 mA, 0–5 or 0–10 VDC.
- Compatible with most automation systems.

External Powered

- Split-core models available powered with 24 VAC or DC.
- Solid-core models powered with 24 VAC or DC or 120 VAC.

Factory Calibrated

- No need for zero and span adjustment potentiometers.

RMS Output

- Accurate measurement of sinusoidal or pulsed current wave shapes.

Built-in Mounting Feet

- Simple, two-screw panel mounting or attach with DIN rail brackets (included).*

UL/cUL and CE Approved

- Accepted worldwide.

*For information on the DIN rail accessories kit, see page 128.

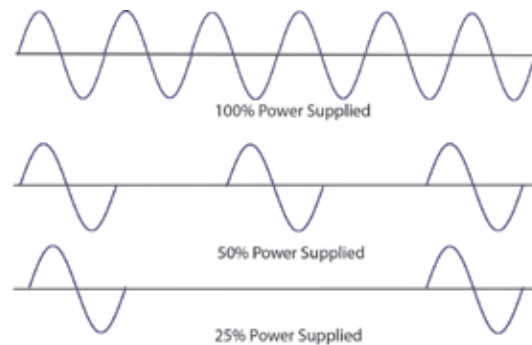

ATH AC current transducers will produce a signal proportional to the current used even when the controller is supplying power in one cycle increments. This is quite common as the “burst-fired” zero crossing switching method produces less harmonic distortion than phase-angle fired controls.

OEMs Test & Evaluation Units for OEMs
Free program expedites evaluation process. See page 3 for details.

AC Current Transducer Dimensions

SP Case

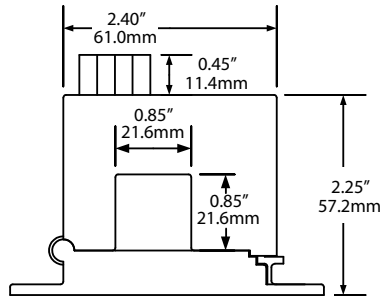
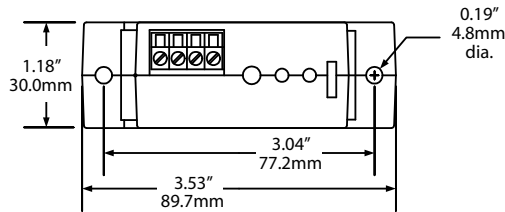

FL Case

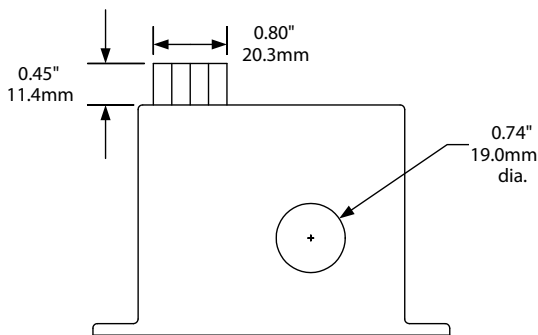
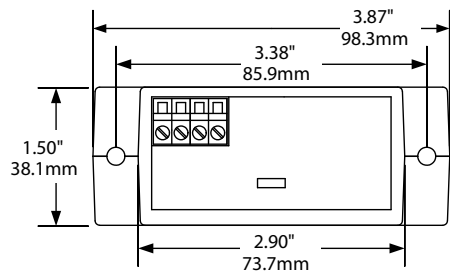

AC Current Transducer Specifications



Power Supply	• 120 VAC (108–132 V) solid-core only • 24 VAC/DC (22–26 V) solid or split-core
Output Signal	• 4–20 mA • 0–5 VDC • 0–10 VDC
Output Impedance	• 0–5 or 0–10 VDC: 10 KΩ min. • 4–20 mA: 500 Ω max.
Response Time	600 ms max., 250 ms at 100% power
Isolation Voltage	UL listed to 1270 VAC, tested to 5 kV
Case	UL94 V-0 Flammability Rated
Environmental	-4 to 122°F (-20 to 50°C) 0–95% RH, non-condensing
Listings	UL/cUL, CE

AC Current Transducers

AC Current Transducer Ordering Information

Sample Model Number: ATH1-420-24U-SP

AC current transducer, time proportioned, 4-20 mA output, 24 VAC or DC power supply, split-core case. (DIN rail adapters are included)



(1) Range

0	2 and 5 A
1	10, 20 and 50 A
2	100, 150 and 200 A

(2) Output Type

420	4–20 mA
005	0–5 VDC
010	0–10 VDC

(3) Power Supply

24U	24 VAC or DC
120	120 VAC

(4) Case Style

SP	Split-core
FL	Solid-core

AC Current Transducer Connections

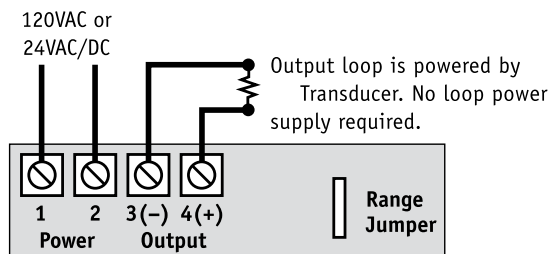

ATQ SERIES

Frequency Output AC Current Transducers

ATQ Series AC Current Transducers have a patented frequency output design used as an input to high-speed counter or frequency PLC modules, panel meters or programmable relays. Use where no analog inputs are available. Eight ranges, from 0–2 to 0–200 A, across three models provide the best available resolution. The ATQ Series AC Current Transducers are designed with a split-core case for easy installation.



AC Current Transducer Applications

Motion and Motor Control

- Pump, grinder, and fan motor status monitoring.
- Belt jam sensing in conveyor applications.
- Motor control in deburring/brush operations.
- Detect strain, acts as an electronic shear pin.

Current Measurement

- Measure current use in machine tools, polishing, and cutting operations where a small PLC has sufficient capacity to accept the sensor inputs measuring speed, time of use and electrical demands of the equipment.

AC Current Transducer Features

True RMS Output

- True RMS technology is accurate on distorted waveforms like VFD or SCR outputs.

Jumper-selectable Ranges

- Reduces inventory.
- Eliminates zero and span pots.

Isolation

- Output is magnetically isolated from the input for safety.
- Eliminates insertion loss (voltage drop).

Easy Installation

- Split-core case means the monitored conductor does not need to be disconnected to install the sensor.

Frequency Output Control

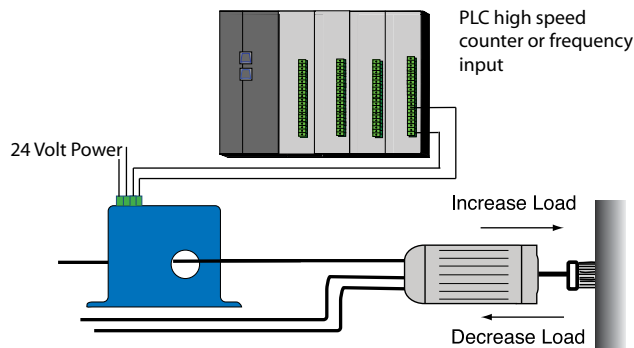

For additional Application Examples, go to www.nktechnologies.com/applications

OEMs Test & Evaluation Units for OEMs
Free program expedites evaluation process. See page 3 for details.

AC Current Transducer Dimensions

SP Case

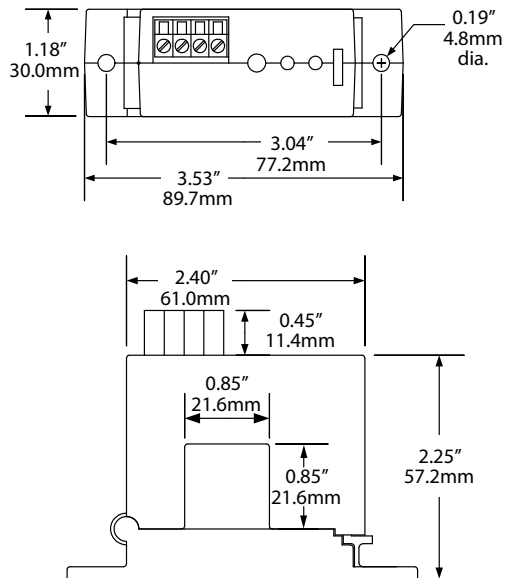

AC Current Transducer Specifications

Power Supply	24 VAC/DC (19–26 V)
Power Consumption	<1 VA
Output Signal	• 5 KHz at full range current • 10 KHz at full range current
Response Time	100 ms (to 90% step change)
Frequency Range	6–100 Hz
Input Frequency	10–400 Hz
Pulse Width	• 5 K: 90–100 ms • 10 K: 45–50 ms On: 40 ms Off: Variable
Isolation Voltage	UL listed to 1270 VAC, tested to 5 KV
Case	UL94 V-0 Flammability Rated
Environmental	-4 to 122°F (-20 to 50°C) 0–95% RH, non-condensing

AC Current Transducers

AC Current Transducer Connections

Sinking Input Connection

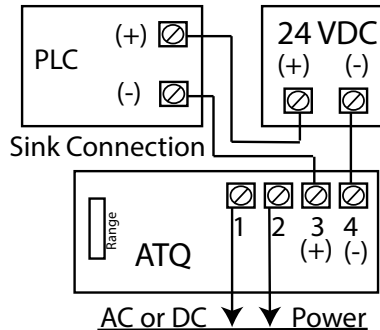

Sourcing Input Connection

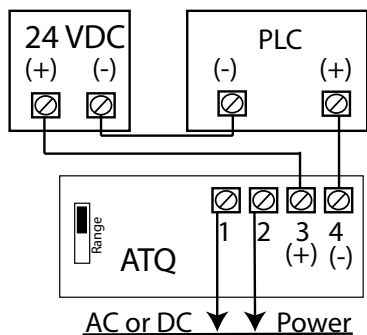

AC Current Transducer Ordering Information

Sample Model Number: ATQ1-05K-24U-SP

AC current transducer, 5K frequency at 10, 20 or 50 A, split-core case. (DIN rail adapters are included)



(1) Range	
0	2 and 5 A
1	10, 20, 50 A
2	100, 150, 200 A
(2) Frequency Output	
05K	5K Hz
10K	10K Hz
(3) Power Supply	
24U	24 VAC/DC power (external)
(4) Case Style	
SP	Split-core



ATS SERIES

AC Current Transducer/Switch with Digital Setpoint Display

ATS Series AC Current Sensors combine a current operated switch and transducer into a single package. The FL model features a digital display that gives visual indication of the setpoint for greater accuracy. The sensor provides a solid-state contact which will change state when the current exceeds an adjustable level or falls below the normal running current. This means reduced installation time, plus the option to have local control of a starter coil while at the same time sending the analog signal back to a controller housed in a separate cabinet.



Applications

Electronic Proof of Operation

- Current operated switches eliminate the need for multiple pipe or duct penetrations and are more reliable than electromechanical pressure or flow switches.

Conveyors

- Detects jams and overloads.
- Interlocks multiple conveyor sections.

Pump Control

- Provides signal to measure current and shuts down the pump if the current rises over the setpoint.

Cooling Towers

- Analog monitors time of use and contact opens if a filter clogs.

Pump Jam & Suction Loss Protection

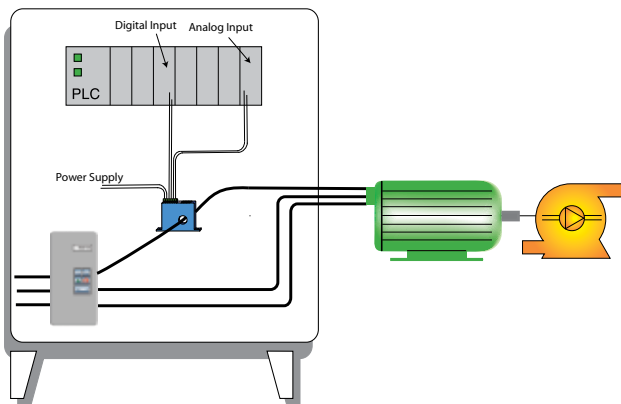

Features

Solid-state Output

- N.O. or N.C. solid-state switch for control circuits up to 240 VAC.
- Compatible with most automation systems.

External Powered

- Allows for higher accuracy.

Easily Adjustable and Precise Setpoint

- Speeds startup.

Analog Output

- Measure the current used at all times.

LED Display

- Provides quick visual indication of where the contact changes. Display flashes on and off when current has exceeded the setpoint.
- Easiest and most accurate setpoint adjustment available.

Built-in Mounting Feet

- Simple, two-screw panel mounting or attach with DIN rail brackets (included).*

UL/cUL Listed, Designed for CE Approval

- Accepted worldwide.

*For information on the DIN rail accessories kit, see page 128.

- For additional Application Examples, go to www.nktechnologies.com/applications

OEMs Test & Evaluation Units for OEMs
Free program expedites evaluation process. See page 3 for details.

AC Current Transducer Dimensions

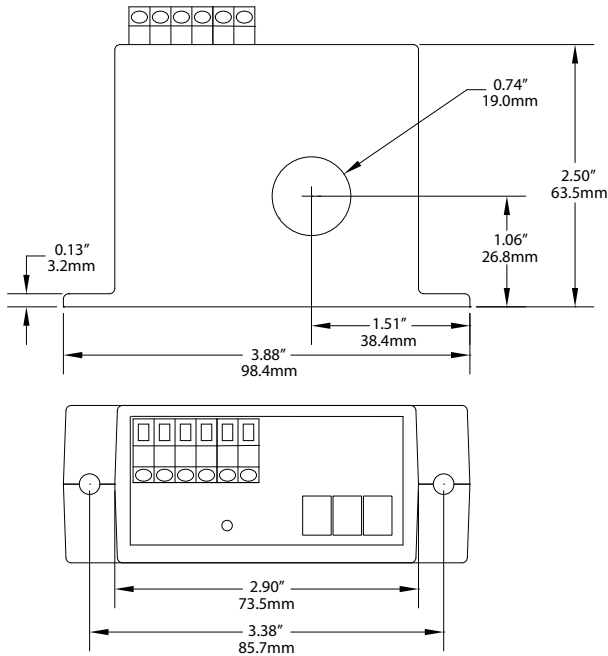

AC Current Transducer Connections

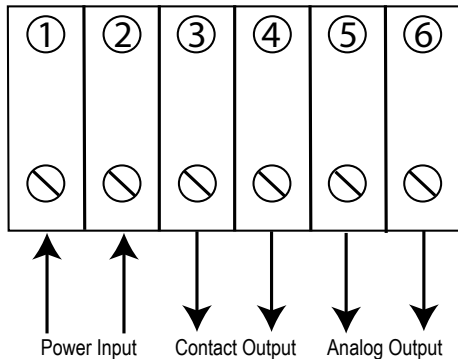

Display shows the trip point, and flashes when AC current exceeds that value. A trip point of 15 A is displayed as 015.

AC Current Transducer Specifications



Power Supply	24 VDC (18–28 V)
Power Consumption	40–70 mA
Input Range	<ul style="list-style-type: none"> • ATS1: 0–50 A • ATS2: 0–200 A
Output Signal	<ul style="list-style-type: none"> • 4–20 mA 500 Ω max. • 0–5 or 0–10 VDC: 5 KΩ max.
Output Limit	5/10 VDC; 20 mA
Output Impedance	<ul style="list-style-type: none"> • 4–20 mA 500 Ω max. • 0–5 or 0–10 VDC: 5 KΩ max.
Accuracy	+/-1.0% FS
Analog Response Time	250ms to 90% step change
Switch Response Time	<ul style="list-style-type: none"> • <500 ms for 5% over setpoint • <200 ms for 50% over setpoint • <150 ms for 100% over setpoint
Hysteresis	5%
Frequency Range	40–400 Hz
Setpoint Range	<ul style="list-style-type: none"> • ATS1: 1–50 A (adjustable) • ATS2: 4–200 A (adjustable)
Output	Isolated solid-state relay
Output Rating	1.0 A @ 240 VAC
Isolation Voltage	UL listed to 1270 VAC, tested to 5 KV
Case	UL94 V-0 Flammability Rated
Environmental	-4 to 122°F (-20 to 50°C) 0–95% RH, non-condensing
Listings	UL/cUL Listed, CE pending

AC Current Transducers

AC Current Transducer Ordering Information

Sample Model Number: ATS1-420-NOAC-24U-FL

Adjustable AC current operated switch/transducer, normally open, solid-core case. (DIN rail adapters are included)

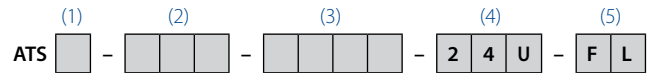

(1) Range

1	0–50 Analog, 1–50 switch adjustment
2	0–200 Analog, 4–200 switch adjustment

(2) Analog Signal Type

420	4–20 mA (powered by sensor)
005	0–5 VDC
010	0–10 VDC

(3) Output Contact

NOAC	Normally Open, closes on current rise, AC control only
NCAC	Normally Closed, opens on current rise, AC control only

(4) Power Supply

24U	24 VAC or DC
-----	--------------

(5) Case Style

FL	Solid-core
----	------------



ATS SERIES

AC Current Transducer/Switch with Rotary Switch Setpoint

The ATS Series AC Current Sensors combine a current operated switch and transducer into a single package for use in AC current applications up to 1200 A. The large sensing window provides complete isolation between the primary circuit and the controls. The DIN rail mounting makes installation a breeze, and provides a very secure mounting that is resistant to conductor movement.

Rotary Switch Setpoint Selection (patented set point adjustment)



AC Current Transducer Applications

Large AC Motor Loads

- Produces an analog signal at all times to detect increases or decreases in current.
- Provides limit alarm contacts for over or undercurrent conditions.
- Extra large aperture allows for single or multiple conductor passage.

Main Service Entrance

- Allows a viewer to see the amount of current used at any time when connected to a standard panel meter.

Generators

- Measure the AC current produced or consumed.
- Detect mechanical problems before failure occurs.

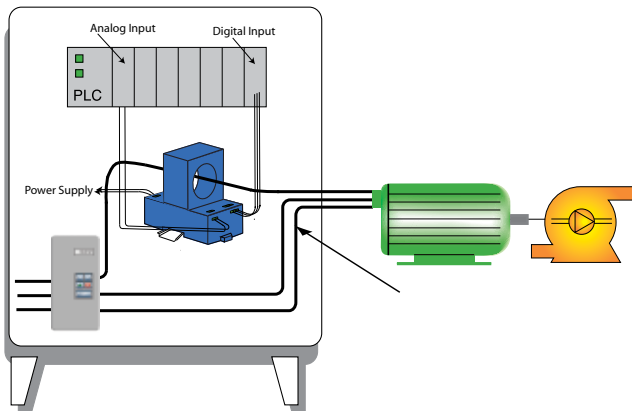

For additional Application Examples, go to www.nktechnologies.com/applications

AC Current Transducer Features

Easily Established Relay Actuation Point

- Patented rotary switch setpoint selection (patent pending).
- Trip point indicated on the labeling.

Isolation

- Output is magnetically isolated from the input for safety.
- Eliminates insertion losses, no added burden.

Analog Signal Available At All Times

- 4–20 mA signal proportional to 0–1200 AC A.
- Reduces components by combining transducer and limit alarm (current switch).
- Analog signal powered from the sensor; no loop powered required.

DIN Rail Mounted Case*

- Integral DIN rail mount with spring loaded mounting clips.
- Makes installation a snap.

Failsafe Relay Action

- Single Pole Double Throw Relay changes state with power to the sensor.
- LED indication if power is removed from the sensor or primary current exceeds the adjustable trip point.
- Field-adjustable time delay from 0.5 to 12 seconds.

UL/cUL Approved

- Accepted worldwide.

*For information on the DIN rail accessories kit, see page 128.

OEMs Test & Evaluation Units for OEMs
Free program expedites evaluation process. See page 3 for details.

AC Current Transducer Dimensions

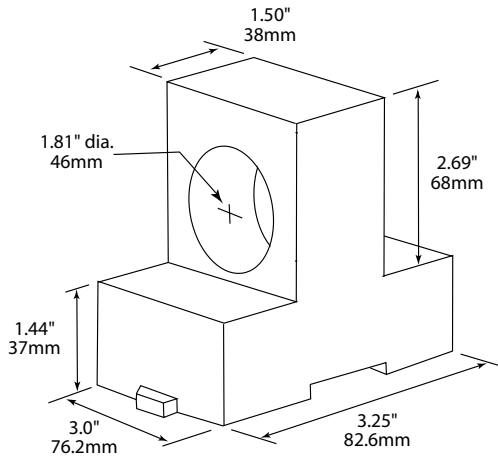

AC Current Transducer Connections

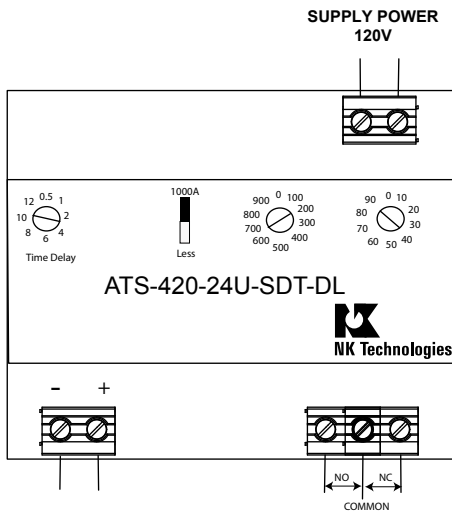

ANALOG OUTPUT SIGNAL

AC Current Transducer Output Type

Single pole, double throw relay-adjustable from 10 to 1200 A in 10 A increments. 4–20 mA signal proportional to 0–1200 A. Analog signal capped at 6 mA when trip point <150 A, 8 mA if trip point <300 A, 23 mA if the trip point is 310 or higher.

Notes:

- Dead front captive screw terminals.
- 12–22 AWG solid or stranded.
- Observe polarity.

AC Current Transducer Specifications



Power Supply	• 120 VAC (108–132 V) • 24 VAC/DC (22–26 V)
Power Consumption	<2 VA
Input Range	0–1200 A
Output Signal	4–20 mA 600 Ω max.
Output Limit	23 mA
Output Impedance	650 Ω maximum
Accuracy	1.0% FS
Analog Response Time	600 ms to 90% step change
Relay Response	200 ms to 90% step change
Hysteresis	5%
Frequency Range	10–100 Hz
Setpoint Range	10–1200 A
Output	Electromechanical SPDT relay
Output Rating	1.0 A @ 125 VAC, 2 A @ 30 VDC
Isolation Voltage	UL listed to 1270 VAC, tested to 5 KV
Case	UL94 V-0 Flammability Rated
Environmental	-4 to 122°F (-20 to 50°C) 0–95% RH, non-condensing
Listings	UL/cUL

AC Current Transducers

AC Current Transducer Ordering Information

Sample Model Number: ATS-420-SDT-24D-DL
Solid-core AC current operated switch / transducer combination, 0–1200 A range, 4–20 mA analog output, 24 VDC powered, adjustable relay trip point.

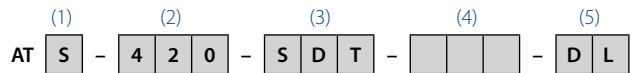

(1) Full Scale Range

S	Combination (switch and transducer)
---	-------------------------------------

(2) Output Signal

420	4–20 mA
-----	---------

(3) Contact Type

SDT	SPDT Relay
-----	------------

(4) Power Supply

24D	24 VDC
120	120 VAC

(5) Case Style

DL	Solid-core, DIN rail mounting*
----	--------------------------------

*For information on the DIN rail accessories kit, see page 128.



DC Current Transducers

Current Transducers are designed to provide an analog current reading for monitoring, data logging and panel meter applications. NK Technologies' current transducers offer a choice of 0–5 VDC, 0–10 VDC or 4–20 mA outputs common to PLC and energy management system controllers for monitoring of DC motor conditions, solar panel installations, welding processes and transportation applications.

- **DT SERIES, 4-WIRE**
 DC Current Transducers..... page 69
- **DT SERIES, 3-WIRE**
 DC Current Transducers..... page 72
- **DT SERIES, TEMPERATURE COMPENSATED**
 DC Current Transducers..... page 74
- **DT SERIES, LARGE APERTURE**
 DC Current Transducers..... page 76
- **DLT SERIES**
 DC Current Transducers..... page 78

Features:

- Jumper-selectable ranges
- Solid-core, split-core and large aperture models

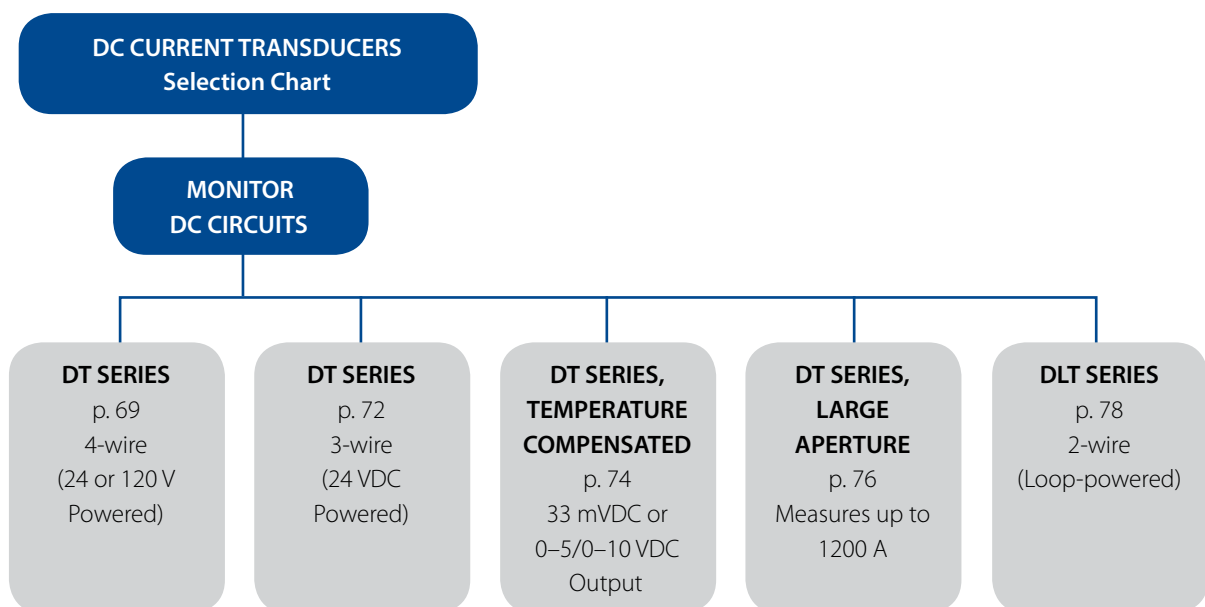

DT SERIES, 4-WIRE

DC Current Transducers

DT Series DC Current Transducers combine a Hall effect sensor and signal conditioner into a single package for use in DC current applications up to 400 A. The DT Series DC Current Transducers unipolar and bipolar models have jumper-selectable current input ranges and industry standard 0–20 mA, 4–20 mA, 0–5 VDC or 0–10 VDC outputs. These transducers are available in a split-core or solid-core case.



DC Current Transducer Applications

Battery Banks

- Monitors load current.
- Monitors charging current.
- Verifies operation.

Transportation

- Measures traction power or auxiliary loads.

Welding Processes

- Measures the current used while welding.
- Log processing time and number of operations.

Photovoltaic Panels

- Monitor panel or string current output.
- Monitor combiner box output.

DC Current Transducer Features

Single Range or Three Jumper-selectable Ranges

- Reduces set-up time.
- Reduces inventory.
- Eliminates zero and span pots.

Isolation

- Output is magnetically isolated from the input for safety.
- Eliminates insertion loss (voltage drop).

Internal Power Regulation

- Works well, even with unregulated power.
- Cuts installation cost.

Split-core Design/Built-in Mounting Brackets

- Makes installation a snap.

UL/cUL and CE Approved

- Accepted worldwide.

Battery Charging System - Bipolar Output

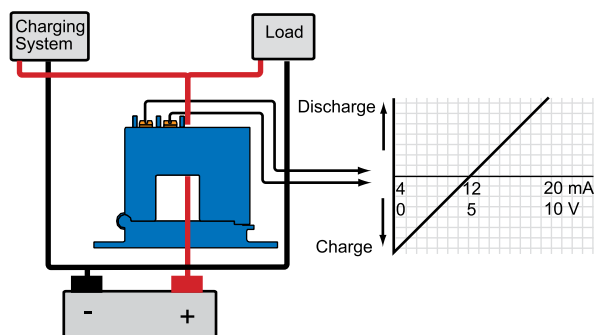

Battery Charging System - Bidirectional Output

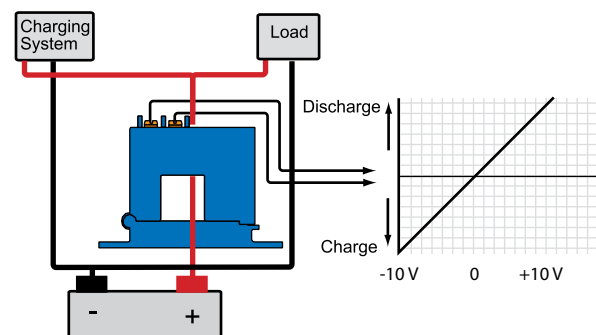

- For additional Application Examples, go to www.nktechnologies.com/applications

OEMs

Test & Evaluation Units for OEMs

Free program expedites evaluation process. See page 3 for details.



DC Current Transducer Dimensions

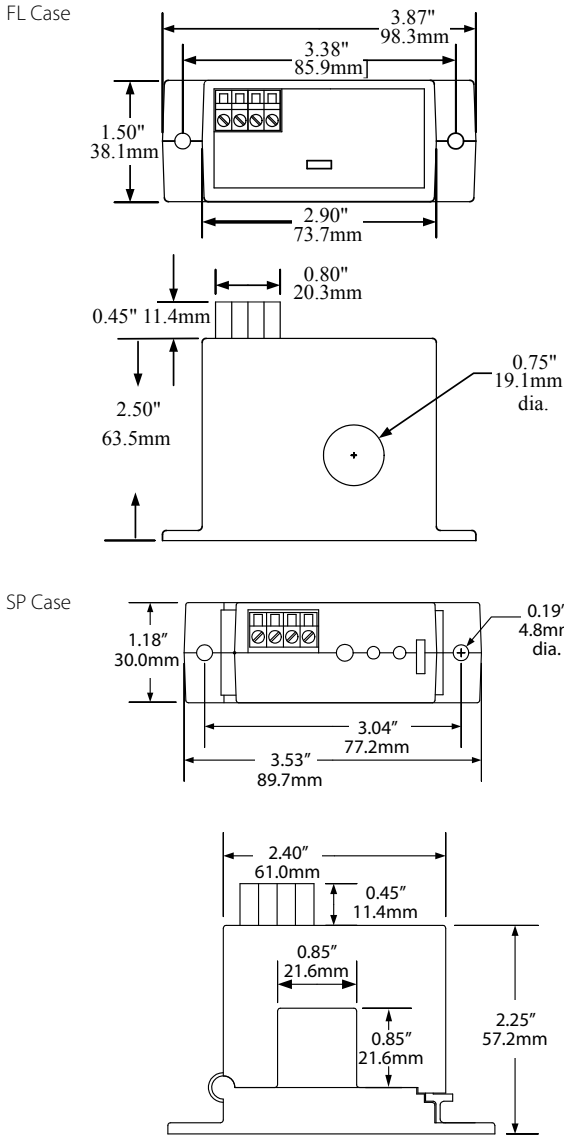

DC Current Transducer Unipolar Output

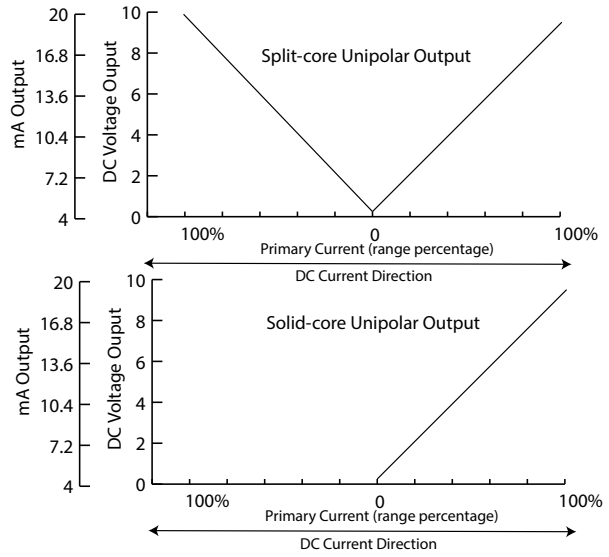

DC Current Transducer Specifications



Power Supply	<ul style="list-style-type: none"> • 120 VAC (108–132 V) solid-core only • 24 VAC/DC (22–26 V) solid-core only • 24 VAC/DC (20–45 VDC, 22–38 VAC) split-core
Power Consumption	2 VA
Output Signal	<ul style="list-style-type: none"> • 0–20 mA, 4–20 mA, 0–5 VDC, 0–10 VDC • ±10 VDC (Bidirectional models only)
Output Limit	<ul style="list-style-type: none"> • 0–20 mA, 4–20 mA: 23 mA • 0–5 VDC: 5.75 VDC • 0–10 VDC: 11.5 VDC
Output Impedance	<ul style="list-style-type: none"> • 0–20 mA, 4–20 mA: 500 max. • 0–3 or 5 VDC: 25 KΩ min. • 0–10 VDC: 50 KΩ min.
Accuracy	<ul style="list-style-type: none"> • 1.0% FS (solid-core) • 2.0% FS (split-core)
Repeatability	1.0% FS
Response Time (90% step change)	• 100 ms average (solid-core or split-core)
Frequency Range	DC
Isolation Voltage	UL listed to 1270 VAC, tested to 3 KV
Input Range	<ul style="list-style-type: none"> • 0–200 A max. (solid-core) • 0–50 A min., 0–400 A max. (split-core)
Case	UL94 V-0 Flammability Rated
Environmental	<ul style="list-style-type: none"> • -4 to 122°F (-20 to 50°C) • 0–95% RH, non-condensing
Listings	UL/cUL, CE

DC Current Transducer Connections

DT Series Unipolar and Bipolar Output Models

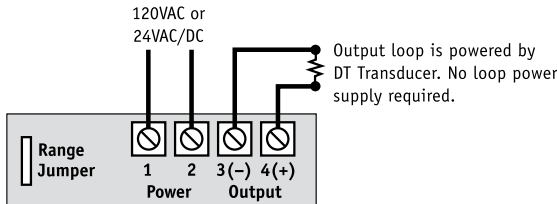

Notes:
 Deadfront captive screw terminals.
 12–22 AWG solid or stranded.
 Observe polarity.

DC Current Transducer Ordering Information

DT Series Unipolar and Bipolar Output Models, Split-Core Models

Sample Model Number: DT2-420-24U-U-SP

DC current transducer, 0–100/150/200 A range, 4–20 mA output, 24 VAC/DC powered, unipolar polarity, split-core case. (DIN rail adapters are included)

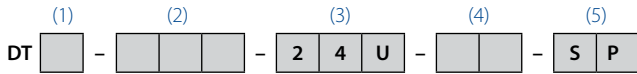

(1) Full Scale Range

1	50, 75, 100 A
2	100, 150, 200 A
3	150, 225, 300 A
4	200, 300, 400 A

(2) Output Signal

020	0–20 mA
420	4–20 mA
005	0–5 VDC
010	10 VDC

(3) Power Supply

24U	+24 VAC/DC
-----	------------

(4) Output Polarity

U	Unipolar (output with current in either direction)
BP	Bipolar

(5) Case Style

SP	Split-core
----	------------

DT Series Unipolar and Bipolar Output Models, Solid-Core Models

Sample Model Number: DT2-420-24U-U-FL

DC current transducer, 0–100/150/200 A range, 4–20 mA output, 24 VAC/DC powered, unipolar polarity, solid-core case. (DIN rail adapters are included)

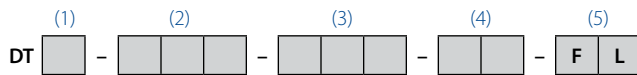

(1) Full Scale Range

0	5, 10, 20 A
1	50, 75, 100 A
2	100, 150, 200 A

(2) Output Signal

020	0–20 mA
420	4–20 mA
005	0–5 VDC
010	10 VDC

(3) Power Supply

24U	+24 VAC/DC
120	120 VAC

(4) Output Polarity

U	Unipolar (output with current in one direction only)
BP	Bipolar

(5) Case Style

FL	Solid-core
----	------------

DT Series Bidirectional Output Models

Sample Model Number: DT2-010-24D-BD-SP

DC current transducer, 0–200 A range, ±10 VDC output signal, 24 VDC powered, split-core case. (DIN rail adapters are included)

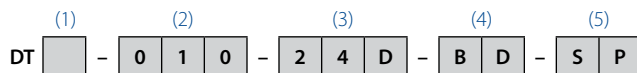

(1) Full Scale Range

1	100 A
2	200 A
3	300 A
4	400 A

(2) Output Signal

010	±10 VDC
-----	---------

(3) Power Supply

24D	24 VDC
-----	--------

(4) Output Polarity

BD	Bidirectional
----	---------------

(5) Case Style

SP	Split-core
----	------------



DT SERIES, 3-WIRE

DC Current Transducers

DT Series DC Current Transducers provide a low cost way of measuring DC current in a small and easy-to-install case. The series is stable at a wide range of temperatures. The single range design and the use of a common for the power supply and output signal provide a price competitive option in an international market. Similar in concept to the DLT current output sensors, this design produces your choice of 0–5 or 0–10 VDC to interface with controllers or data acquisition systems lacking the current signal capacity.



DC Current Transducer Applications

Photovoltaic Panel Monitoring

- Accurate and reliable indication of how much power is produced by a single panel or a string of panels.

Hoists

- Detect overloads and jams.
- Detect undercurrent conditions from coupling slip or breakage.

DC Motor Protection

- Detect imminent bearing failures.

Wind Driven Generators

- Measure and monitor power production from alternative sources.

DC Current Transducer Features

Industry Standard Outputs

- 0–5 or 0–10 VDC proportional to the DC current.
- Compatible with most automation systems.

24 VDC Powered

- Supply and Output share common.

No Span or Zero Adjustments Needed

- Reduces field calibration errors.
- Factory calibrated without potentiometers.

Solid-core Case

- Compact size requiring very little panel space.

Built-in Mounting Feet

- Simple, two-screw panel mounting or attach with DIN rail brackets (included).*

Designed for UL/cUL and CE Approval

- Accepted worldwide.

*For information on the DIN rail accessories kit, see page 128.

Monitoring a Photovoltaic Panel Power Output

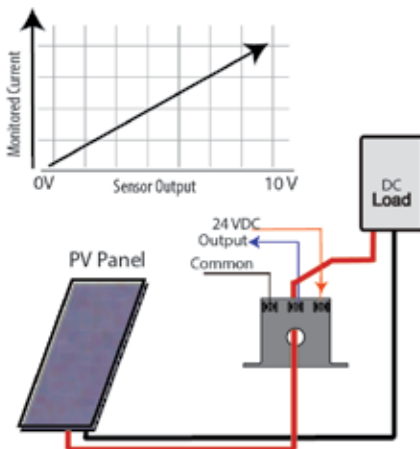

OEMs Test & Evaluation Units for OEMs
Free program expedites evaluation process. See page 3 for details.

- For additional Application Examples, go to www.nktechnologies.com/applications

DC Current Transducer Dimensions

FF Case

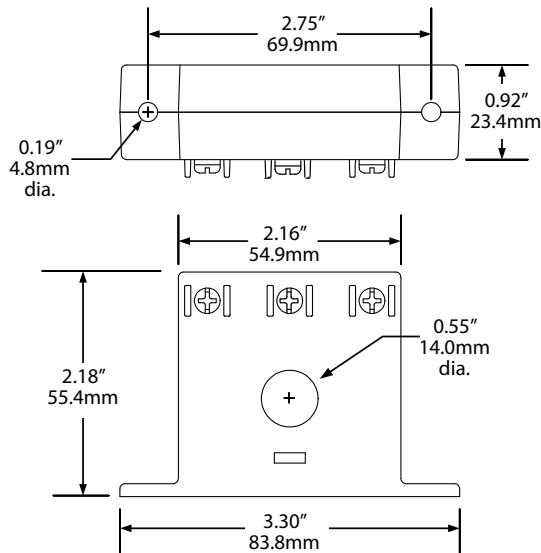

DC Current Transducer Connections

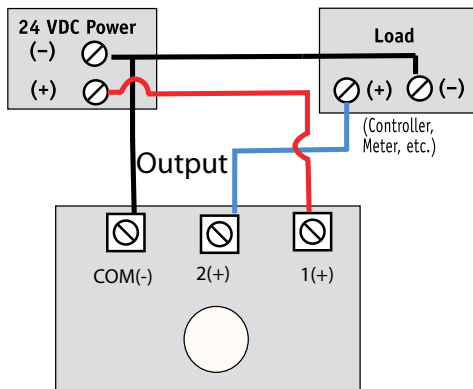

DC Current Transducer Specifications

Power Supply	24 VDC (19–30 V)
Power Consumption	<2 VA
Output Signal	0–5 or 0–10 VDC
Output Impedance	10 KΩ min.
Response Time	500 ms
Range	• 0–50 A • 0–100 A
Frequency Range	DC
Isolation Voltage	UL listed to 1270 VAC, tested to 5 KV
Case	UL94 V-0 Flammability Rated
Environmental	-4 to 122°F (-20 to 50°C) 0–95% RH, non-condensing
Listings	Designed for UL/cUL and CE approval

DC Current Transducer Ordering Information

Sample Model Number: DTB-010-24D-U-FF

DC current transducer, 0–50 A, 0–10 VDC output, 24 VDC powered, unipolar, solid-core case. (DIN rail adapters are included)

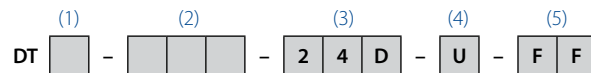

(1) Range

B	0–50 ADC
C	0–100 ADC

(2) Output Type

005	0–5 VDC
010	0–10 VDC

(3) Power Supply

24D	24 VDC
-----	--------

(4) Output Design

U	Unipolar (output with current in one direction)
---	---

(5) Case Style

FF	Solid-core, front terminals
----	-----------------------------



DT SERIES, TEMPERATURE COMPENSATED DC Current Transducers

The DT Series of Temperature Compensated DC Current Transducers is ideal for energy management system inputs where the controller is designed to accept 333 mV signals, commonly found in power monitoring applications. Other output options available are a 0–5 VDC signal used in building energy management systems or a 0–10 VDC signal seen more often in industrial controllers. Additionally, this series features a patent-pending method that improves the sensor accuracy as the ambient temperature changes. The sensor output is automatically adjusted as the temperature increases or decreases, eliminating one of the biggest issues with Hall effect based products.

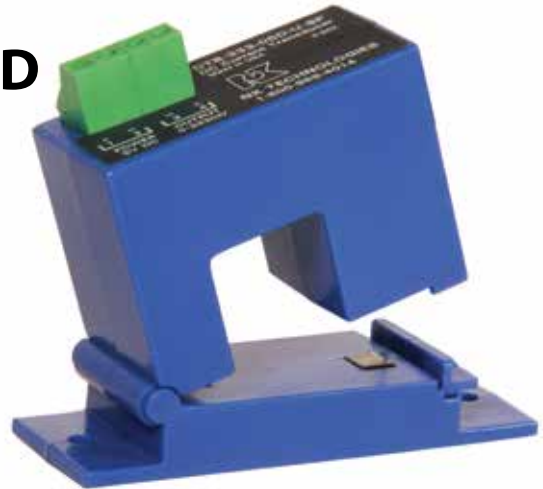

Patent-pending temperature compensation design.

DC Current Transducer Applications

Photovoltaic Panel Output Measurement

- The sensor output rises and falls as the panel produces more or less power.

DC Motors

- Detects jams and overloads.
- Provides early notification of impending bearing failure.

Electrical Heaters

- Detects open or shorted elements quickly.

Photovoltaic Panel Output Measurement

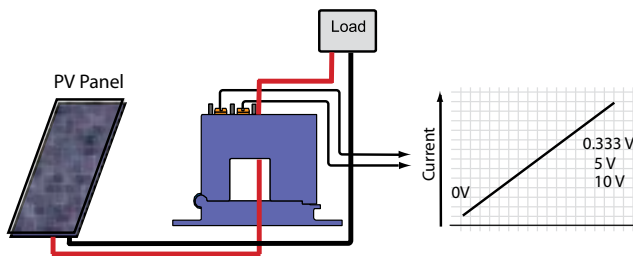

The DT sensor will produce a signal directly proportional to the current produced by the panel or string of panels, with an output to match the controller being used.

- For additional Application Examples, go to www.nktechnologies.com/applications

DC Current Transducer Features

Voltage Output

- 333 mVDC, 5 or 10 VDC proportional to DC current.
- Compatible with many monitoring systems.

5 VDC Powered

- Use with data collection systems.
- Available with 333 mVDC output.

12 VDC Powered

- Available with 0.333, 5 or 10 VDC output.

Ranges to Suit Your Needs

- 0–50 A DC.
- 0–100 A DC.

Temperature Compensated

- Remains accurate with rise or fall of ambient temperature.

Built-in Mounting Feet

- Simple, two-screw panel mounting or attach with DIN rail brackets (included).*

Split-core Case

- Open to snap the sensor over existing conductor; no need to disconnect the load to install.

Designed for UL/cUL Approval

- Accepted worldwide.

*For information on the DIN rail accessories kit, see page 128.

OEMs Test & Evaluation Units for OEMs
Free program expedites evaluation process. See page 3 for details.

DC Current Transducer Dimensions

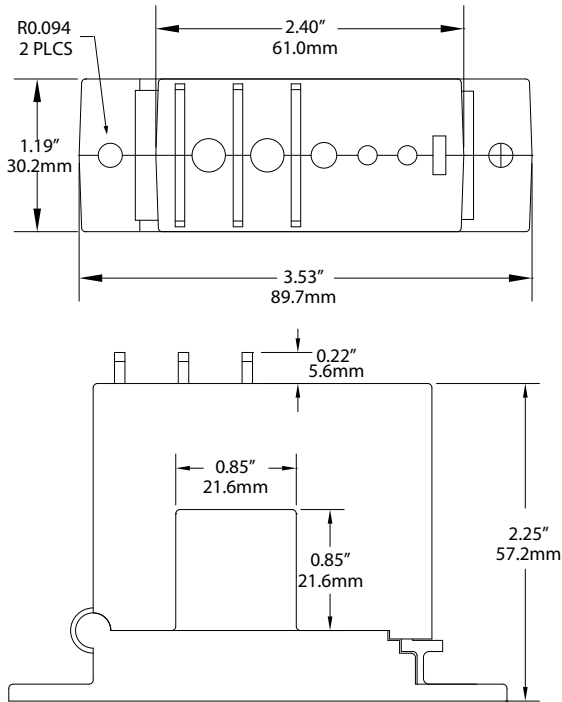

DC Current Transducer Connections

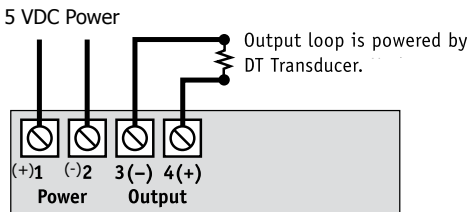

DC Current Transducer Output Type

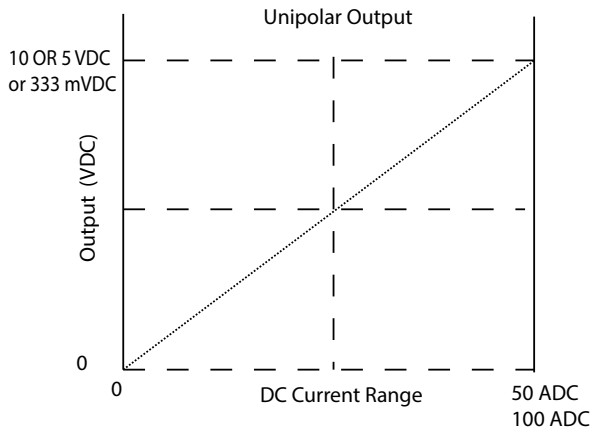

Output remains accurate even as the temperature rises and falls from -20°C to +50°C (-4 to +122 °F) with our patent pending design.

DC Current Transducer Specifications

Power Supply	5 VDC (5.1–5.9 V)	12 VDC (11.5–13.2 V)
Power Consumption	<8.5 mA (no load) (333 mVDC output)	<2 VA
Output Signal	0–333 mVDC	0–5 VDC or 0–10 VDC
Output Impedance	50 Ω minimum, 20 mA maximum (333 mVDC)	10 KΩ minimum (0–5 or 0–10 VDC output)
Accuracy	1.0% full scale across temperature range	
Response Time	400 ms (90% step change)	
Frequency Range	DC	
Isolation Voltage	UL listed to 1270 VAC, tested to 5 KV	
Case	UL94 V-0 Flammability Rated	
Environmental	-4 to 122°F (-20 to 50°C) 0–95% RH, non-condensing	
Listings	Designed for UL/cUL approval	

DC Current Transducer Ordering Information

Sample Model Number: DTB-333-05D-U-SP

Split-core DC current transducer, 0–50 A range, 0–333 mVDC, 5 VDC powered, unipolar output. (DIN rail adapters are included)

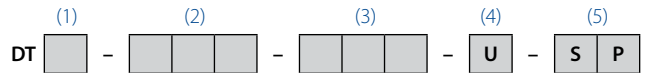

(1) Range	
B	0–50 A
C	0–100 A
(2) Output Signal	
333	333 mVDC
005	5 VDC
010	10 VDC
(3) Power Supply	
05D	5 VDC (0–0.333 VDC output only)
12D	12 VDC (0–0.333, 0–5 or 0–10 VDC output only)
(4) Signal Response Type	
U	Unipolar (output with current in one direction only)
(5) Case Style	
SP	Split-core



DT SERIES, LARGE APERTURE DC Current Transducers

DT Series Large Aperture DC Current Transducers combine a Hall effect sensor and signal conditioner into a single package for use in DC current applications up to 1200 A. The DT Series Large Aperture Transducers have factory set and calibrated ranges, industry standard 4–20 mA, 0–5 VDC or 0–10 VDC outputs, and are available in solid-core DIN rail mounting case.



DC Current Transducer Applications

Battery Banks

- Monitor load and charging currents.
- Verify operation.

Transportation

- Measure traction power or auxiliary loads.

Wind and Solar Generated Power

- Measure the current produced or consumed.
- Detect mechanical problems before failure occurs.

Monitor DC Powered Motors

- Monitor current of cranes, saws, sorters and positioning equipment.

DC Current Transducer Features

Factory Set and Calibrated Ranges

- No need for field calibration.
- Eliminates zero and span pots.

Isolation

- Output is magnetically isolated from the input for safety.
- Eliminates insertion losses, no added burden.

Internal Power Regulation

- Works well, even with unregulated power.
- Cuts installation cost.

DIN Rail Mounted Case*

- Makes installation a snap.
- No drilling or screws to lose.
- Optional DIN rail kit available for chassis mounting.*

UL/cUL and CE Approved

- Accepted worldwide.

*For information on the DIN rail accessories kit, see page 128.

Battery Charging System

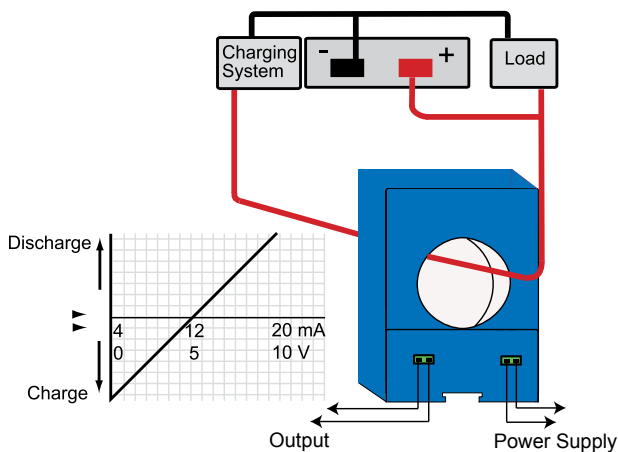

For additional Application Examples, go to www.nktechnologies.com/applications

OEMs

Test & Evaluation Units for OEMs

Free program expedites evaluation process. See page 3 for details.

DC Current Transducer Dimensions

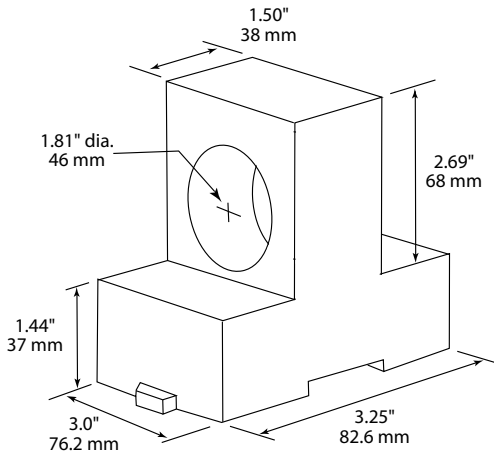

DC Current Transducer Connections

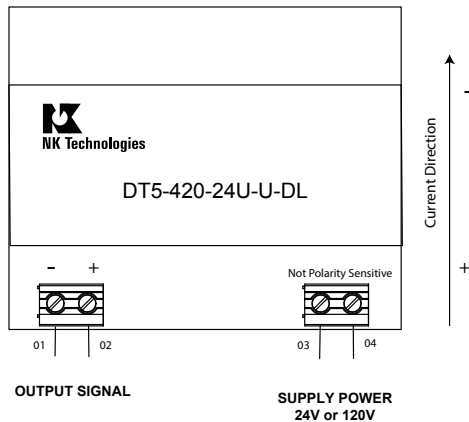

DC Current Transducer Output Type

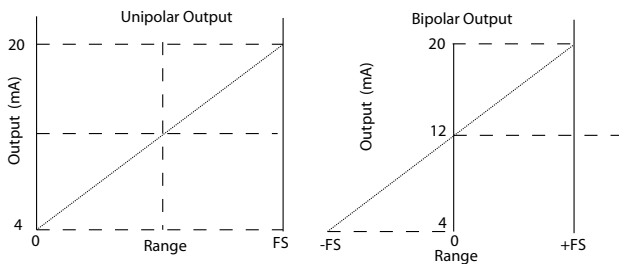

Notes:
 Deadfront captive screw terminals.
 12–22 AWG solid or stranded.
 Observe polarity.
 Unipolar Output: Signal With Current flowing in one direction only.

DC Current Transducer Specifications



Power Supply	• 120 VAC (108–132 V) • 24 VAC/DC (22–26 V)
Power Consumption	2 VA
Output Signal	4–20 mA, 0–5 VDC, 0–10 VDC
Output Limit	• 4–20 mA: 23 mA • 0–5 VDC: 5.75 VDC • 0–10 VDC: 11.5 VDC
Output Impedance	• 4–20 mA: 650 Ω max. • 0–5 VDC: 25 KΩ min. • 0–10 VDC: 50 KΩ min.
Accuracy	2.0% FS
Repeatability	1.0% FS
Response Time	100 ms (to 90% of step change)
Range	0–1200 A DC
Frequency Range	DC
Isolation Voltage	UL listed to 1270 VAC, tested to 3 KV (monitored line to output)
Case	UL94 V-0 Flammability Rated
Environmental	-4 to 122°F (-20 to 50°C) 0–95% RH, non-condensing
Listings	UL/cUL, CE

DC Current Transducers

DC Current Transducer Ordering Information

Sample Model Number: DT6-420-24U-U-DL
 Solid-core DC current transducer, 0–500 A range, 4–20 mA, 24 VAC/DC powered, unipolar output.

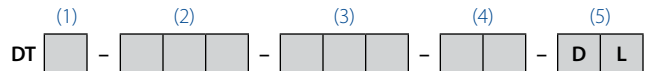

(1) Full Scale Range		(3) Power Supply	
5	300 A	24U	+24 VAC/DC
6	500 A	120	120 VAC
7	750 A		
8	1000 A		
9	1200 A		
(2) Output Signal		(4) Output Polarity	
420	4–20 mA	U	Unipolar
005	0–5 VDC	BP	Bipolar
010	0–10 VDC		
		(5) Case Style	
		DL	Solid-core, DIN rail mounting



DLT SERIES

DC Current Transducers

DLT Series DC Current Transducers combine a Hall effect sensor and a signal conditioner into a single package. The DLT Series DC Current Transducers are designed to produce an analog 4–20 mA signal proportional to the DC current in the primary conductor. These transducers are available in a solid-core or split-core case design. Lower current ranges make this sensor ideal for use in photovoltaic panel combiner boxes.



DC Current Transducer Applications

DC Current Monitoring

- PV Array combiner boxes.
- Wind generators.
- DC heating applications.
- UPS system monitoring.

Photovoltaic Arrays

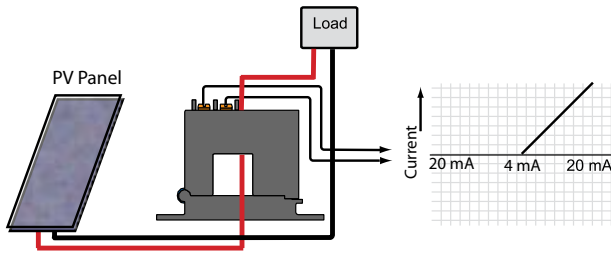

- For additional Application Examples, go to www.nktechnologies.com/applications

DC Current Transducer Features

4–20 mA Loop-powered Output

- Industry standard connections, positive indication of correct field wiring.

Single Range

- No chance of field range selection errors.
- Eliminates zero and span pots.

Isolation

- Output is magnetically isolated from the primary circuit for safety.
- Eliminates insertion loss (voltage drop).

UL/cUL and CE Approved

- Accepted worldwide.

Monitoring PV Arrays:

The current produced by a photovoltaic module or array can be easily monitored by using the DLT series current sensors over the conductor exiting the collectors. Using a simple two-wire connection powered by 24 VDC nominal in series with the sensor output, the sensor will produce a signal in real time that is directly proportional to the current being produced by the PV module.

If a single cell fails, or a module quits operating properly, the current output will drop, and the current sensor will reflect the change.

Safer and more stable than shunts, non-contact current sensors are a simple answer to measuring DC current at any point in the PV system.

OEMs Test & Evaluation Units for OEMs
Free program expedites evaluation process. See page 3 for details.

DC Current Transducer Dimensions

FF Case

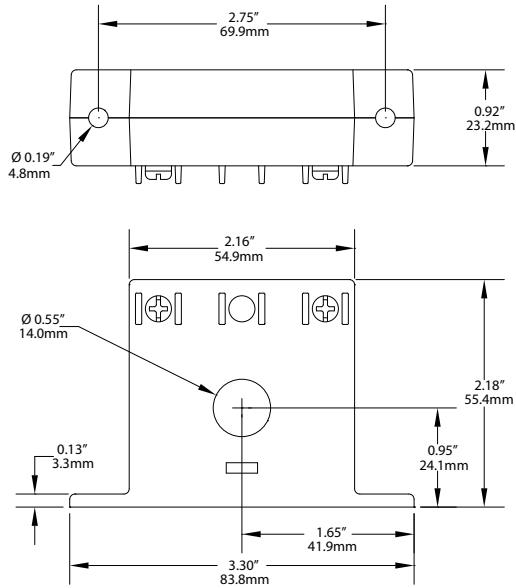

SP Case

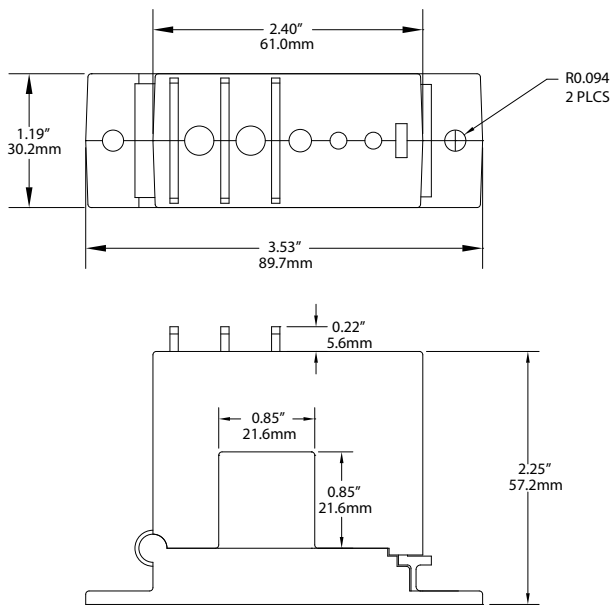

DC Current Transducer Connections

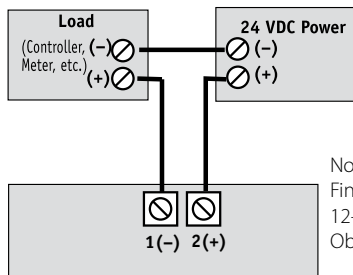

Notes:
Fingersafe captive screw terminals.
12–22 AWG solid or stranded.
Observe polarity.

4-20 mA Output

DC Current Transducer Specifications



Power Supply	24 VDC (12–40 V)
Output Signal	4–20 mA, loop-powered
Output Limit	23 mA
Accuracy	1.0% FS
Response Time	100 ms (to 90% step change)
Range	0–20 to 0–400 DC, see ordering information
Frequency Range	DC
Isolation Voltage	UL listed to 1270 VAC, tested to 5 KV
Case	UL94 V-0 Flammability Rated
Environmental	-4 to 122°F (-20 to 50°C) 0–95% RH, non-condensing
Listings	UL/cUL, CE

DC Current Transducer Ordering Information*

Sample Model Number: DLTB-420-24L-BP-FF

DC current transducer, 50 A range, 4–20 mA output, 24 VDC loop-powered in a solid-core case. (DIN rail adapters are included)

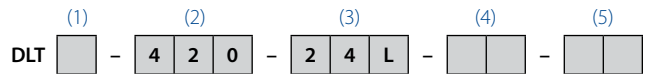

(1) Full Scale Range

A	0–20 A
B	0–50 A
C	0–100 A
D	0–200 A
E	0–300 A
F	0–400 A

(2) Output Signal

420	4–20 mA
-----	---------

(3) Power Supply

24L	24 VDC loop-powered
-----	---------------------

(4) Output Polarity

U	Unipolar
BP	Bipolar

(5) Case Style (black only)

FF	Solid-core, front terminals (max. range 0–100 A)
SP	Split-core (min. range 0–50 A)

*Bulk packaging only.

DC Current Transducers



Ground Fault Protection

Detecting ground fault conditions and protecting sensitive equipment or personnel from harm are where AG Series sensors can help. A compact design eliminates two-piece solutions while options include factory-set or field-adjustable trip point; N.O. or N.C. latching or auto-reset relays, 24/120/240 V power supply and noise immunity.

- **AG SERIES**
Ground Fault (Earth Leakage) Detectors..... page 82
- **AGL SERIES**
Large Aperture Ground Fault Relays..... page 86
- **AGLD SERIES**
Ground Fault Relay with Digital Display..... page 89
- **AGT SERIES**
Ground Fault Indicators..... page 91
- **DG SERIES**
DC Ground Fault RelaypageAddendum 92A

Features:

- N.O./N.C. solid-state switch or mechanical relay outputs
- Field-selectable 5 mA, 10 mA or 30 mA setpoints
- Noise immunity option for EMI/RFI sensitive environments
- UL, CE approved

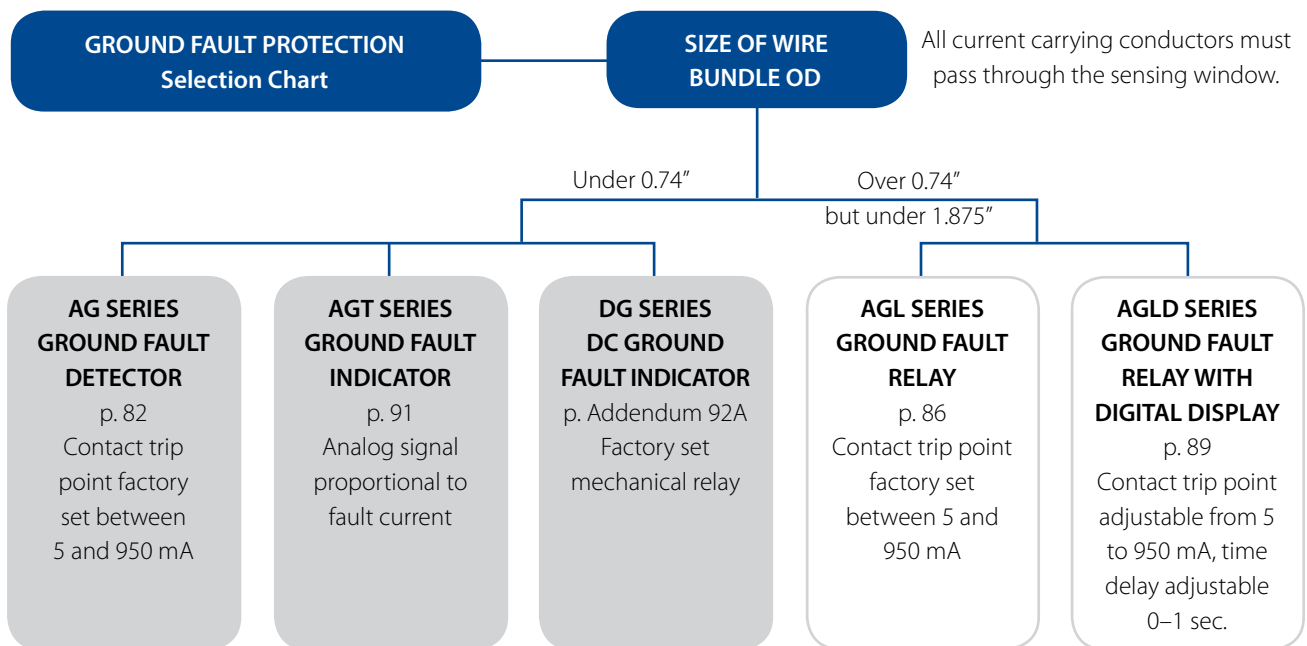

Earth Fault Detection Requirements

In North America, most people are familiar with ground fault circuit interrupters (GFCI) since they have been required by the National Electric Code (NEC) since the late 1960's. As the technology became more reliable, ground fault circuit interrupters were required in many more applications. The primary purpose was to reduce the number of deaths caused by electrical shock. Any place where a human body might become the best path to ground is a candidate for ground fault circuit protection. The number of fatalities reduced significantly.

GFCI receptacles and circuit breakers were a huge step forward. With the success in protecting people from shock the interest in ground fault protection increased. A GFCI is designed to disconnect a circuit if current to earth exceeds 6 mA at 120 VAC in locales where the NEC sets the standard for wiring practices. At this low level of fault current it may take a few seconds (UL943A states just under six seconds maximum) before the circuit is de-energized, but if the fault becomes more dangerous, at 20 mA or higher, the circuit is disconnected much faster.

Underwriters Laboratories has established standards under UL943 for personnel protection (avoiding shock to humans) and also for equipment protection at various fault levels and reaction time limits. The point of equipment protection is to keep a fault from damaging the machine more than protecting the operator. Circuits supplying heating loads (heat strips, heat trace and snow melting equipment) are usually not disconnected until the fault current exceeds 30 mA or more. Electric vehicle charging stations have GFCI protection required, but the fault level is somewhere between standard personnel protection and the various levels of equipment protection, and not specified in the NEC.

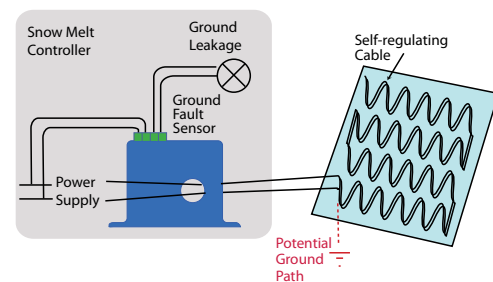

The NEC states the following:

NEC section 427.22. Ground-fault protection of equipment shall be provided for electric heat tracing and heating panels. This requirement shall not apply in industrial establishments where there is alarm indication of ground faults and the following conditions apply: (1) Conditions of maintenance and supervision ensure that only qualified persons service the installed systems. (2) Continued circuit operation is necessary for safe operation of equipment or processes.

NEC section 426.28. Ground-fault protection of equipment shall be provided for fixed outdoor electric deicing and snow-melting equipment.

NEC section 555.3. The over current protective devices that supply the marina, boat yards, and commercial and noncommercial docking facilities shall have ground-fault protection not exceeding 30 mA.

There is no stated fault current limit in section 427.22 for heating equipment or in 426.28 covering snow melt systems, but section 555.3 for protection at docks clearly shows that the monitored circuit must be disconnected from the load if there is a fault over 30 mA.

The NEC calls for ground fault protection for high current supplies too. Sections 215.10 and 230.95 deal with current of 1000 amps and voltages of 480 or higher. Section 517.17 stipulates where fault detection is required in hospitals and other health care facilities.

The importance of protecting an electrical system against faults to earth cannot be overstated. The NEC sections referred to above are just the beginning of equipment protection. This type of fault sensing is not over current detection, so fusing or circuit breakers will keep the conductors or their insulation from being damaged. There are a wide range of applications where ground fault detection is required, but if circuit size is reviewed, most personnel protection is needed for 15 or 20 amp circuits supplied at 120 volts. The requirements for equipment protection vary widely.

NK Technologies offers a ground fault sensor with simple installation and the lowest cost. Rather than combining a detector with a circuit interrupter, the sensor provides contacts to open or close when a fault is detected. The contacts can be used to energize a shunt trip accessory on a circuit breaker, de-energize a contactor coil, or trigger an alarm if the process being monitored should only be stopped in an orderly manner.

OEMs

Test & Evaluation Units for OEMs

Free program expedites evaluation process. See page 3 for details.



AG SERIES

Ground Fault (Earth Leakage) Detectors

AG Series Ground Fault Detectors help protect people, products, and processes from damage by ground fault conditions by monitoring all current-carrying conductors in grounded single- and three-phase delta or wye systems.



Ground Fault Protection

Ground Fault Protection Applications

Personnel Protection (typically 5 mA)

- Detects sensitive ground fault conditions, which may be injurious to personnel and processes.
- Functions as sensor and alarm trigger when part of an overall ground fault protection system.

Equipment Protection (typically 10 mA or 30 mA)

- For applications where personal protection is not the primary concern, higher setpoint capability helps eliminate nuisance tripping while still providing adequate ground fault detection to protect machine electronics.

Regulatory

- Meets requirements as stipulated by governmental and industrial regulatory groups for ground fault sensing.

Ground Fault Protection Features

Broad Range of Options to Match Application Needs

- N.O./N.C. solid-state switch or mechanical relay outputs.
- Normally energized or normally de-energized contacts.
- Noise Immunity option for use in EMI/RFI sensitive environments.

Setpoint Options Maximize Ease-of-Use

- Field-selectable 5 mA, 10 mA or 30 mA setpoints on the AG3 “Tri-set” model makes user adjustments fast, sure and convenient.
- Single factory-calibrated setpoints available from 5 mA to 950 mA.

Compatible with Standard Equipment

- Applicable on single- and three-phase systems.
- Ideal for use with shunt trip breakers.
- Magnetically isolated from monitored circuit and control power.

UL/cUL and CE Approved

- Accepted worldwide.

Insulation Breakdown Monitoring

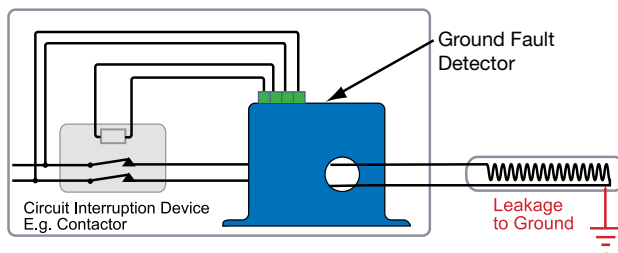

- For additional Application Examples, go to www.nktechnologies.com/applications

“Zero Sum” Operating Principle:

In three-phase delta and wye systems, under normal conditions current in the ‘hot’ leg of a two-wire load is equal in magnitude but opposite in sign to the current in the neutral leg. As a result, the electromagnetic fields surrounding these two conductors cancel, producing a “zero sum current.” As soon as current leaks to ground (fault condition) the two currents become imbalanced and a net magnetic field results. AG Series detectors monitor this field and trip alarm contacts when the leakage rises above setpoint.



Solid-state Outputs



Mechanical Outputs

Available Models

AG Series with Solid-state Outputs offer the benefit of reliable, long-lasting solid-state switches. Solid-state design provides unlimited switch operating life, superior resistance to shock and vibration, zero off-state leakage, high switch speeds and high input-output isolation. Available in solid-core case with screw terminals.

AG Series with Mechanical Outputs are available in solid-core cases with a choice between a N.O. or N.C. SPST latching relay and a SPDT Form C relay with auto-reset. All mechanical models can be ordered with factory-set, field-adjustable setpoint or with a “Tri-set” option, which provides three factory-set setpoints. A noise immunity option is available for applications in harsh EMI/RFI environments.

Output Tables

Normally Energized Models (-FS Option and -ENE Option)

Protection from faults and control power loss.

	Control Power Applied		
	No Power	No Fault	Fault
N.C. Normally Closed	closed	open	closed
N.O. Normally Open	open	closed	open

Normally De-energized Models (-NF and -DEN Options)

Protection from faults only when power is applied.

	Control Power Applied		
	No Power	No Fault	Fault
N.C. Normally Closed	closed	closed	open
N.O. Normally Open	open	open	closed

Latching Models (-LA Option)

power up initially in the rest (normal) mode. If there is a fault condition or the test button is pushed, the output contacts will change state and latch. The output will remain latched regardless of whether the fault is cleared or control power is removed. To reset the output apply a momentary contact across “reset” terminals.

OEMs Test & Evaluation Units for OEMs
Free program expedites evaluation process. See page 3 for details.



Ground Fault Protection Dimensions

Solid-State

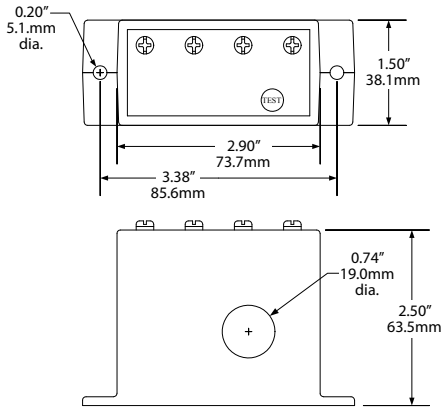

Mechanical

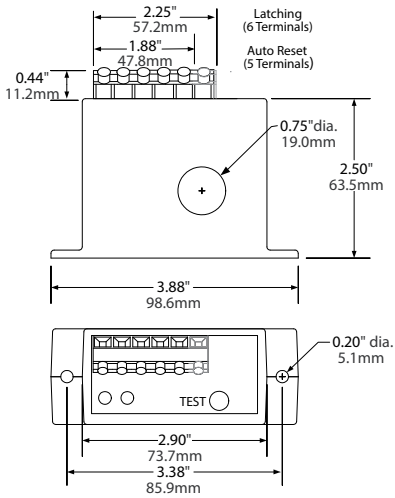

Connections

AG Series Solid-State Switch

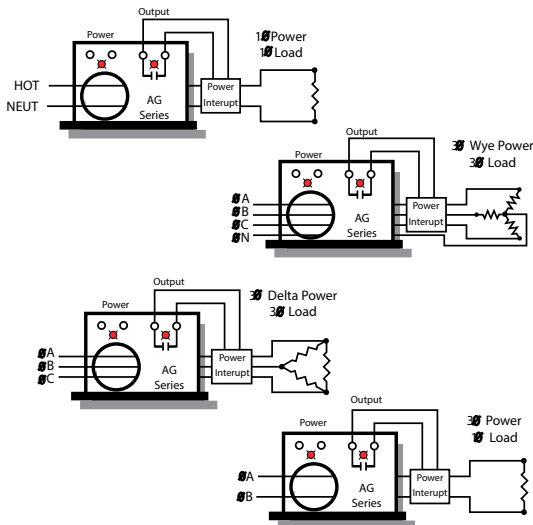
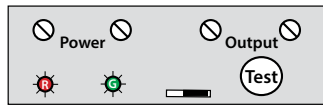

AG Series Mechanical Relay

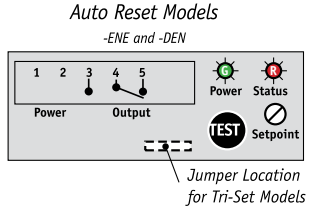
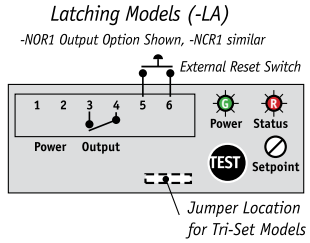

Ground Fault Protection Specifications



Power Supply	<ul style="list-style-type: none"> • 120 VAC (66–132 V) • 24 VAC/DC (19–29 V) • Green LED = Power On indication 	
Power Consumption	2 VA max.	
Setpoint Range	Factory-calibrated models (specify when ordering): <ul style="list-style-type: none"> • AG1: 5–100 mA (005–100) • AG2: 80–950 mA (080–950) TR3 “Tri-set” models (field jumper select): <ul style="list-style-type: none"> • AG3: 5, 10, or 30 mA 	
	SOLID-STATE OUTPUT MODELS	MECHANICAL OUTPUT MODELS
Output	Isolated solid-state relay	Electromechanical SPDT relay
Output Rating	<ul style="list-style-type: none"> • Solid-state AC Switch 1 A @ 240 VAC • Solid-state DC Switch 0.15 A @ 30 VDC 	<ul style="list-style-type: none"> • Auto Reset: SPDT Relay 1 A @ 125 VAC, 2 A @ 30 VDC • Latching: SPST Relay 1 A @ 125 VAC, 2 A @ 30 VDC
Off-state Leakage	<ul style="list-style-type: none"> • <10 micro A (N.O.) • <2.5 mA (N.C.) 	none
Response Time	<ul style="list-style-type: none"> • 200 ms @ 5% above trip point • 60 ms @ 50% above trip point • 15 ms @ 500% above trip point 	
Time Delay	None	
Isolation Voltage	UL listed to 1270 VAC, tested to 5 KV	
Frequency Range	50–400 Hz (monitored circuit)	
Noise Immunity	N/A	<ul style="list-style-type: none"> • EMI/RFI shielding • Power supply noise filtering
Case	UL94 V-0 Flammability Rated	
Environmental	-4 to 122°F (-20 to 50°C) 0–95% RH, non-condensing	
Listings	UL/cUL, CE	

Ground Fault Protection Ordering Information

Solid-state Output Models

Sample Model Number: AG1-NOAC-120-FS-005
 Ground fault detector with normally open solid-state contact output, 120 VAC power supply, 5 mA trip point, failsafe version.

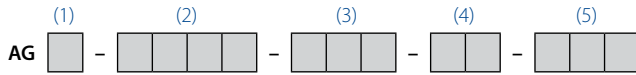

(1) Setpoint Range

1	5–100 mA factory set
2*	80–950 mA factory set
3	5/10/30 mA jumper set

*Not UL recognized in any configuration.

(2) Output Type

NOAC	Normally Open, 1 A @ 240 VAC
NCAC	Normally Closed, 1 A @ 240 VAC
NODC	Normally Open, 0.15 A @ 30 VDC
NCDC	Normally Closed, 0.15 A @ 30 VDC

(3) Power Supply

120	120 VAC
24U*	24 VAC/DC
240*	240 VAC

*Not UL recognized in any configuration.

(4) Options

FS	Normally energized
NF	Normally de-energized

(5) Setpoint

TR3	Tri-set
005 to 950	Factory set trip point in mA

Mechanical Output Models

Sample Model Number: AG1-NOR1-120-LA-005
 Ground fault detector with normally open SPST latching relay output, 120 VAC power supply and 5 mA trip point.

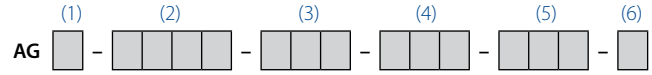

(1) Setpoint Range

1	5–100 mA factory set
2	80–950 mA factory set
3	5/10/30 mA jumper set

(2) Output Type

NCR1	Normally Closed SPST Relay Form B (Available only with -LA option)
NOR1	Normally Open SPST Relay Form A (Available only with -LA option)
SDT1	SPDT Relay (Form C) with auto-reset (Available only with -DEN and -ENE options)

(3) Power Supply

120	120 VAC
24U	24 VAC/DC

(4) Options

ENE	Normally energized, auto-reset (SDT1 output only)
DEN	Normally de-energized, auto-reset (SDT1 output only)
LA	Latching (NOR1 and NCR1)

(5) Setpoint

TR3	Tri-set
005 to 950	Factory set trip point in mA

(6) Noise Immunity

N	Noise immunity
	None (blank)

OEMs Test & Evaluation Units for OEMs
 Free program expedites evaluation process. See page 3 for details.



AGL SERIES

Large Aperture Ground Fault Relays

AGL Series are large aperture ground fault relays that offer one of the largest aperture diameters in the industry while maintaining a compact overall profile. Intended for sensing earth leakage in applications up to 300 A, the AGL Series offers a choice of N.O. or N.C. latching relays or an SPDT Form C relay with auto-reset. Case features integral DIN rail mounting as standard and optional noise immunity coatings for applications in harsh EMI/RFI environments.



Ground Fault Protection

Ground Fault Protection Applications

- Replace bulky two-piece sensor solutions which require separate CTs or relay modules.
- Use with shunt trip breakers to provide total ground fault protection to sensitive machine electronics.
- Detect ground faults in resistance/impedance heating, industrial automation and control, theatrical lighting, portable power distribution, and snow melt/heat trace applications.
- Sense progressive levels of ground fault in motors or heating systems to detect deterioration prior to catastrophic failure.

Moisture Ingress on a Submersible Pump Motor

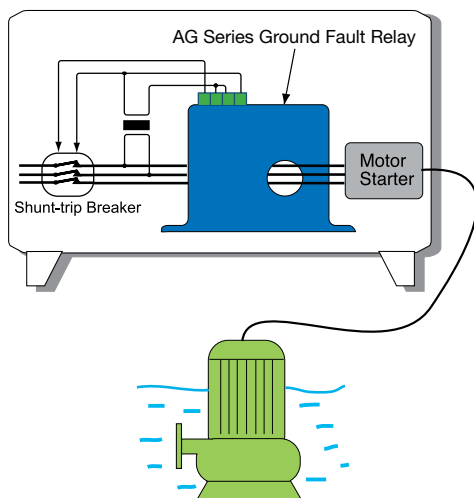

- For additional Application Examples, go to www.nktechnologies.com/applications

Ground Fault Protection Features

- Integral DIN rail mount with spring loaded mounting clips.*
- Setpoint options include factory-adjustable setpoint from 5 mA – 100 mA or “TR3 Tri-Set” models with field-selectable 5/10/30 mA settings.
- Finger-safe terminals for worry-free installation and operation.
- Aperture orientation is perpendicular to DIN rail, allowing for clean and efficient wiring and minimizing space between multiple components.
- Choice of dependable latching SPST or SPDT (form C) electromechanical relay outputs.
- Uses “Zero Sum” operating principle to reliably sense imbalance in magnetic fields associated with current leakage to ground.
- Typical response times from 15 ms to 200 ms.
- Integral “push-to-test” button with LED indication of contact status.
- UL/cUL and CE Approved. Accepted worldwide.

*For information on the DIN rail accessories kit, see page 128.

Ground Fault Protection Dimensions

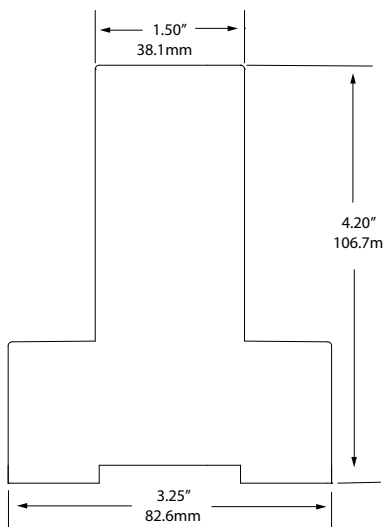
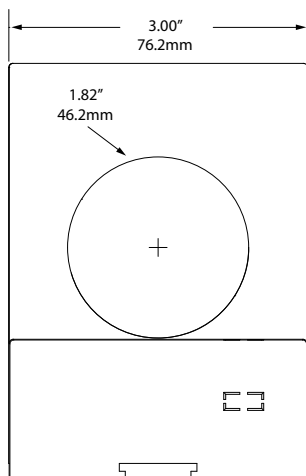

Ground Fault Protection Connections

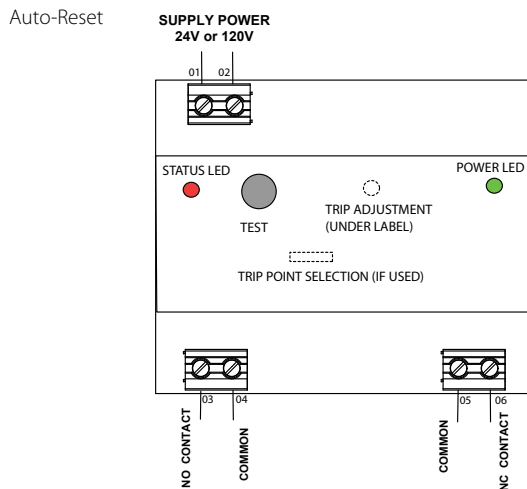

Latching

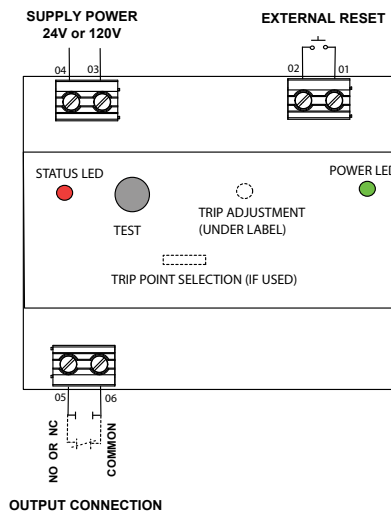

OEMs Test & Evaluation Units for OEMs
Free program expedites evaluation process. See page 3 for details.



Ground Fault Protection Specifications



Power Supply	<ul style="list-style-type: none"> • 120 VAC (66–132 V) • 24 VAC (19–29 V)
Power Consumption	<2 VA
Setpoint Range	Factory-calibrated models (specify when ordering): <ul style="list-style-type: none"> • AGL1: 5–100 mA (005–100) • AGL2: 80–950 mA (080–950) TR3 “Tri-set” models (field jumper select): <ul style="list-style-type: none"> • AG3: 5, 10, or 30 mA
Output	Electromechanical SPDT relay
Output Rating	1 A @ 125 VAC, 2 A @ 30 VDC
LED Display	<ul style="list-style-type: none"> • Green LED = Power On indication • Red LED = Tripped Output Relay indication
Response Time	<ul style="list-style-type: none"> • 200 ms @ 5% above trip point • 60 ms @ 50% above trip point • 15 ms @ 500% above trip point
Time Delay	None
Noise Immunity	<ul style="list-style-type: none"> • EMI/RFI Shielding • Power supply noise filtering
Isolation Voltage	UL listed to 1270 VAC, tested to 5 KV
Frequency Range	50–60 Hz (monitored circuit)
Case	UL94 V-0 Flammability Rated
Mounting	DIN rail mounting
Environmental	-4 to 122°F (-20 to 50°C) 0–95% RH, non-condensing
Listings	UL/cUL, CE

Ground Fault Protection Ordering Information

Sample Model Number: AGL1-NOR-120-LA-005
 Ground fault relay with normally open SPST latching relay output, 120 VAC power supply and 5 mA trip point.

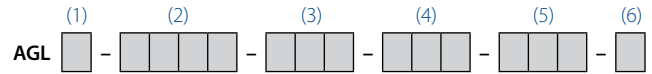

(1) Setpoint Range

1	5–100 mA factory set
2	80–950 mA factory set
3	5/10/30 mA jumper set

(2) Output Type

NCR1	Normally Closed SPST Relay Form B (Available only with -LA option)
NOR1	Normally Open SPST Relay Form A (Available only with -LA option)
SDT1	SPDT Relay (Form C) with auto-reset (Available only with -DEN and -ENE options)

(3) Power Supply

120	120 VAC
24U	24 VAC/DC

(4) Options

ENE	Normally energized, auto-reset (SDT1 output only)
DEN	Normally de-energized, auto-reset (SDT1 output only)
LA	Latching (NOR1 and NCR1)

(5) Setpoint

TR3	Tri-set
005 to 950	Factory set trip point in mA

(6) Noise Immunity

N	Noise immunity
	None (blank)

Output Tables

Normally Energized Models (-ENE Option)

Protection from faults and control power loss.

	Control Power Applied		
	No Power	No Fault	Fault
N.C. Normally Closed	closed	open	closed
N.O. Normally Open	open	closed	open

Normally De-energized Models (-DEN Options)

Protection from faults only when power is applied.

	Control Power Applied		
	No Power	No Fault	Fault
N.C. Normally Closed	closed	closed	open
N.O. Normally Open	open	open	closed

AGLD SERIES

Ground Fault Relay with Digital Display

AGLD Series Ground Fault Sensors keep machinery and their operators safe from accidental shocks. The large, one piece solid-core design allows for installation over wires feeding heavy loads. The output relay will change state at any point between 5 and 100 mA, or 80 and 950 mA. A delay can be set to allow down stream protection to activate before this sensor, keeping the main circuit protection hot and the equipment energized while the smaller faults are cleared. The large LED display shows the precise trip point and the extra delay clearly, in any light condition. The display flashes when there is current sensed over the trip point.

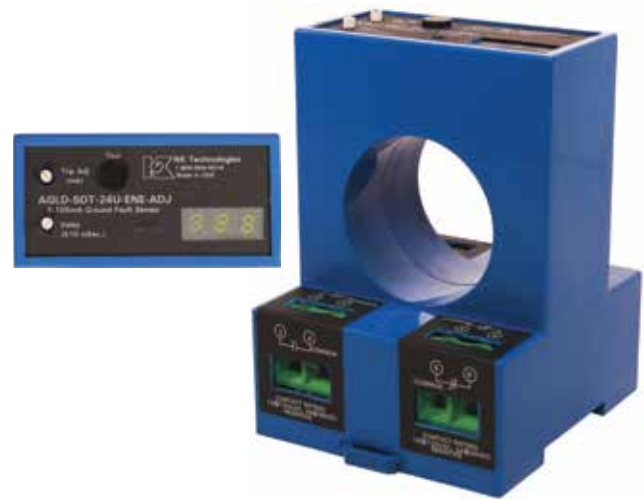

Ground Fault Relay Applications

Monitor Large Machines

- Detect fault currents before damage can occur. Connect the output to a shunt trip breaker operating solenoid or to the circuit powering a connector coil.

Water Delivery and Treatment

- Detect moisture ingress in submersible pumps.

Heating Processes

- If an element shorts to ground, the sensor will activate to de-energize the circuit, keeping safety at the forefront.

Insulation Breakdown

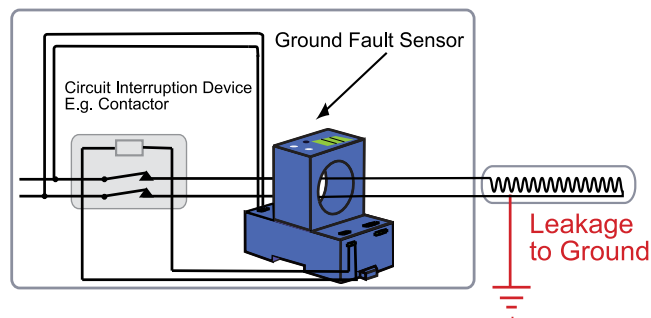

Ground Fault Relay Features

Electromechanical Relay Output

- Provides both normally open and normally closed contacts.
- Compatible with most automation and control systems.

Externally Powered

- A choice of fail safe or standard operation.

Simple Field Setpoint Adjustment

- Single turn potentiometer with setpoint shown on display.
- Adjustable delay shown when knob is turned.

Large Solid-core Case

- Large sensing window provides ample space for multiple conductors.

DIN Rail Mount*

- Simple snap onto DIN rail.

UL/cUL and CE Approved

- UL/cUL and CE Approved
- Accepted worldwide.

*For information on the DIN rail accessories kit, see page 128.

OEMs

Test & Evaluation Units for OEMs

Free program expedites evaluation process. See page 3 for details.



Ground Fault Protection Dimensions

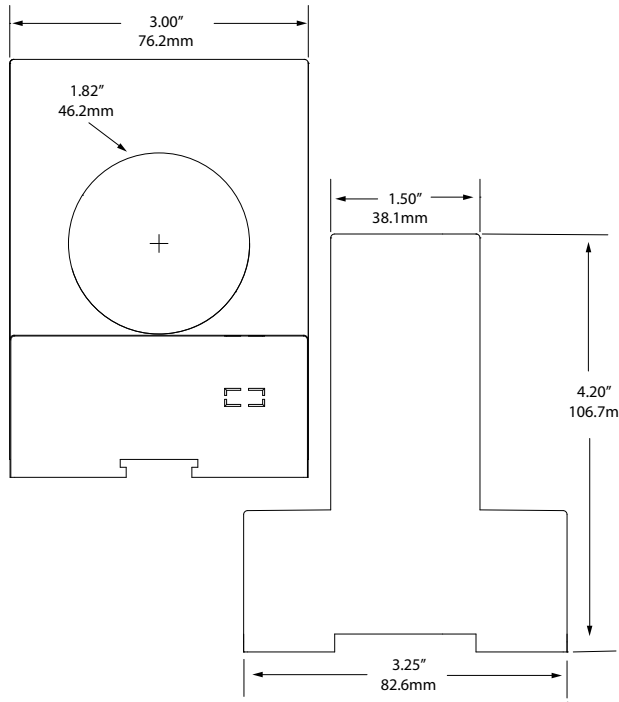

Ground Fault Protection

Ground Fault Protection Specifications



Power Supply	• 120 VAC (108–132 V) • 24 VAC/DC (22–36 V)
Power Consumption	<4 VA
Setpoint Range	AGLD1: 5–100 mA AGLD2: 80–950 mA
Output	Electromechanical SPDT relay
Output Rating	1 A @ 120 VAC, 2 A @ 30 VDC max.
LED Display	• Displays trip point in mA • Displays delay period when adjusted (ms X10) • Off: Power off
Response Time	120 ms
Output Operation	Normally energized or normally de-energized
Time Delay	10 sec. (adjustable after startup)
Isolation Voltage	Tested to 5 KV
Frequency Range	50–60 Hz (monitored circuit)
Case	UL94 V-0 Flammability Rated
Mounting	DIN rail mounting
Environmental	-4 to 122°F (-20 to 50°C) 0–95% RH, non-condensing
Listings	UL/cUL Listed, CE

Ground Fault Protection Connections

Auto Reset

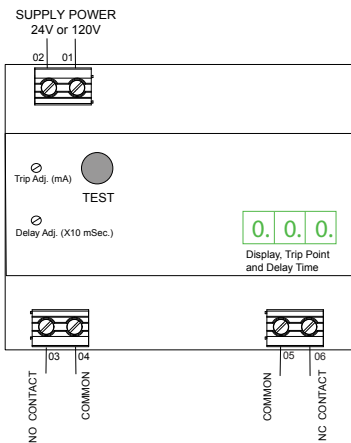

Latching

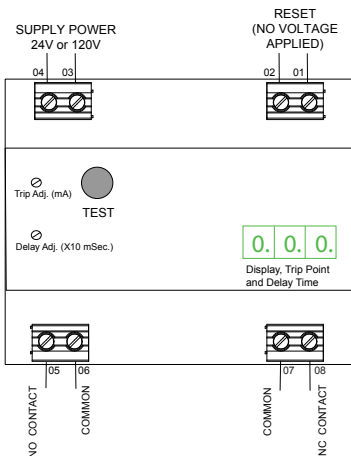

Ground Fault Protection Ordering Information

Sample Model Number: AGLD1-SDT1-24U-ENE-ADJ
AC ground fault sensor, 5–100 mA range, SPDT relay output, 24 VAC/DC powered, large case, DIN rail mounting.

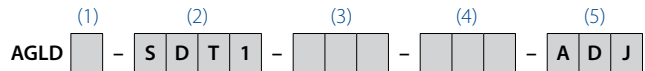

(1) Model	
1	5–100 mA
2	80–950 mA
(2) Output Type	
SDT1	Single pole, double throw relay
(3) Power Supply	
24U	24 VAC/DC
120	120 VAC
(4) Contact Action	
DEN	Normally de-energized
ENE	Normally energized
LA	Latching output
(5) Setpoint	
ADJ	Adjustable setpoint

AGT SERIES

Ground Fault Indicators

AGT Series Ground Fault Indicators combine a current transformer and a True RMS signal conditioner into a single package. The AGT Series is designed to produce an analog 4–20 mA signal proportional to earth or ground fault current, or any low consumption AC load. Available in a solid-core case. When connected to a controller or data logger, NEC requirements for alarm can be met.



Ground Fault Protection Applications

Current Leakage Detection

- Monitor heating or other loads to detect increasing leakage current.
- Pass all current carrying conductors through aperture to sense zero-sum current.

Very Light Loads

- Accurate measurement of very small but critical loads.
- Current measurement gives faster response than temperature measurement.

Ground Fault Currents

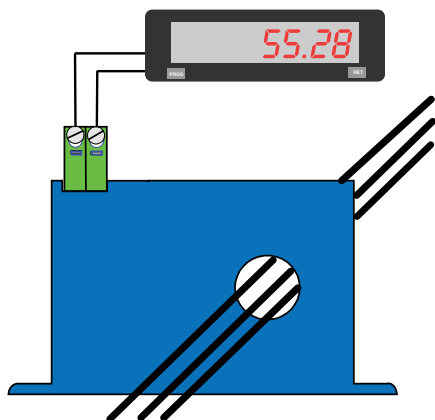

- For additional Application Examples, go to www.nktechnologies.com/applications

Ground Fault Protection Features

True RMS Output

- True RMS technology is accurate on distorted waveforms like VFD or SCR outputs.

Single Range

- No chance of field range selection errors.
- Eliminates zero and span pots.

Isolation

- Output is magnetically isolated from the input for safety.
- Eliminates insertion loss (voltage drop).

UL/cUL Approved

- Accepted worldwide.

Selecting the right ground fault detector:

NEC Article 427-22 requires that fault currents be monitored on industrial equipment. However, where maintenance and supervision ensure that only qualified persons will service the equipment and continued circuit operation is necessary for safe operation and processes, alarm indication is also required. A fault current transducer can send a signal to a panel meter with alarm contacts or a controller. As an example, the alarm points can be configured so one alarm is initiated when fault current reaches 30 mA, and another when it rises above 70 mA. Ground fault protection is required in many applications, and NK Technologies has a sensor that can be coupled with your control system to provide this needed alarm or circuit disconnection.

Ground Fault Protection

OEMs

Test & Evaluation Units for OEMs

Free program expedites evaluation process. See page 3 for details.



Ground Fault Protection Dimensions

FL Case

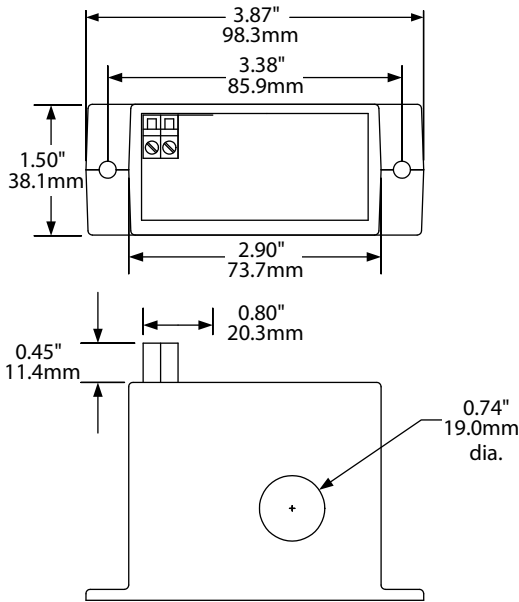

Ground Fault Protection

Ground Fault Protection Connections

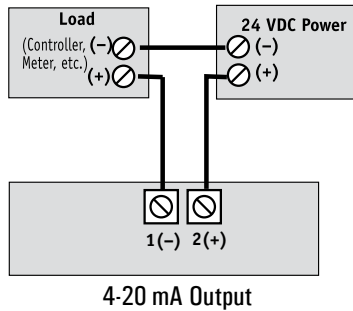

Notes:
 Finger safe captive screw terminals.
 12–22 AWG solid or stranded.
 Observe polarity.

Ground Fault Protection Specifications



Power Supply	24 VDC loop-powered (12–40 V)
Power Consumption	<2 VA
Output	4–20 mA, loop-powered, True RMS
Output Limit	23 mA
Response Time	600 ms (to 90% step change)
Input Range	Single range of 0–50 or 0–100 mA; custom ranges available; consult factory.
Isolation Voltage	UL listed to 1270 VAC, tested to 5 KV
Frequency Range	40–400 Hz
Case	UL94 V-0 Flammability Rated
Environmental	-4 to 122°F (-20 to 50°C) 0–95% RH, non-condensing
Listings	UL/cUL

Ground Fault Protection Ordering Information

Sample Model Number: AGT2-420-24L-FL
 True RMS AC ground fault indicator, 100 mA ranges, 4–20 mA output, 24 VDC loop-powered in a solid-core case.



(1) Full Scale Range	
1	0–50 mA
2	0–100 mA
(2) Output Signal	
420	4–20 mA
(3) Power Supply	
24L	24 VDC loop-powered (4–20 mA output ONLY)
(4) Case Style	
FL	Solid-core, top term.

DG SERIES

DC Ground Fault Relay

DG Series Ground Fault Sensors keep machinery and their operators safe from accidental shocks. The one-piece, solid-core design allows for installation over wires feeding loads to about fifty amps. The output relay will change state at factory setpoint between 5 and 50 mA of DC current to earth.



Ground Fault Relay Applications

Monitor Photovoltaic Panels

- Detect fault currents before damage can occur. Connect the output to a shunt trip breaker operating solenoid or to the circuit powering a contactor coil.

Water Delivery and Treatment

- Detect moisture ingress in submersible pumps .

Heating Processes

- If an element shorts to ground, the sensor will activate to de-energize the circuit, keeping safety at the forefront.

Communications Towers

- Notification if a battery powered supply is allowing current to earth.

Ground Fault Relay Features

Electromechanical Relay Output

- Auto reset models have both normally open and normally closed contacts.
- Latching models have one normally open and one normally closed contact.
- Compatible with most automation and control systems.

Externally Powered

- A choice of fail safe or standard auto reset operation, or latching contact.

Solid-Core Case

- Sensing window provides ample space for multiple conductors.

Designed for UL, CUL and CE Approval

- Accepted worldwide.

DC Fault Current Sensing

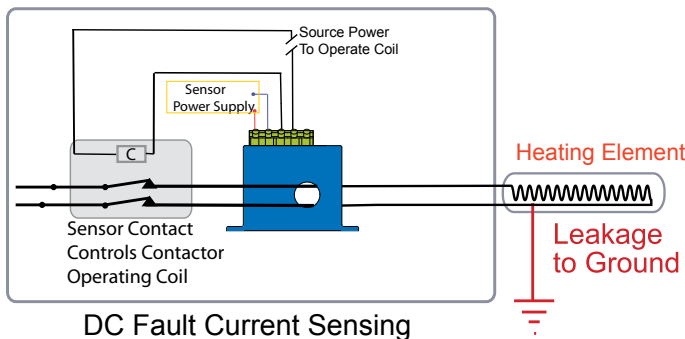

OEMs Test & Evaluation Units for OEMs
Free program expedites evaluation process. See page 3 for details.



Ground Fault Relay Dimensions

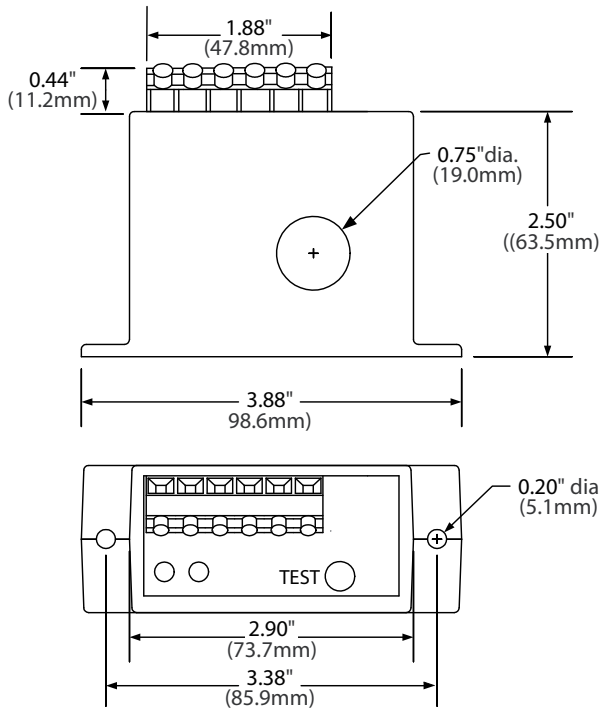

Ground Fault Relay Specifications

Power Supply	24 VDC (20–26 V)
Power Consumption	<4VA
Output	Electromechanical relay 1 A @ 120 VAC, 2 A @ 30V DC Max.
Output Operation	Normally Energized Normally De-energized Latching
Output Range	5–50 mA
Response Time	55 ms maximum
Input Range	Up to 1500 VDC (monitored circuit)
Isolation Voltage	tested to 5000 V
Frequency Range	DC
Case	UL94 V-0 Flammability Rated
Environmental	-4 to 122°F (-20 to 50°C) 0–95% RH, non-condensing
Listings	Designed to meet UL 508 Industrial Control Equipment (USA & Canada)

Ground Fault Protection

Ground Fault Relay Connections

Auto Reset Connection

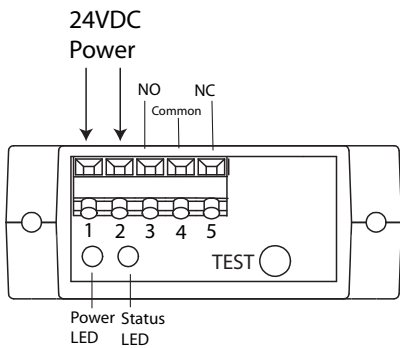

Latching Connection

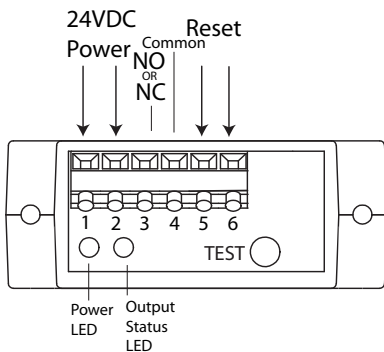

Ordering Information

Sample Model Number: DG1-SDT-24D-ENE-010 DC ground fault sensor, output 5–50 mA SPDT relay output, 24 VDC powered, normally energized, 010 factory set trip point.



(1) Range

1	5–50 mA
---	---------

(2) Output Type

SDT	Single pole, double throw relay (Auto Reset Only)
NCR	Normally Closed, latching model only
NOR	Normally Open, latching model only

(3) Power Supply

24D	24 VDC
-----	--------

(4) Contact Action

DEN	Normally de-energized output
ENE	Normally energized output
LA	Latching output

(5) Trip Point

005–050	Factory set trip point
---------	------------------------

Voltage Transducers

NK Technologies' voltage transducers are high-performance transducers for sensing voltage in installations. They are available in an AC or DC Series and come in a variety of nominal voltages.

Features:

- AC or DC models
- Standard 4–20 mA powered output
Industry standard output makes use with existing controllers, data loggers and SCADA equipment easy and reliable
- Input/Output Isolation
Input and output circuitry electrically isolated for improved safety of use
- Compact DIN rail mount case
Transducer housing mounts to standard DIN rail or to a flat panel

- **VTR SERIES**
AC Voltage Transducers page 94
- **VTD SERIES**
DC Voltage Transducers..... page 96
- **VTD-BD SERIES**
DC Voltage Transducers..... page 98
- **VTU SERIES**
High Voltage DC/AC Voltage Transducerspage 100
- **VTU-DIN SERIES**
AC or DC Voltage Transducers.....page 102

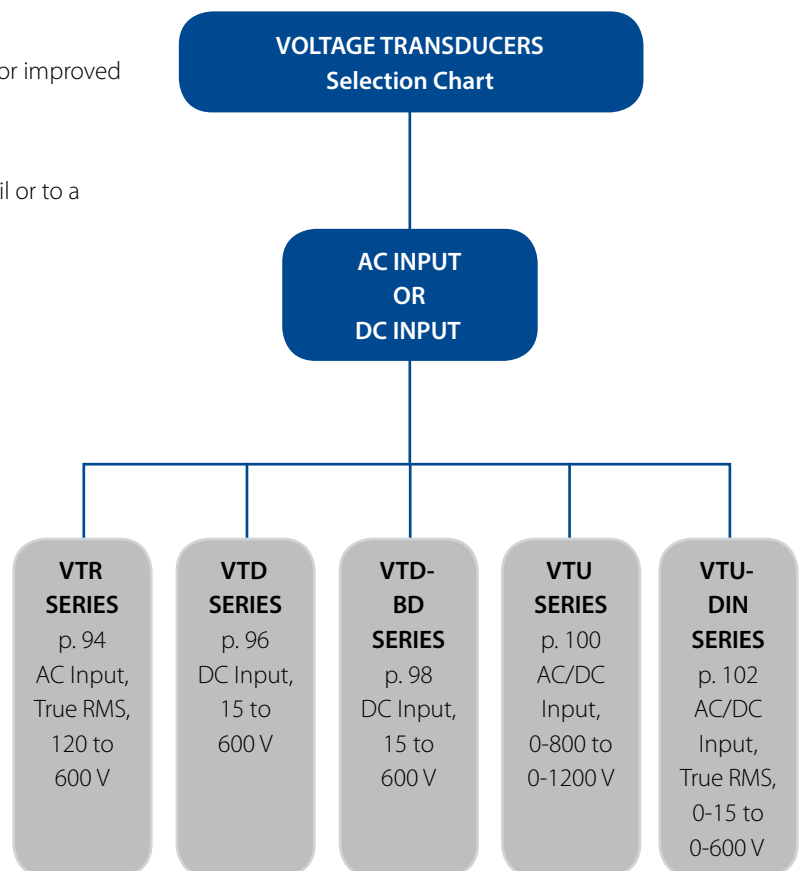

VTR SERIES

AC Voltage Transducers

VTR Series AC Voltage Transducers are high-performance True RMS transducers for sensing voltage in single- and three-phase installations. Applicable on circuits of 120 V, 240 V, 480 V and 600 V, the VTR Series voltage transducers provide a fully isolated, 4–20 mA output proportional to rated voltage in sinusoidal situations. Housed in a slim, compact, easy-to-install DIN rail mounted case, the VTR Series comes in a variety of voltage ranges and with four-wire terminal block connection.



Voltage Transducer Applications

True RMS Voltage Monitoring

- Detect below normal or “brown out” voltage conditions; protect against possible motor overheating.
- Identify phase loss conditions by detecting voltage reduction in one or more phase of three-phase motor.
- Monitor over voltage conditions associated with regenerative voltage to help in diagnosing/avoiding motor drive issues.
- Detect voltage conditions which may cause stress in or damage to soft starter components (SCRs).

Phase Loss Protection

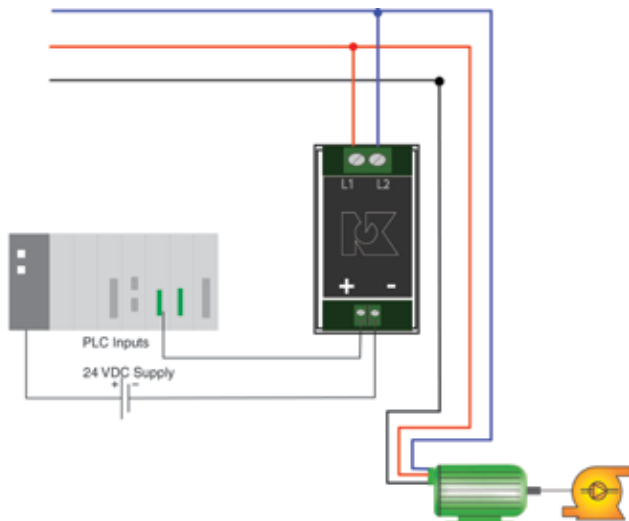

For additional Application Examples, go to www.nktechnologies.com/applications

Voltage Transducer Features

True RMS Output

- Allows for use in situations where power supplied is poor power quality or other electrically harsh/challenging environments.

Standard 4–20 mA Loop-powered Output

- Industry standard output makes use with existing controllers, data loggers and SCADA equipment easy and reliable.

Input/Output Isolation

- Input and output circuitry electrically isolated for improved safety of use.

Compact DIN Rail Mounted Case*

- Space saving 35 mm wide enclosure mounts quickly for an attractive installation.

UL/cUL and CE Approved

- Accepted worldwide.

*For information on the DIN rail accessories kit, see page 128.

Voltage Transducer Dimensions

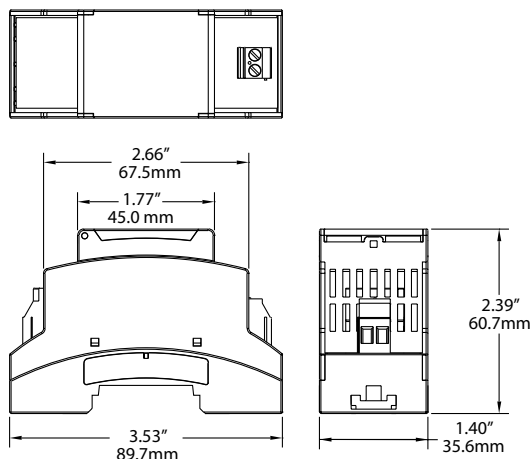

Voltage Transducer Connections

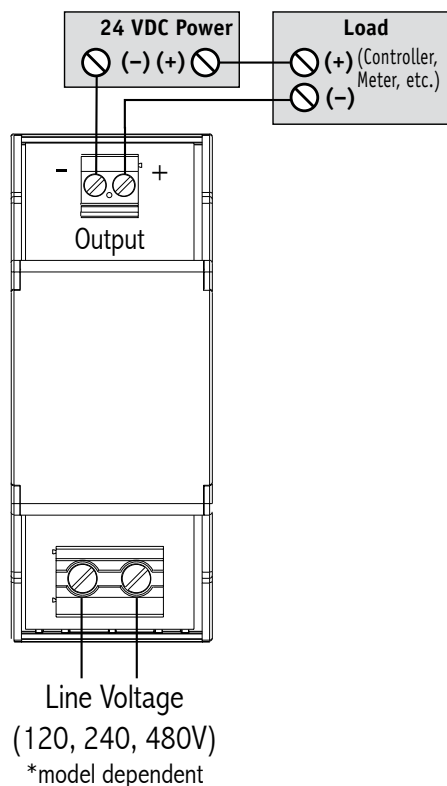

Voltage Transducer Specifications



Power Supply	24 VDC loop-powered (12–40 VDC)
Input Range	120 V, 150 V, 240 V, 480 V, 500 V, 600 V
Output	4–20 mA proportional
Output Limit	24 mA
Output Loading	500 Ω
Input Maximum	130% of range
Response Time	250 ms (to 90% value)
Accuracy	1.0% FS (10–100% of range) (1% at 60 Hz, 2.5% at 50 Hz)
Isolation Voltage	UL listed to 1270 VAC, tested to 5 KV
Frequency Range	40–100 Hz
Case	UL94 V-0 Flammability Rated
Mounting	DIN rail or panel mounting
Environmental	-4 to 122°F (-20 to 50°C) 0–95% RH, non-condensing
Listings	UL/cUL (except 600 V), CE

Voltage Transducer Ordering Information

Sample Model Number: VTR1-420-24L-DIN
True RMS voltage transducer with 120 V voltage range, standard 4–20 mA proportional output; 24 V loop-powered with a DIN rail compatible case.



(1) Voltage Range	
1	120 V
2	150 V
3	240 V
4	480 V
5	500 V
6	600 V

(2) Output Type	
420	4–20 mA

(3) Supply Voltage	
24L	24 V loop-powered

(4) Mounting	
DIN	DIN rail compatible

OEMs

Test & Evaluation Units for OEMs

Free program expedites evaluation process. See page 3 for details.



VTD SERIES

DC Voltage Transducers

VTD Series Voltage Transducers are high-performance transducers for sensing voltage in DC powered installations. Applicable for use on circuits to 600 VDC, VTD voltage transducers provide fully isolated 0–5 VDC, 0–10 VDC, and 4–20 mA outputs proportional to rated nominal voltage in DC circuits. Housed in a slim, compact, easy-to-install DIN rail mounted case, the VTD Series comes in a variety of nominal voltages.



Voltage Transducer Applications

Voltage Monitoring

- Detect below normal or “brown out” voltage conditions; protect against possible motor overheating.
- Identify conductor loss conditions by detecting voltage reduction in one motor lead.
- Monitor over voltage conditions associated with regenerative voltage to help in diagnosing/avoiding motor drive issues.
- Detect voltage conditions that may cause stress or damage to soft starter components (SCRs).

DC Voltage Transducer Control

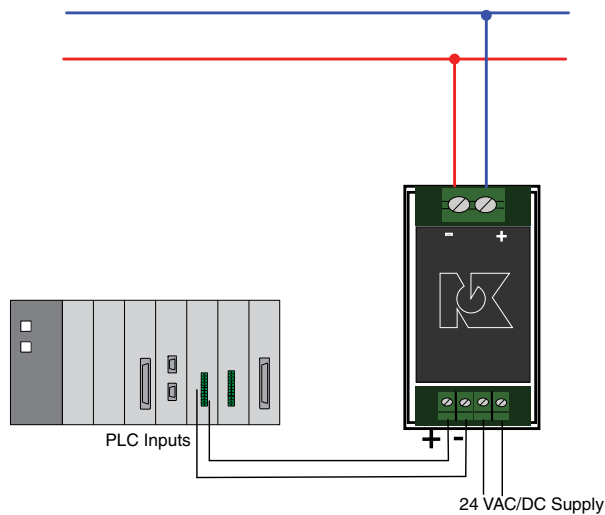

For additional Application Examples, go to www.nktechnologies.com/applications

Voltage Transducer Features

Accurate Output

- Several ranges available for your application, from 0–15 VDC to 0–600 VDC.

Standard Current and Voltage Sensor Outputs

- Industry standard outputs makes use with existing controllers, data loggers and SCADA equipment easy and reliable.

Input/Output Isolation

- Input and Output circuitry electrically isolated for improved safety of use.

Compact DIN Rail Mounted Case*

- Space saving 35 mm wide enclosure mounts quickly for an attractive installation.

UL/cUL and CE Approved

- Accepted worldwide.

*For information on the DIN rail accessories kit, see page 128.

Voltage Transducer Dimensions

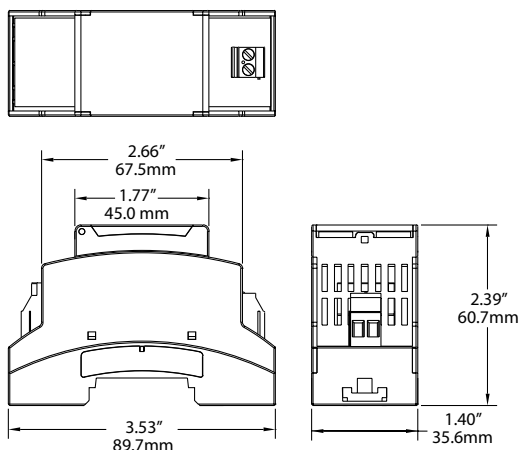

Voltage Transducer Connections

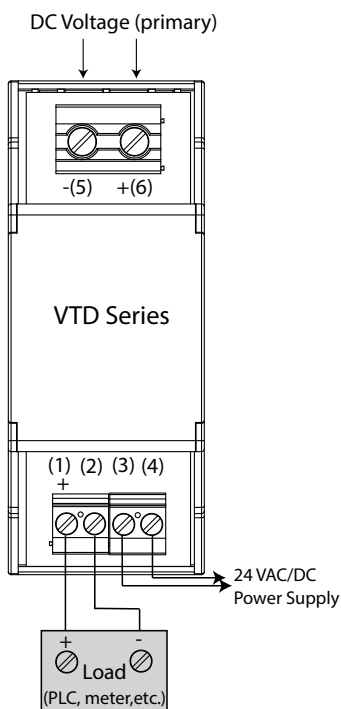

Voltage Transducer Specifications



Power Supply	24 VAC/DC (20–45 DC, 22–38 VAC)
Input Range	15 V, 25 V, 50 V, 150 V, 300 V, 600 VDC
Power Consumption	<2 VA
Output	<ul style="list-style-type: none"> • 4–20 mA (capped at 24 mA max.) • 0–5 VDC (capped at 5.75 VDC), • 0–10 VDC (capped at 11.5 VDC)
Output Loading	<ul style="list-style-type: none"> • 4–20 mA output: <500 Ω • 0–5/10 VDC output: >10 KΩ
Response Time	250 ms (90% step change)
Accuracy	<1%
Isolation Voltage	UL listed to 1270 VAC, tested to 5 KV
Frequency Range	DC
Case	UL94 V-0 Flammability Rated
Mounting	DIN rail or panel mounting
EMC/Immunity	EN50081-1, EN50082-2
Ripple	<1% (peak to peak)
Environmental	-4 to 122°F (-20 to 50°C) 0–95% RH, non-condensing
Listings	UL/cUL, CE

Voltage Transducer Ordering Information

Sample Model Number: VTD1-420-24U-DIN
 DC voltage transducer with 25 V range, standard 4–20 mA proportional output; 24 V externally powered with a DIN rail compatible case.



(1) Nominal Range

0	0–15 VDC
1	0–25 VDC
2	0–50 VDC
3	0–150 VDC
4	0–300 VDC
5	0–600 VDC

(2) Output Type

005	0–5 VDC
010	0–10 VDC
420	4–20 mA

(3) Supply Voltage

24U	24 VAC/DC external power supply
-----	---------------------------------

(4) Mounting

DIN	DIN rail compatible
-----	---------------------



Test & Evaluation Units for OEMs

Free program expedites evaluation process. See page 3 for details.



Voltage Transducers

VTD-BD SERIES

DC Voltage Transducers

VTD-BD Series Voltage Transducers are high-performance transducers for sensing voltage in DC powered installations. Applicable for use on circuits to 600 VDC, VTD-BD voltage transducers provide a fully isolated +/- 5 VDC or +/- 10 VDC output signal in response to DC voltages that change polarity. Housed in an easy-to-install DIN rail or panel mount case, the VTD-BD Series comes in a variety of ranges to suit many primary voltages.



Voltage Transducer Applications

Voltage Monitoring

- Detect below normal or “brown out” voltage conditions; protect against possible motor overheating.
- Identify conductor loss conditions by detecting voltage reduction in one motor lead.
- Monitor over voltage conditions associated with regenerative voltage to help in diagnosing/avoiding motor drive issues.
- Detect voltage conditions that may cause stress in or damage to soft starter components (SCRs).

DC Voltage Transducer

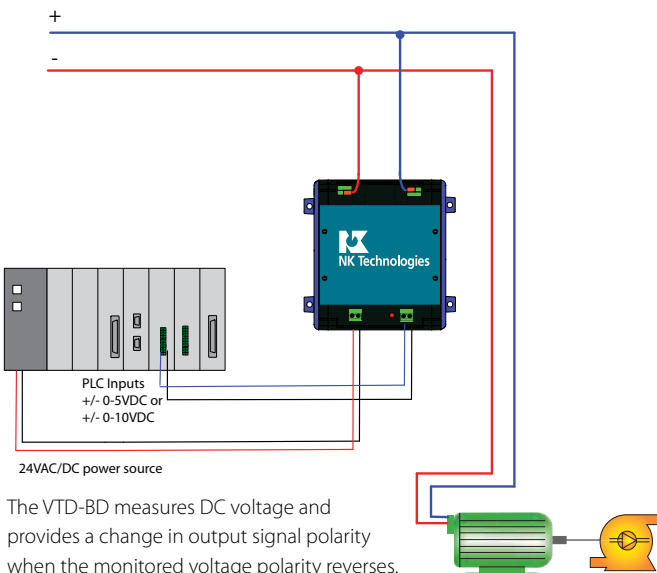

The VTD-BD measures DC voltage and provides a change in output signal polarity when the monitored voltage polarity reverses. Positive on upper right terminal creates a positive output signal; positive on upper left terminal creates a negative output signal.

Voltage Transducer Features

Wide Input Range Selection

- Six ranges of input voltages to best fit your requirements, from +/- 0–15 VDC to +/- 0–600 VDC.

+/- 5 VDC or +/- 10 VDC Sensor Powered Outputs

- Industry standard outputs makes use with existing controllers, data loggers and SCADA equipment easy and reliable.

Input/Output Isolation

- Input and output circuitry electrically isolated for improved safety of use.

DIN Rail or Panel Mount Case*

- Enclosure mounts quickly for an attractive installation.

*For information on the DIN rail accessories kit, see page 128.

For additional Application Examples, go to www.nktechnologies.com/applications

Voltage Transducer Dimensions

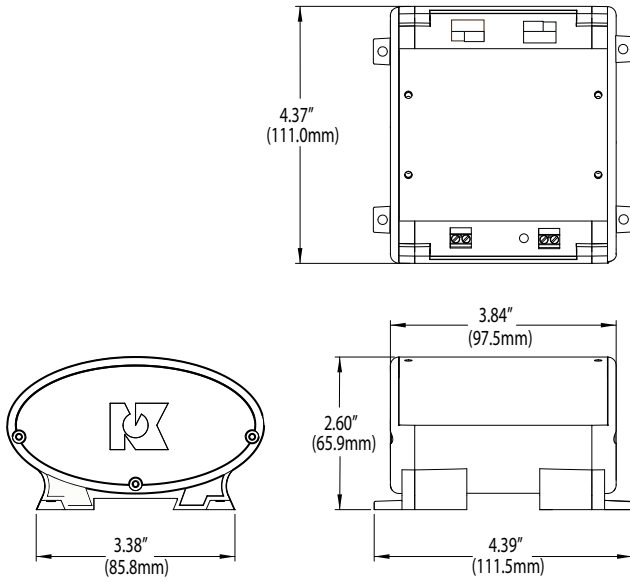

Voltage Transducer Specifications

Power Supply	24 VAC/DC (22–26V)
Input Range (+/-)	15 V, 25 V, 50 V, 150 V, 300 V, 600 VDC
Input Impedance	>160K Ω
Power Consumption	<2VA
Output	• +/-5 VDC • +/-10 VDC
Output Impedance	>10K Ω
Response Time	500 ms (10–90% step change)
Accuracy	1.0% of FS
Isolation Voltage	2500 V
Frequency Range	DC
Mounting	DIN rail or panel mounting
Case	UL94 V-0 Flammability Rated
Environmental	-4 to 122°F (-20 to 50°C) 0–95% RH, non-condensing
Listings	Designed to meet UL, cUL and CE

Voltage Transducer Connections

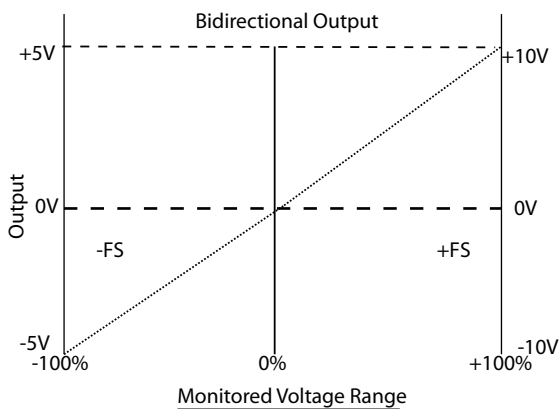
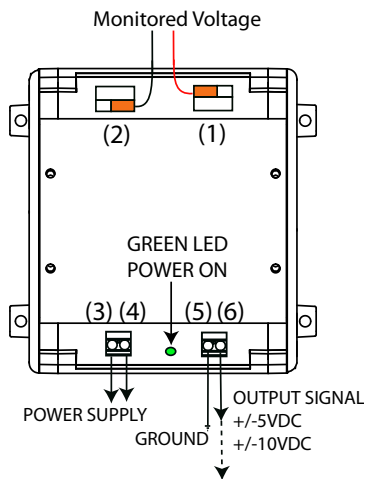

Voltage Transducer Ordering Information

Sample Model Number: VTD0-010-24U-BD-OS
DC voltage transducer with 15 V range, +/-10 VDC proportional output; 24 V externally powered, bidirectional output with a DIN rail compatible case.

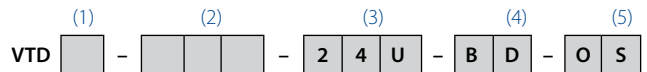

(1) Nominal Range

0	+/-15 V
1	+/-25 V
2	+/-50 V
3	+/-150 V
4	+/-300 V
5	+/-600 V

(2) Output Signal

005	+/-5 VDC
010	+/-10 VDC

(3) Supply Voltage

24U	24 VAC/DC external power supply
-----	---------------------------------

(4) Output Type

BD	Bidirectional output
----	----------------------

(5) Mounting

OS	DIN rail or panel mounting
----	----------------------------

Voltage Transducers

OEMs Test & Evaluation Units for OEMs
Free program expedites evaluation process. See page 3 for details.



VTU SERIES

High Voltage DC/AC Voltage Transducer

VTU Series Voltage Transducers provide very high accuracy and safety in a panel or DIN rail mounted case. The one sensor design can measure DC or AC circuit voltages to 1200 volts, and produce an analog signal directly proportional to the voltage connected. A very valuable tool to spot issues with power generation (conventional and alternative sources) like brownouts and phase loss. The voltage will be present on the line side of a disconnect even when the breaker or switch is open.



Voltage Transducer Applications

Photovoltaic Panels

- Connecting panel outputs in series increases the voltage sent from the panels to the load up to 1200 volts DC. The VTU is designed to measure this safely.

Water Delivery and Treatment

- Measure the AC voltage to pumps and aerators and shut them down if the supplied voltage falls to a dangerous level.

Cranes and Lifting Apparatus

- DC motors are used to lift, place and position heavy objects, as they have full torque capacity at zero speed. Use a voltage transducer to be sure that the field windings have voltage to keep the motor speed under control.

Voltage Transducer Features

Industry Standard Output Options

- 4–20 mA, 0–5 and 0–10 VDC.
- Compatible with most automation and control systems.
- Output proportional to RMS voltage.

Externally Powered

- 24 VAC or DC with low power consumption.

Simple Conductor Termination

- Primary circuit uses self-tightening terminals.
- Power supply and output terminals are finger-safe.

Panel or DIN Rail Mounting Options*

- If a DIN rail is not available, use the screw mounting option to attach to a back panel.
- Power supply is isolated from input and output.

UL/cUL Approved, CE Approval Pending

- Accepted worldwide.

*For information on the DIN rail accessories kit, see page 128.

VTU Measures Both AC and DC Voltages

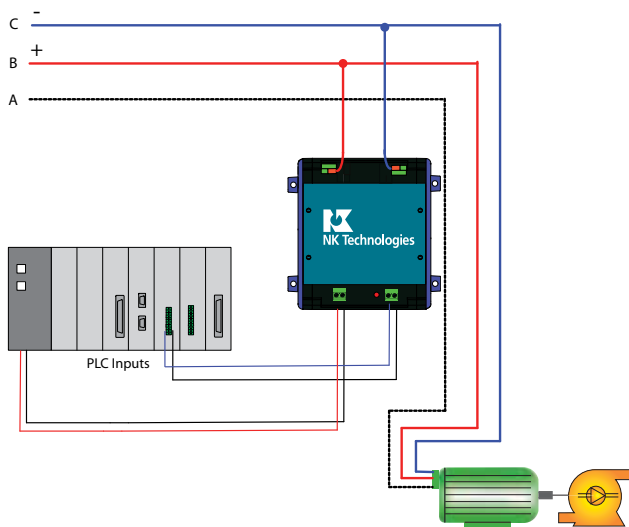



Voltage Transducer Dimensions

OS Case

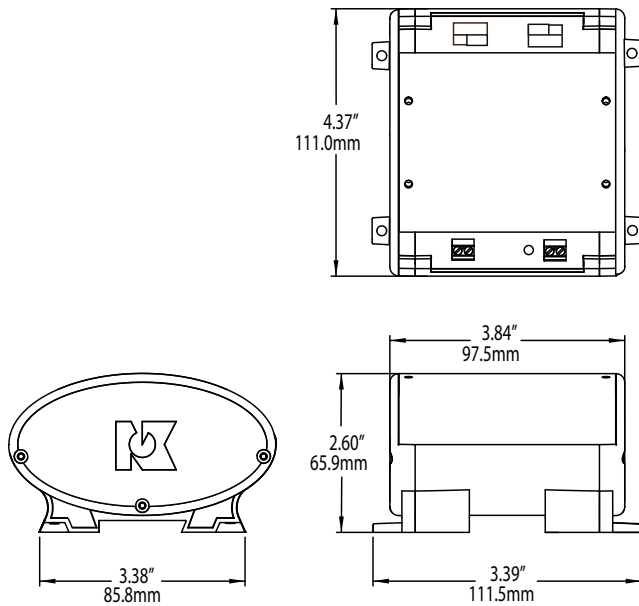

Voltage Transducer Specifications

Power Supply	24 VAC/DC (22–26 VAC or DC)
Input Range	0–800, 1000 or 1200 VAC or DC
Power Consumption	< 2VA
Output	<ul style="list-style-type: none"> • 4–20 mA • 0–5 VDC • 0–10 VDC
Output Loading	<ul style="list-style-type: none"> • 4–20 mA: <400 Ω • 0–5/10 VDC: >100 KΩ
Response Time	100 ms
Accuracy	<1% FS
Isolation Voltage	UL listed to 1270 VAC, tested to 5 KV
Frequency Range	0–400 Hz
Case	UL94 V-0 Flammability Rated
Mounting	DIN rail or panel mounting
Listings	UL/cUL, CE pending

Voltage Transducer Ordering Information

Sample Model Number: VTU10-420-24U-OS
 AC or DC voltage transducer, 0-1000 V primary, 4-20 mA secondary, 24 VAC/DC power, DIN or panel mounting enclosure.



(1) Range

8	0–800 V
10	0–1000 V
12	0–1200 V

(2) Output Type

005	0–5 VDC
010	0–10 VDC
420	4–20 mA

(3) Supply Voltage

24U	24 VAC/DC external power supply
-----	---------------------------------

(4) Case Style

OS	DIN rail or panel mounting case
----	---------------------------------

Voltage Transducer Connections

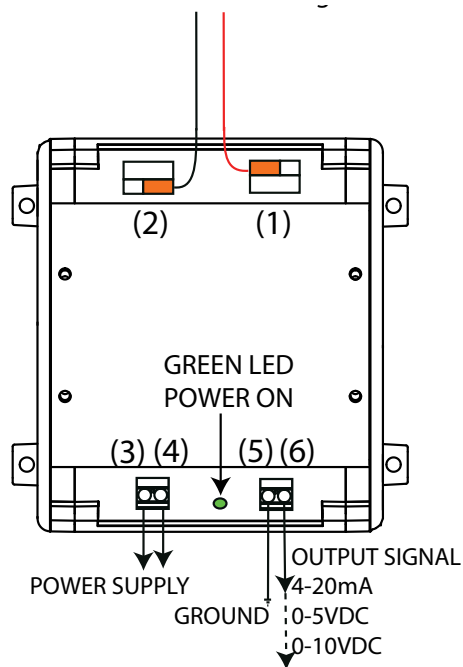

OEMs

Test & Evaluation Units for OEMs

Free program expedites evaluation process. See page 3 for details.



VTU-DIN SERIES

AC or DC Voltage Transducers

VTU-DIN Series Voltage Transducers are high-performance True RMS transducers for sensing voltage in single, three-phase or DC installations. Housed in a slim, compact, easy-to-install DIN rail mounting enclosure, these transducers come in a variety of voltage ranges. The VTU-DIN measures AC or DC voltage from 0–15 to 0–600 V and provides an industry standard output proportional to connected voltage in alternating current circuits with sinusoidal or non-sinusoidal (variable frequency) applications or direct current circuits.



Voltage Transducer Applications

True RMS or DC Voltage Monitoring

- Detect below normal or “brownout” voltage conditions; protect against possible motor overheating.
- Identify phase loss conditions by detecting voltage reduction in one or more phase of three-phase motor.
- Monitor over voltage conditions associated with regenerative voltage to help in diagnosing/avoiding motor drive issues.
- Detect voltage conditions that may cause stress or damage to soft starter components (SCRs).

Phase Loss Detection

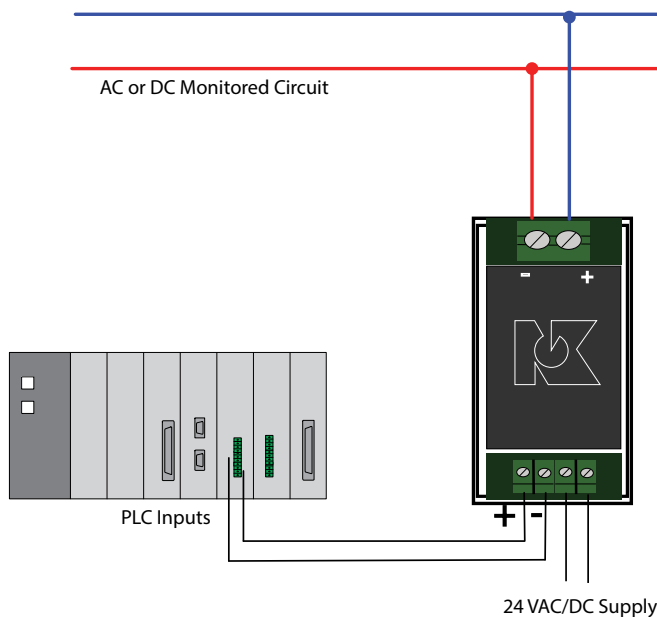

Voltage Transducer Features

Zero to 5 KHz Measurement

- Allows for use in situations where power supplied is non-sinusoidal such as VFD applications, poor power quality installations or other electrically harsh/challenging environments.

Standard Outputs

- Industry standard outputs makes use with existing controllers, data loggers and SCADA equipment easy and reliable.

Compact DIN Rail Mount Case*

- Space saving 35 mm wide enclosure mounts quickly for an attractive installation.

UL/cUL Listed and CE Approval

- Accepted worldwide.

*For information on the DIN rail accessories kit, see page 128.

Voltage Transducer Dimensions

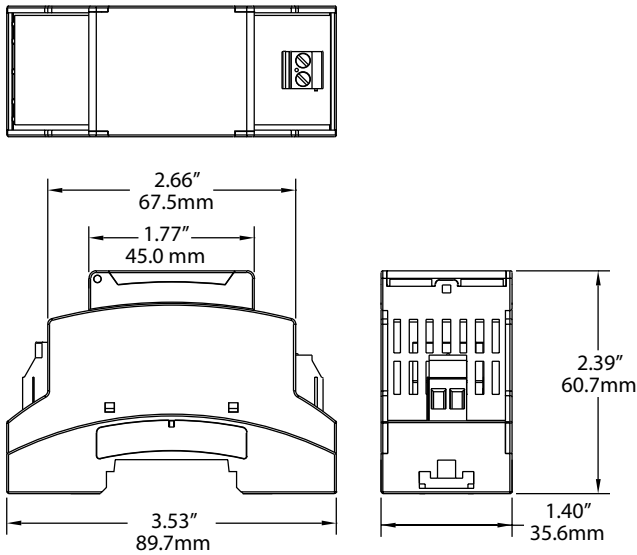

Voltage Transducer Specifications



Power Supply	24 VAC or DC external power (Not isolated from the output)
Power Consumption	<2 VA
Input	0–15, 25, 50, 60, 120, 150, 240, 300, 400, 500, 600 V, AC or DC
Output	<ul style="list-style-type: none"> • 4–20 mA proportional (capped at 31 mA max.) • 0–5 VDC • 0–10 VDC
Response Time	500 ms (to 90% value)
Accuracy	<1% error
Loading	<ul style="list-style-type: none"> • 4–20 mA output: <400 Ω • 0–5/10 VDC output: >50 KΩ
Isolation Voltage	2500 VAC
Frequency Range	0 Hz–5 KHz
Mounting	DIN rail compatible
Case	UL94 V-0 Flammability Rated; noncorrosive thermoplastic
Environmental	-4 to 122°F (-20 to 50°C) 0–95% RH, non-condensing
Listings	UL/cUL Listed, CE approved

Voltage Transducer Connections

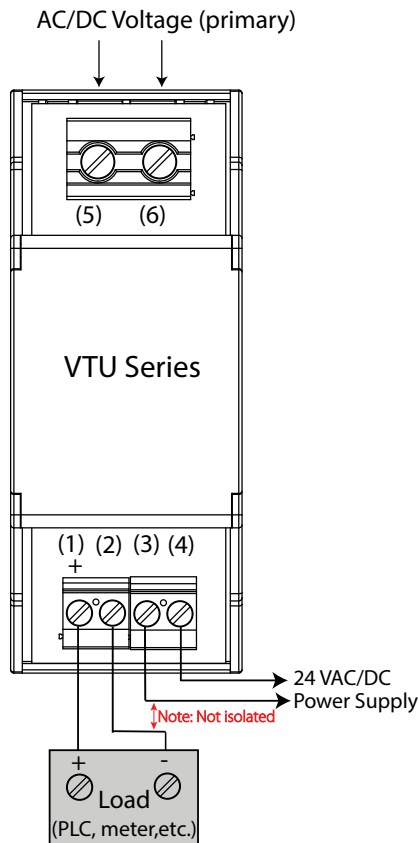

Voltage Transducer Ordering Information

Sample Model Number: VTUE-420-24U-DIN
AC/DC voltage transducer with 120 V range, standard 4–20 mA proportional output; 24 VAC/DC externally powered with a DIN-compatible case.



(1) Range

A	0–15 V
B	0–25 V
C	0–50 V
D	0–60 V
E	0–120 V
F	0–150 V
G	0–240 V
H	0–300 V
I	0–400 V
J	0–500 V
K	0–600 V

(2) Output Type

420	4–20 mA
005	0–5 VDC
010	0–10 VDC

(3) Power Supply

24U	24 VAC/DC external power supply
-----	---------------------------------

(4) Mounting

DIN	DIN rail compatible
-----	---------------------

OEMs Test & Evaluation Units for OEMs
Free program expedites evaluation process. See page 3 for details.



Power Sensing Products

Our power monitoring sensors measure loads and improve performance by providing instantaneous True Power kW or accumulated kWh data. They are simple, reliable and accurate. Digital communications are available in some models. Contact the factory or a local distributor for more information.

Features:

- 4–20 mA, 0–10 VDC, and/or networked outputs
- Accepts standard 5 A or 0–333 mV CT inputs
- DIN rail compatibility

- **APN SERIES**
Power Monitor.....page 105
- **APN-R SERIES**
Power Monitor.....page 107
- **APS SERIES**
Power Transducers.....page 109
- **APT SERIES**
Power Transducers.....page 111
- **APT-TH SERIES**
Power Transducers.....page 113

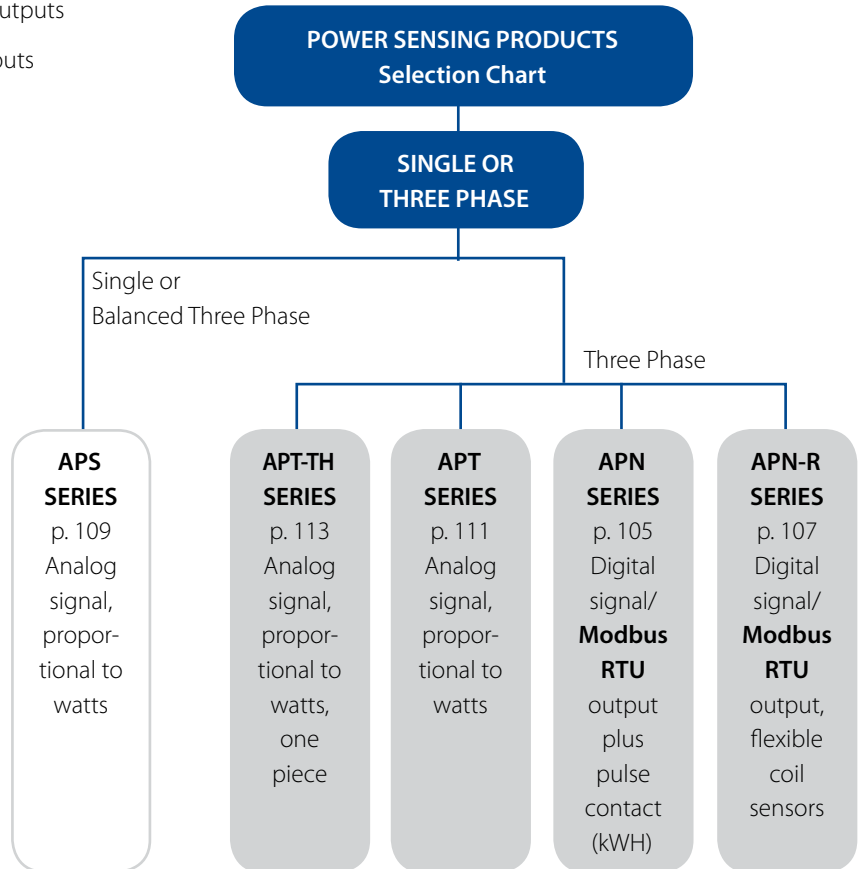

APN SERIES

Power Monitor

APN Series Power Monitors measure three phases of current and voltage and computes 14 values necessary to track power usage. The monitor uses current transformers to measure the amperes. The line voltage connects directly to the transducer, up to 600 VAC. The result is 14 data points in the RS485 **Modbus RTU** format. There is also a pulse contact which opens and closes as watt hours are accumulated. The APN can be configured to accept 5 A secondary current transformers or the safer ProteCT™ low voltage output CTs. Either type will produce an accurate set of data to help you save energy and avoid utility surcharges.



APN Power Monitor with **Modbus RTU** Output

Power Sensing Applications

Plant Energy Management

- Measure the power usage of a single piece of equipment, an area of a plant, or the entire facility.

Conveyors

- Detect jams and overloads.
- Check that the belt is loaded properly by measuring the power consumption.

Pump Monitoring

- Detect dry run from clogged, intake, or discharge line.
- Monitor impeller cavitation and bearing wear.

Pump Jam & Suction Loss Protection

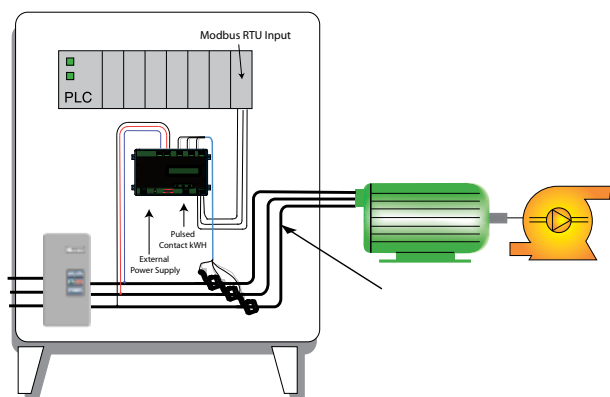

For additional Application Examples, go to www.nktechnologies.com/applications

Power Sensing Features

Modbus RTU Output

- RS485 communication protocol reduces the cost involved with proprietary data logging software.
- Compatible with most automation systems.

Externally Powered

- Improves reliability when used in conditions where power interruptions and voltage sags are common.

Compact DIN Rail Mounted Case*

- Clearly labeled terminals provide quick installation.
- Low profile reduces cabinet depth requirements.

LED Displays Network Communication

- Provides quick visual indication that network is operational.

Finger Safe Terminals

- Safe and secure connectors.

UL/cUL Approved

- Accepted worldwide.

*For information on the DIN rail accessories kit, see page 128.



Power Sensing Dimensions

Case Front View

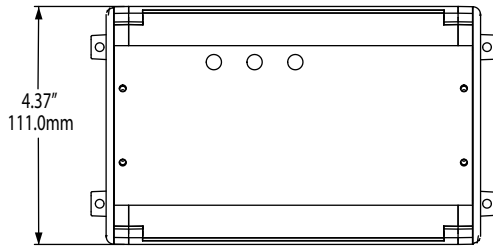

Case Top View

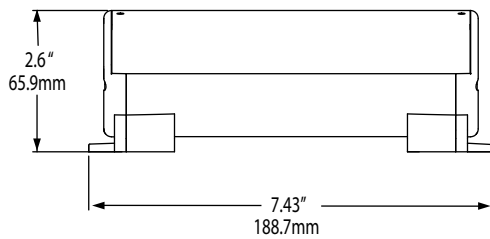

Case Side View

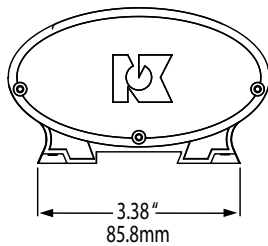

Power Sensing Connections

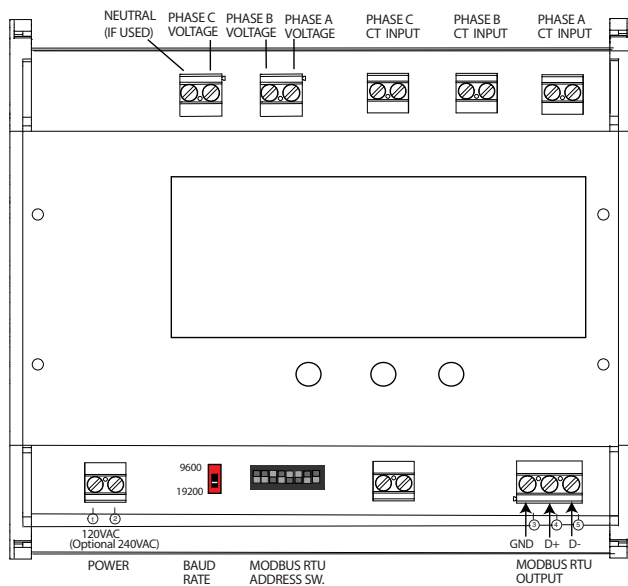

Power Sensing Specifications

Power Supply	• 24 VAC/DC (21–27 V) • 120 VAC (100–125 V) • 240 VAC (200–250 V)
Power Consumption	• 24 VAC/DC: <100 mA • 120 VAC: <50 mA • 240 VAC: <25 mA
Measurement	5A CT input: 3000 A 0.333 mV input: 1500 A
Primary Voltage	100 to 600 VAC
Output	• Modbus RTU - 14 Data Points • Pulsed Contact KWH
Accuracy	<1% FS
Response Time	120 ms
Isolation Voltage	Tested to 4 KV
Frequency Range	50–60 Hz
Case	UL94 V-0 Flammability Rated
Mounting	DIN rail or panel mounting
Environmental	-4 to 122°F (-20 to 50°C) 0–95% RH, non-condensing
Listings	UL/cUL approved

Power Sensing Data Point Table

	Phase A	Phase B	Phase C	Type
Current	●	●	●	RMS
Voltage	●	●	●	RMS
kW	●	●	●	Active
Power Factor	●	●	●	Instantaneous
Power Factor				Average
kWH				Total

Power Sensing Ordering Information

Sample Model Number: APN-600-MV-120-MOD
AC power transducer, 600 VAC maximum input, ProteCT™ current inputs, 120 VAC powered, RS485 **Modbus** output with pulse contact for kWh.



(1) Maximum Primary Voltage

600	600 VAC
-----	---------

(2) Current Input Type

MV	ProteCT™ current transformers, 333 mVAC secondary
5 A	5 A secondary current transformers

(3) Rating Power Supply

24U	24 VAC/DC (100 mA max.)
120	120 VAC (50 mA max.)
240	240 VAC (25 mA max.)

(4) Output Type

MOD	Modbus RTU (RS485), pulse contact for kWh
-----	--

OEMs Test & Evaluation Units for OEMs
Free program expedites evaluation process. See page 3 for details.

APN-R SERIES

Power Monitor

The APN-R Series Power Monitor measures three phases of current and voltage and computes 14 values necessary to track power usage. The monitor uses flexible current sensors to measure the amperes, and the line voltage connects directly to the transducer, up to 600 VAC. The result is 14 data points in the RS485 **Modbus RTU** format. There is also a pulse contact which opens and closes as watt hours are accumulated. The APN-R is factory configured with specifically matched flexible coils. The ease of installation over multiple conductors or bus assemblies will speed installation and produce an accurate set of data to help you identify areas of excessive energy consumption and allow intervention to reduce demand.



Power Sensing Applications

Plant Energy Management

- Measure the power usage of a single piece of equipment, an area of a plant, or the entire facility.

Conveyors

- Detect jams and overloads.
- Check that the belt is loaded properly by measuring the power consumption.

Pump Monitoring

- Detect dry run from clogged, intake, or discharge line.
- Monitor impeller cavitation and bearing wear.

Pump Jam & Suction Loss Protection

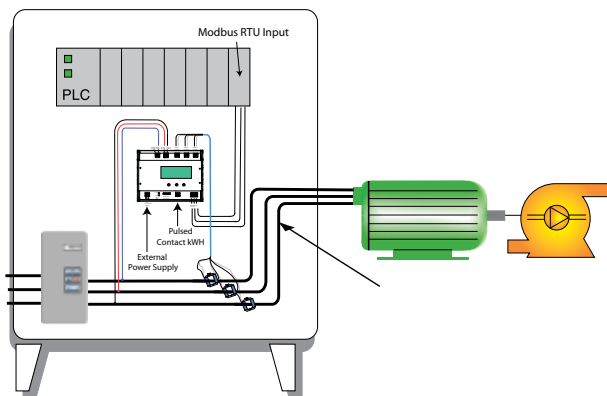

Power Sensing Features

Modbus RTU Output

- RS485 communication protocol reduces the cost involved with proprietary data logging software.
- Compatible with most automation systems.

Externally Powered

- Improves reliability when used in conditions where power interruptions and voltage sags are common.

Compact DIN Rail Mounted Case*

- Clearly labeled terminals provide quick installation.
- Low profile reduces cabinet depth requirements.

LED Displays Network Communication

- Provides quick visual indication that network is operational.

Finger Safe Terminals

- Safe and secure connectors.

UL/cUL Approved

- Accepted worldwide.

*For information on the DIN rail accessories kit, see page 128.

- For additional Application Examples, go to www.nktechnologies.com/applications



Power Sensing Dimensions

Case Side View

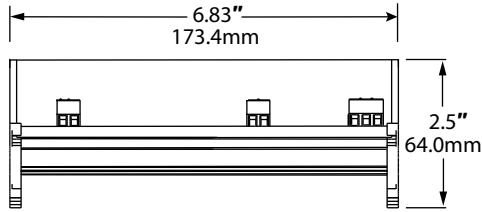

Case Top View

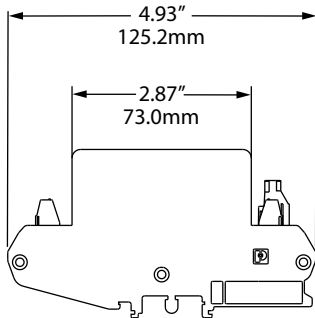

Note: Drawings are not to scale.

Power Sensing Connections

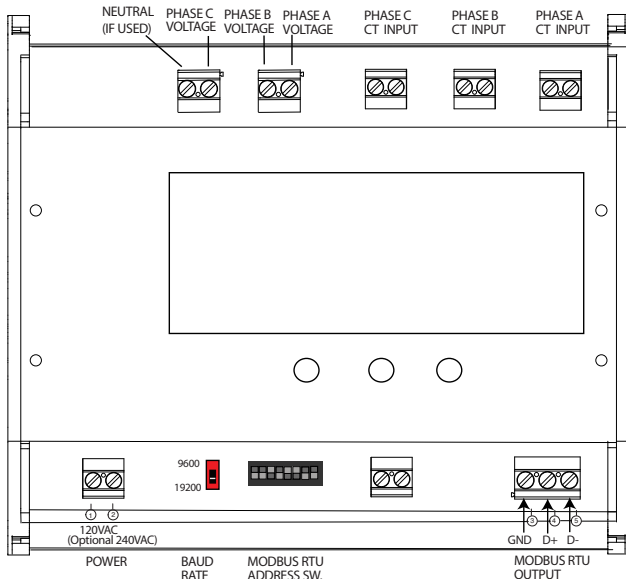

Power Sensing Specifications



Power Supply	<ul style="list-style-type: none"> • 24 VAC/DC (21–27 V) • 120 VAC (100–125 V) • 240 VAC (200–250 V)
Power Consumption	<ul style="list-style-type: none"> • 24 VAC/DC: <100 mA • 120 VAC: <50 mA • 240 VAC: <25 mA
Measurement	2000 A
Primary Voltage	100 to 600 VAC
Output	<ul style="list-style-type: none"> • Modbus RTU - 14 Data Points • Pulsed Contact KWH
Accuracy	<1% (10 – 100% of range)
Response Time	120 ms
Isolation Voltage	Tested to 4 KV
Frequency Range	50/60 Hz
Case	UL94 V-0 Flammability Rated
Mounting	DIN rail or panel mounting
Environmental	-4 to 122°F (-20 to 50°C) 0–95% RH, non-condensing
Listings	UL/cUL approved

Power Sensing Data Point Table

	Phase A	Phase B	Phase C	Type
Current	●	●	●	RMS
Voltage	●	●	●	RMS
kW	●	●	●	Active
Power Factor	●	●	●	Instantaneous
Power Factor				Average
kWH				Total

Power Sensing Ordering Information

Sample Model Number: APN-600-RC1-120-MOD
AC power transducer, 600 VAC maximum input, flexible current inputs (0–500 A range), 120 VAC powered, RS485 **Modbus** output with pulse contact for kWh.



(1) Maximum Primary Voltage

600	600 VAC
-----	---------

(2) Current Input Type

RC1	Flexible coil sensors 0–500 A range
RC2	Flexible coil sensors 0–2000 A range

(3) Rating Power Supply

24U	24 VAC/DC
120	120 VAC
240	240 VAC

(4) Output Type

MOD	Modbus RTU (RS485), pulse contact for kWh
-----	--



Test & Evaluation Units for OEMs

Free program expedites evaluation process. See page 3 for details.



APS SERIES

Power Transducers

APS Series kWh Power Transducers offer an inexpensive way to measure kWh on single- and three-phase balanced loads. The APS Series constantly measures motor power consumption, which is proportional to the amount of work being done and an indication of the motor load. Ideal for mixing, grinding, machining and pumping applications where power measurement is needed, the APS Series includes a CT, voltage sensor and output signal conditioner in a single package designed for easy installation. Available for input currents up to 180 A and voltages up to 600 VAC.



Power Sensing Applications

Grinding and Milling Control

- Measure grinder horsepower; optimize feed rates.

Viscosity Control

- Continuously calculate mixer kW draw; monitor viscosity without entering vessel.

Tool Monitoring and Jam Protection

- Measure drive motor HP to determine tool travel or contact with work.
- Monitor motor horsepower to provide an indication of motor jams.

Crusher/Grinder/Shredder Motor Interlocks

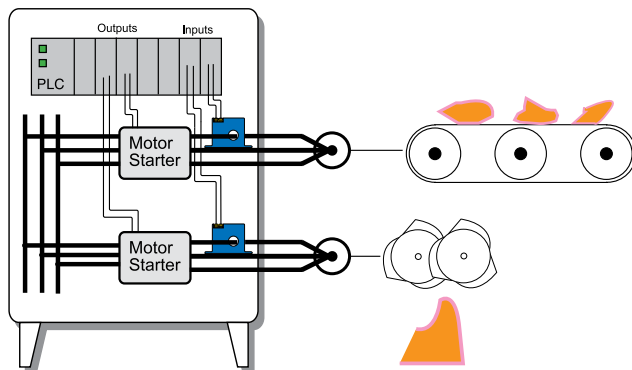

- For additional Application Examples, go to www.nktechnologies.com/applications

Power Sensing Features

True Power Measurement

- Measures true power (HP or kW) on balanced loads; accounts for voltage and power factor fluctuations and improves sensitivity to load changes.
- Requires only one or two power legs for installation.

Fast and Easy Installation

- Current and voltage sensors in one package and 24 VDC loop-powered supply allows for quick and easy two-wire installation.

Factory-calibrated Ranges

- Single range factory calibrated to ensure accuracy.

UL/cUL Approved

- Accepted worldwide.



Power Sensing Dimensions

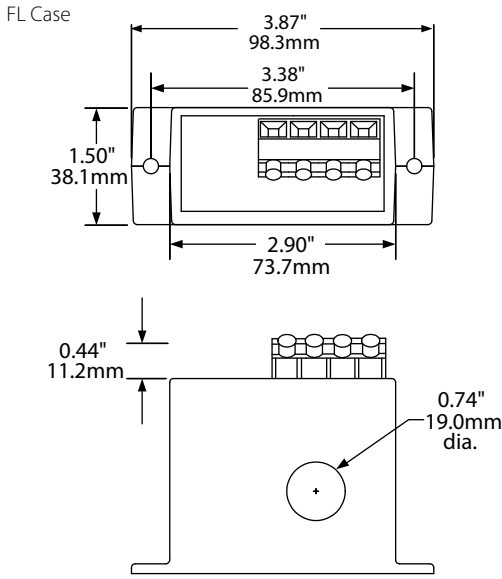

Power Sensing Connections

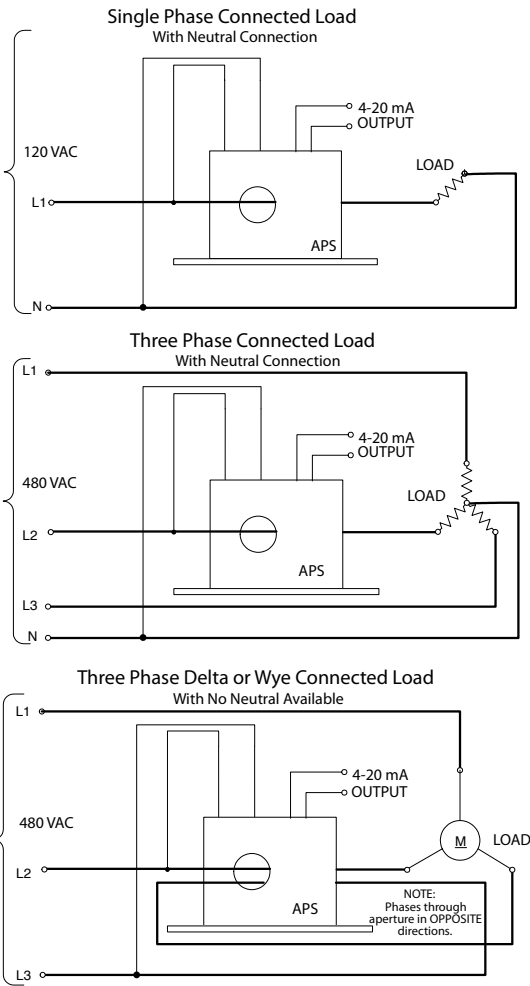

Power Sensing Specifications



Power Supply	24 VDC loop-powered (12–36 V)
Primary Voltage Input	120, 240, 480 or 600 VAC
Output	4–20 mA proportional to max. KW; 25 mA limit
Accuracy	<1% FS
Loading	500 Ω @ 24 VDC
Response Time	100 ms (to 90% of step change)
Isolation Voltage	UL listed to 1270 VAC, tested to 5 KV
Frequency Range	50–60 Hz
Case	UL94 V-0 Flammability Rated
Mounting	Panel mounting
Environmental	-4 to 122°F (-20 to 50°C) 0–95% RH, non-condensing
Listings	UL/cUL (except 600 V models)

Power Sensing Ordering Information

Sample Model Number: APS4-420-24L-10.0

Single phase watt transducer, 10 kW range, 480 VAC input, may be wired with two opposite current wire passes, 4–20 mA output, loop-powered.



(1) Input Voltage

1	120 VAC
2	240 VAC
4	480 VAC
6	600 VAC (not UL listed)

(2) Output Signal

420	4–20 mA
-----	---------

(3) Power Supply

24L	24 VDC loop-powered
-----	---------------------

(4) Input Range

0.5	0.5 KW
0.75	0.75 KW
1.0	1.0 KW
5.0	5.0 KW
10.0	10 KW
20.0	20 KW
50.0	50 KW
75.0	75 KW
100	100 KW

Note: Not all ranges available for every voltage range. Minimum current for stated accuracy is 2 A, maximum current 180 A.



Test & Evaluation Units for OEMs

Free program expedites evaluation process. See page 3 for details.



APT SERIES

Power Transducers

APT Power Transducers measure three phases of current and voltage, and produces an industry standard analog signal proportional to the watts used. The monitor uses current transformers to measure the amperes, and the line voltage connects directly to the transducer, up to 600 VAC. The APT Power Transducer can be configured to accept 5 A secondary current transformers or the safer ProteCT™ low voltage output sensors. Either type of current sensing will produce an accurate output signal to help you identify areas of excessive energy consumption and allow intervention to reduce demand.

Power Sensing Applications

Plant Energy Management

- Measure the power usage of a single piece of equipment, an area of a plant or the entire facility.

Conveyors

- Detects jams and overloads.
- Check that the belt is loaded properly by measuring the power consumption.

Pump Monitoring

- Detect dry run from clogged intact or discharge line.
- Monitor impeller cavitation and bearing wear.

Pump Jam & Suction Loss Protection

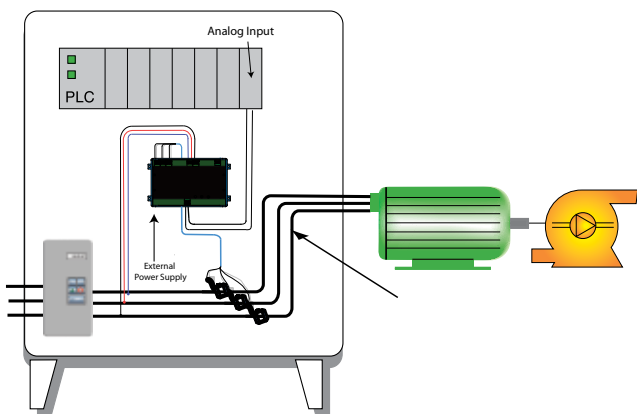

- For additional Application Examples, go to www.nktechnologies.com/applications



APT Power Monitor with Analog Output

Power Sensing Features

Industry Standard Analog Outputs

- Choose 4–20 mA, 0–5 or 0–10 VDC.
- Compatible with most automation systems.

Externally Powered

- Improves reliability when used in conditions where power interruptions and voltage sags are common.

Compact DIN Rail Mounted Case*

- Clearly labeled terminals provide quick installation.
- Low profile reduces cabinet depth requirements.

Finger Safe Terminals

- Safe and secure connectors.

UL/cUL Approved

- Accepted worldwide.

*For information on the DIN rail accessories kit, see page 128.

APT Output Values

APT Power Transducers produce full range output. When the current transformer is producing its maximum signal, the primary voltage is at the range maximum and power factor is at unity. As an example, using the APT-480-5 A-120-420 with 400:5 current transformers, the transducer will produce 20 mA when there is 400 A through the CT and the primary voltage is 480. If the transducer is used to monitor a three-phase circuit using three CTs, 20 mA represents 332,544 watts. The equation for three-phase wattage is voltage times amperage, times the square root of three (1.732) times power factor. If this transducer is used to monitor a three-phase load using two CTs, the transducer will produce 14.67 mA, or the output will represent 2/3 of the actual watts being used under the same conditions: 480 V primary voltage, 400 A through 400:5 CTs and unity power factor.



Power Sensing Dimensions

Case Front View

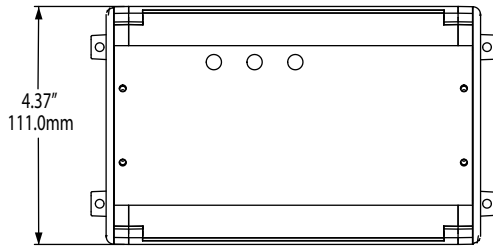

Case Top View

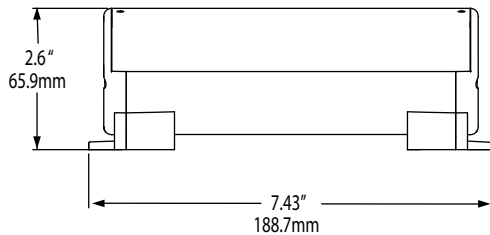

Case Side View

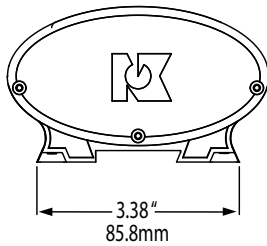

Note: Drawings are not to scale.

Power Sensing Connections

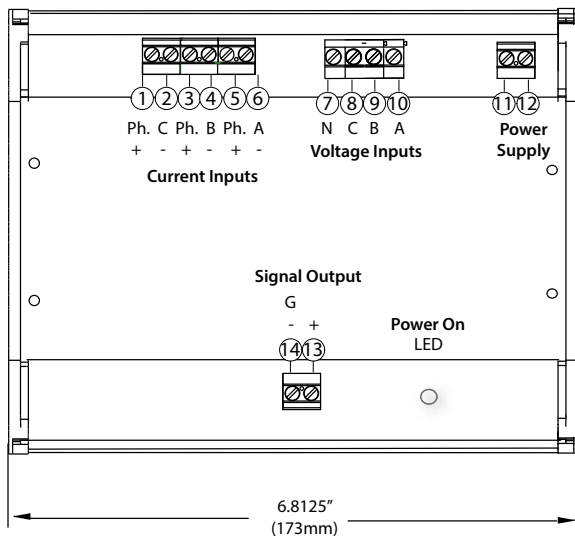

Power Sensing Specifications



Power Supply	• 24 VAC/DC (21–26 V) • 120 VAC (108–132 V) • 240 VAC (216–264 V)
Power Consumption	<2 VA
Primary Voltage Input	120, 240, 480 or 600 VAC
Output	• 4–20 mA current • 0–5 or 0–10 VDC
Accuracy	<0.5% FS
Response Time	120 ms
Isolation Voltage	Tested to 4 KV
Frequency Range	6–100 Hz
Case	UL94 V-0 Flammability Rated
Mounting	DIN rail or panel mounting
Environmental	-4 to 122°F (-20 to 50°C) 0–95% RH, non-condensing
Listings	UL/cUL approved

Power Sensing Ordering Information

Sample Model Number: APT-480-MV-120-420

AC power transducer, 480 VAC input, ProteCT™ current inputs, 120 VAC powered, 4–20 mA output, DIN rail mounting.

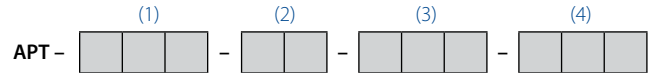

(1) Primary Voltage

120	120 VAC
240	240 VAC
480	480 VAC
600	600 VAC

(2) Current Input Type

MV	ProteCT™ current transformers, 333 mVAC secondary
5 A	5 A secondary current transformers

(3) Power Supply

24U	24 VAC/DC
120	120 VAC
240	240 VAC

(4) Output Type

420	4–20 mA proportional to wattage (see calculation example under APT Output Values)
005	0–5 VDC
010	0–10 VDC



Test & Evaluation Units for OEMs

Free program expedites evaluation process. See page 3 for details.

APT-TH SERIES

Three-hole Power Transducer

The APT-TH Series Power Transducers monitor watt consumption of three phase loads. They provide an analog signal proportional to the active power consumed by the monitored load. The three current carrying conductors pass through the three windows of the top section and the matching voltage input at the terminals. The APT-TH is a one-piece solution for measuring power; no external current transformers are needed and installation is easy. The design of the APT-TH ensures that the monitor is always correctly orientated. If connected improperly by mismatching the current and voltage inputs, or placing a conductor through the sensing window back to front rather than front to back, the LED will change color from green to amber. The LED will also turn amber if the phase A conductor is placed through the phase B sensing window, or if power factor is lower than 0.50.

Power Transducer Applications

Pump Monitoring

- Monitor pumps to detect open intake or outflow lines, cavitation or failing bearings.

Grinding and Milling

- Measure wattage/horsepower to optimize feed rate.
- Detect broken or missing tools or drill bits.
- Detect when the tool contacts the material.

Equipment Monitoring

- Constant output proportional to wattage consumed can be compared with utility bills, providing a cost per hour or cost per operation of a machine or process.



Power Transducer Features

One-piece Solution

- No external current transformers.
- No chance for loose CT secondary provides added safety.

Easy Installation

- Snaps onto DIN rail or can be panel mounted using screws.

Finger Safe Terminals for Safety

LED Indicator

- LED on base shows correct phase relationship match.
- Green for normal operation.
- Orange for incorrect installation.

Three Ample Sensing Windows

- Wire carrying 200 A fits easily.

Designed to meet UL, cUL and CE

- Accepted worldwide.

Power Transducer Connections

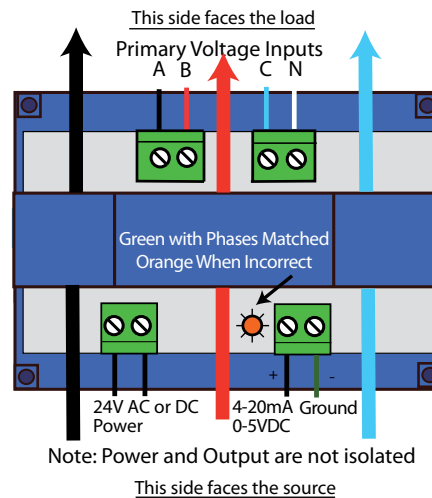

Submersible Pump Application

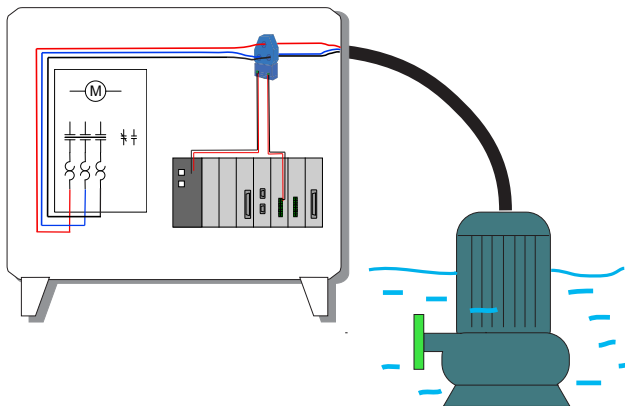

Power Transducer Dimensions

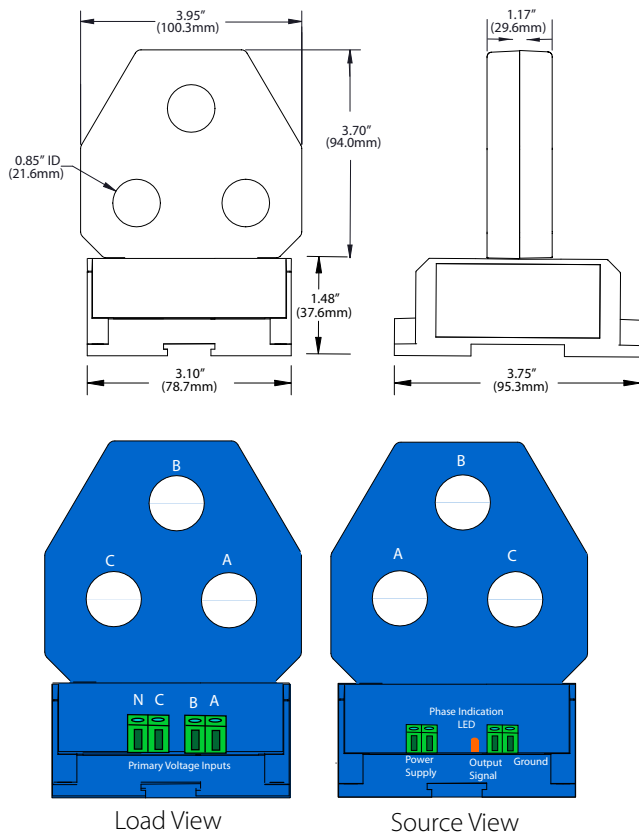

Model Information

	APT1 (208 V)	APT2 (240 V)	APT4 (480 V)	APT6 (600V)
0.5 kW	*	*	NA	NA
0.75 kW	*	*	NA	NA
1.00 kW	*	*	*	NA
2.00 kW	*	*	*	*
5.00 kW	*	*	*	*
7.50 kW	*	*	*	*
10.0 kW	*	*	*	*
15.0 kW	*	*	*	*
20.0 kW	*	*	*	*
40.0 kW	*	*	*	*
50.0 kW	*	*	*	*
60.0 kW	*	*	*	*
75.0 kW	*	*	*	*
100 kW	NA	NA	*	*
150 kW	NA	NA	*	*
200 kW	NA	NA	NA	*

Power Transducer Specifications

Power Supply	24 VAC or DC
Power Consumption	<4 VA
Primary Voltage Input	208, 240, 480, 600 VAC
Output	4–20 mA 0–5 VDC
Response Time	500 ms (10–90% step change)
Accuracy	+/-1% FS
Frequency Range	40–100 Hz
Mounting	DIN rail or panel mounting
Case	UL94 V-0 Flammability Rated
Environmental	-4 to 122°F (-20 to 50°C) 0–95% RH, non-condensing
Listings	Designed to meet UL, cUL and CE

Ordering Information

Sample Model Number: APT1-005-24U-10.0-TH, power transducer, 208 V, three-phase monitored voltage, output 0–5 VDC, 24 VAC/DC powered, 10.0 kW input range, three-hole, solid-core case.

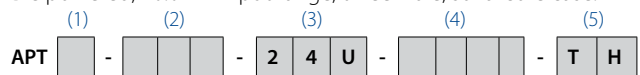

(1) Monitored Voltage

1	208 V three-phase
2	240 V three-phase
4	480 V three-phase
6	600V three-phase

(2) Output Signal

420	4–20 mA
005	0–5 VDC

(3) Power Supply

24U	24 VAC/DC
-----	-----------

(4) Input Range (kW)*

0.50	5.00	20.0	75.0
0.75	7.50	40.0	100
1.00	10.0	50.0	150
2.00	15.0	60.0	200

(5) Case

TH	Three-hole, solid-core
----	------------------------

Note: Note all ranges are available for each primary voltage input range. See Model Information chart.

OEMs Test & Evaluation Units for OEMs
Free program expedites evaluation process. See page 3 for details.

Signal Converters

NK Technologies' ADC series signal converters use sensor outputs (4–20 mA, 0–5 and 0–10 VDC) and convert these to digital RS485 outputs. The CTC series accept either 5 A secondary current from current transformers or 0.333 VAC secondary voltage from our ProteCT™ series sensors and convert them to 4–20 mA loop-powered output for use with PLCs, panel meters or data loggers.

Features:

- DIN rail mounting makes installation a snap
- Industry standard outputs

- **ADC SERIES**
Analog to Digital Converterpage 116
- **CTC SERIES**
Signal Converter.....page 118

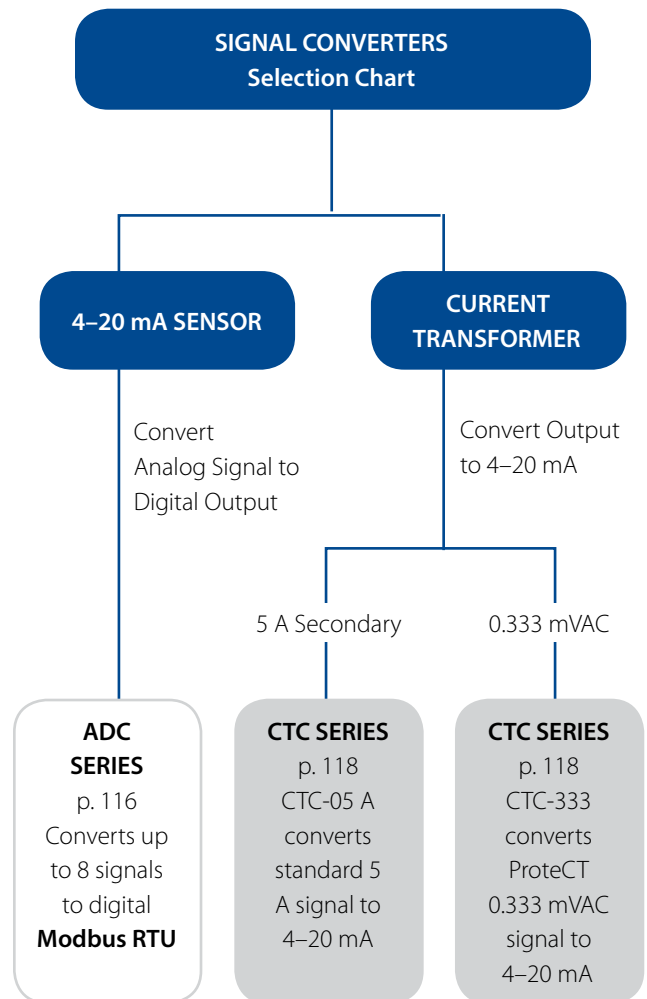

ADC SERIES

Analog to Digital Converters

The ADC Series Signal Converter connects up to eight analog sensors, or up to eight separately powered analog output sensors, or up to four of each. This will produce a digital signal representing 0–100% of each sensor output. It is the perfect solution for photovoltaic power production system monitoring. The ADC converter allows for individually-ranged devices to interface with the industry-standard **Modbus RTU** serial protocol. The device can accept analog signals from current, voltage or temperature sensors, allowing the installer great versatility and higher accuracy. It was designed and built to meet NK Technologies' trusted standards of reliability and ease of use.

Signal Converter Applications

Photovoltaic Power Production

- Measure current output accurately using a sensor sized appropriately.
- Measure current from a panel and after the combiner with the same device.
- Measure voltage output, temperature, or any parameter sensor 4–20 mA, 0–5 VDC or 0–10 VDC output.

Machine Control

- Combine several analog signals into a single **Modbus** address to enable web viewing of data.

SCADA System

- Report and record current, voltage, power, pressure, frequency and flow by using existing sensors but adding network communication easily.

Analog Sensor to Digital Network Conversion

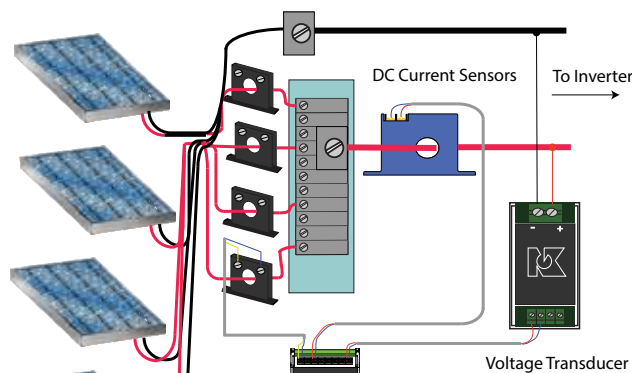

Signal Converter Features

Eight Points of Data

- Convert up to eight analog, sensor outputs using a single network address.
- Sensor loop power is supplied by the converter: No DC power supply is required.
- Models for 8 loop-powered (2-wire) and 8 externally powered (4-wire) or 4 of each type.

Fast and Easy Installation

- DIN rail mounting converter* with finger-safe terminals clearly marked for field installation speed.

Application Versatility

- Convert any standard sensor output to **Modbus RTU** digital network format.

Choice of Power Supplies

- ADC converter can be factory set for 120 VAC, 240 VAC or 24 VDC power supplies.

Communication Baud Rate Choices

- Field-selectable 9600 or 19200 baud rate speeds.

*For information on the DIN rail accessories kit, see page 128.

Use any 4–20 mA, 0–5 VDC or 0–10 VDC output sensor as an input to the NK Technologies' ADC analog-to-**Modbus** converter: Current, voltage, temperature, or any parameter that the application calls for. With the digital **Modbus** output scaled for zero to 100 percent the signal will represent whatever you may need to measure.

- For additional Application Examples, go to www.nktechnologies.com/applications

Signal Converter Dimensions

Side View

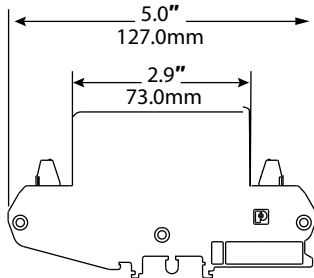

End View

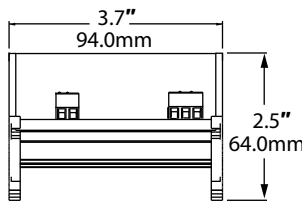

Signal Converter Connections

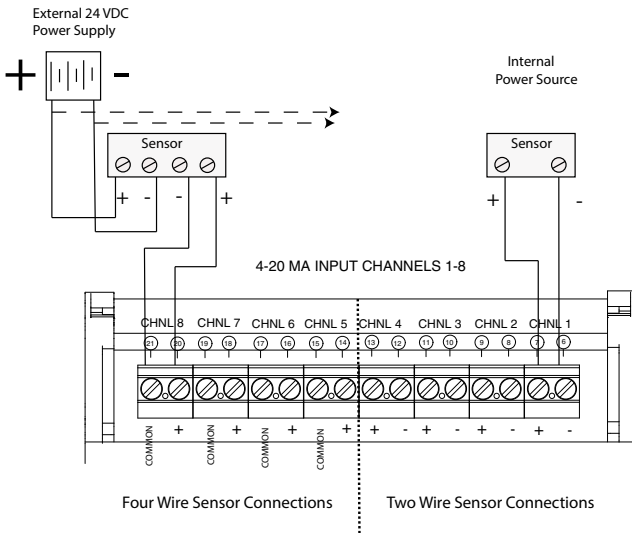

Wiring Notes for Installation:

1. Connect sensors to input channel terminals 6–21.
2. Set **Modbus** network address 1–247.
3. Connect 120 VAC power (240 VAC optional).

Signal Converter Specifications



Power Supply	<ul style="list-style-type: none"> • 120 VAC (108–132 V) • 240 VAC (216–264 V) • 24 VDC (22–26 V)
Power Consumption	<ul style="list-style-type: none"> • 120 VAC: <50 mA • 240 VAC: <25 mA • 24 VDC: <200 mA
Output	Modbus RTU Slave 8 Channels (RS485)
Output Protocol	1 start bit, 8 data bits (LSB first), 1 bit for even parity, 1 stop bit
Output Functions	Function 04, "Read Input Registers"
Output Range	0–120% (4 mA = 0, 20 mA = 100%)
Input Range	<ul style="list-style-type: none"> • 4–20 mA (power from converter or external) • 0–5 VDC (externally powered) • 0–10 VDC (externally powered)
Accuracy	1.0% FS
Indication	Green Power On LED, yellow Busy LED, red Fault LED
Addressing	8 wide binary switch (1 to 247)
Environmental	-4 to 122°F (-20 to 50°C) 0–95% RH, non-condensing
Listings	UL/cUL

Signal Converter Ordering Information

Sample Model Number: ADC1-420-120-MOD-DIN
Eight-channel 4–20 mA input converter, 120 VAC powered.

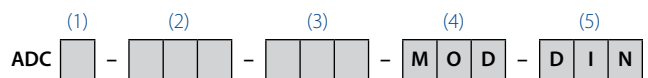

(1) Input channels

1	Eight 4–20 mA loop-powered input channels
2	Four loop-powered, four external powered (4-wire)
3	Eight external-powered inputs

(2) Sensor Input Type

420	4–20 mA inputs
005	0–5 VDC
010	0–10 VDC as inputs available

(4) Output Type

MOD	Modbus RTU
-----	-------------------

(5) Case Style

DIN	DIN rail mounting
-----	-------------------

(3) Power Supply

120	120 VAC
240	240 VAC
24D	24 VDC

Signal Converters

OEMs Test & Evaluation Units for OEMs
Free program expedites evaluation process. See page 3 for details.



CTC SERIES

Signal Converters

CTC Series Signal Converters allow you to use an existing standard 5 A secondary or low-voltage ProteCT™ current transformer over a conductor to produce an industry standard 4–20 mA two-wire, loop-powered signal. The signal is proportional to the current in the primary circuit. The CTC series snaps onto a standard DIN rail. The sensor output is connected to the load (PLC or panel meter, etc.) and a 24 VDC power source, and the current transformer is connected to the input terminals.



Signal Converter Applications

Adding Current Monitoring for System Upgrades

- Measure an entire plant current consumption or individual machine usage.

Detect Problems Before Failure Occur

- Detect bearing failures on drive motors and open discharge lines on pumps.

Tool Monitoring and Jam Protection

- Measure drive motor HP to determine tool travel or contact with work.
- Monitor motor current use to provide an indication of motor jams.
- Use existing current transformers to monitor the current, and transmit 4–20 mA industry standard output.

Signal Converter Features

Uses any Standard 5 A Current Transformer or the Safer ProteCT™ Low Voltage Design

- Produces a 4–20 mA signal proportional to the AC current through the CT based on CT ratio.
- Two wires in, two wires out: Couldn't be easier.

Fast and Easy Installation

- DIN rail mounted* and 24 VDC loop-powered supply allows for quick and easy two-wire installation.

No Calibration Needed

- The primary current transformer ratio provides the scaling required without any other installer intervention.

UL/cUL Approved

- Accepted worldwide.

*For information on the DIN rail accessories kit, see page 128.

Crusher/Grinder/Shredder Motor Interlocks

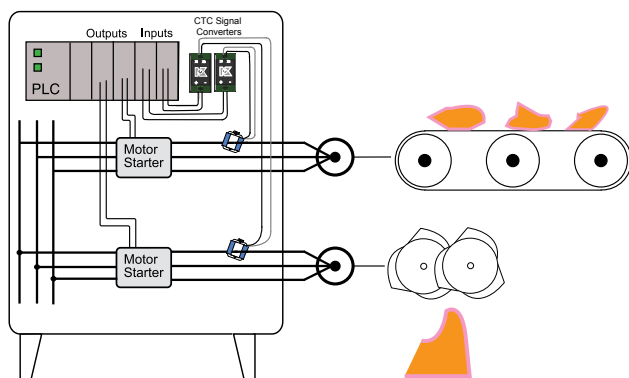

For additional Application Examples, go to www.nktechnologies.com/applications

Signal Converter Dimensions

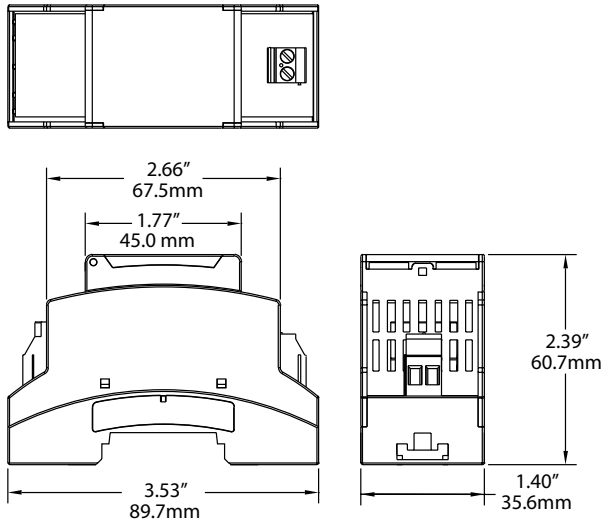

Signal Converter Connections

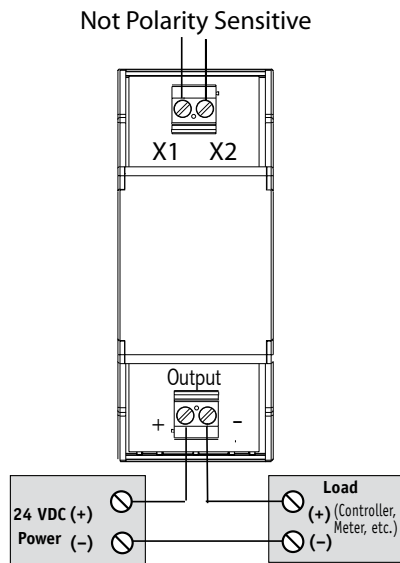

Notes:

With 5 A secondary current transformers, the secondary must be connected to a load (NK Technologies' CTC converter or other load) when energized.

With ProteCT™ type (low voltage output) current sensors, there is no chance that dangerous voltages will result if the secondary is open when there is current through the sensing window.

Signal Converter Specifications



Power Supply	24 VDC loop-powered (12–30 V)
Output	4–20 mA proportional to max. current
Output Impedance	<500Ω
Input Range	Based on current sensor ratio
Input Burden	1.67 VA max. for stated accuracy
Accuracy	1.0% FS
Response Time	100 ms (to 90% step change)
Max. Inrush Current	300% FS (6 sec. duration)
Frequency Range	10–100 Hz
Environmental	-4 to 122°F (-20 to 50°C) 0–95% RH, non-condensing
Listings	UL/cUL

Signal Converter Ordering Information

Sample Model Number: CTC333-420-24L-DIN
 Transducer accepts 333 VAC inputs from ProteCT™ current sensors, and produces a corresponding 4–20 mA signal.



(1) Input CT Type

333	0.333 VAC low voltage ProteCT™
05 A	5 A secondary

(2) Output Signal

420	4–20 mA
-----	---------

(3) Power Supply

24L	24 VDC loop-powered
-----	---------------------

(4) Case Style

DIN	DIN rail mounting
-----	-------------------

OEMs Test & Evaluation Units for OEMs
 Free program expedites evaluation process. See page 3 for details.



Current Transformers

NK Technologies offers current transformers (CTs) for use with power transducers, panel meters, and in two-piece installations, with transducers and switches to extend ranges for high amperage/large conductor applications.

Features:

- 1 A, 5 A or 0–333 mV secondary outputs
- Split-core or solid-core case
- Agency approved
- 5 A secondary ratios available from 50 A to 3000 A and higher

- **CT-MS & CT-LS Series**
1 A & 5 A Secondary Current Transformerspage 121
- **Current Transformers**
5 A Secondary.....page 123
- **CTRC Series**
AC Current Transformer
ProteCT Type 333 mVAC Output.....page 124
- **ProteCT™ Series**
mV Current Transformers.....page 126

CT-MS & CT-LS SERIES

1 A & 5 A Secondary Current Transformers

1 A and 5 A Secondary Current Transformers offer a compact, cost-effective means of measuring primary current. These current transformers provide an easy-to-install method to measure AC current, producing a 0–1 A or 0–5 A output proportional to the current flowing through the sensing window. Both the CT-MS and the CT-LS series offer a larger-than-average sensing window and a split-core design for easy installation.

Current Transformer Features

- Split-core case for convenient installation over large wires or bus bars.
- 1 A and 5 A secondary CTs are compatible with standard power monitors and panel meters designed for 1 A or 5 A input.
- Larger sensing windows:
MS Series aperture measures 2.22" x 1.19" and measures current from 0–150 to 0–800 A.
LS Series aperture measures 3.49" x 2.36" and measures current from 0–800 to 0–1600 A.
- Plated terminals for reliability.
- UR recognized file E475131. Meets ANSI/IEEE C57.13 and IEEE C57.13.2.

Current Transformer Applications

- Serves as current input for use with APT and APN series KW transducers.
- Saves space in control panels by remotely locating the sensing of the current closer to the load.
- The current transformer secondary can be connected to the NK CTC-05A-420-24L-DIN to produce a loop-powered, 4–20 mA signal proportional to the current through the CT.

Power-Pump Load Monitoring

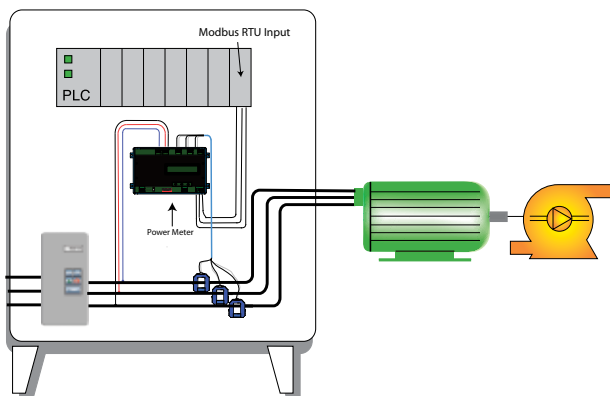

CT-MS Series



CT-LS Series

Connecting a Current Transformer

A current transformer (CT) should never be energized (AC current through the sensing window) without a load connected to the output terminals. Best practice is to terminate the current transformer secondary on a terminal block with the ability to short between two points before extending the leads to the load. If it is ever necessary to remove the load from the CT while it is or could become energized, a shorting bar can be placed between the secondary loads, as shown in the drawing below. This will allow the load to be removed safely.

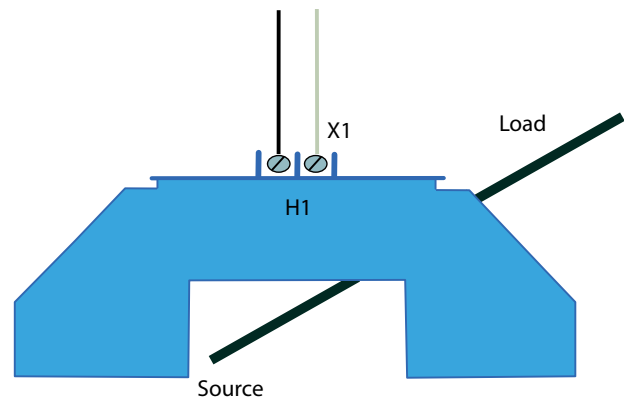

OEMs

Test & Evaluation Units for OEMs

Free program expedites evaluation process. See page 3 for details.



Current Transformer Dimensions

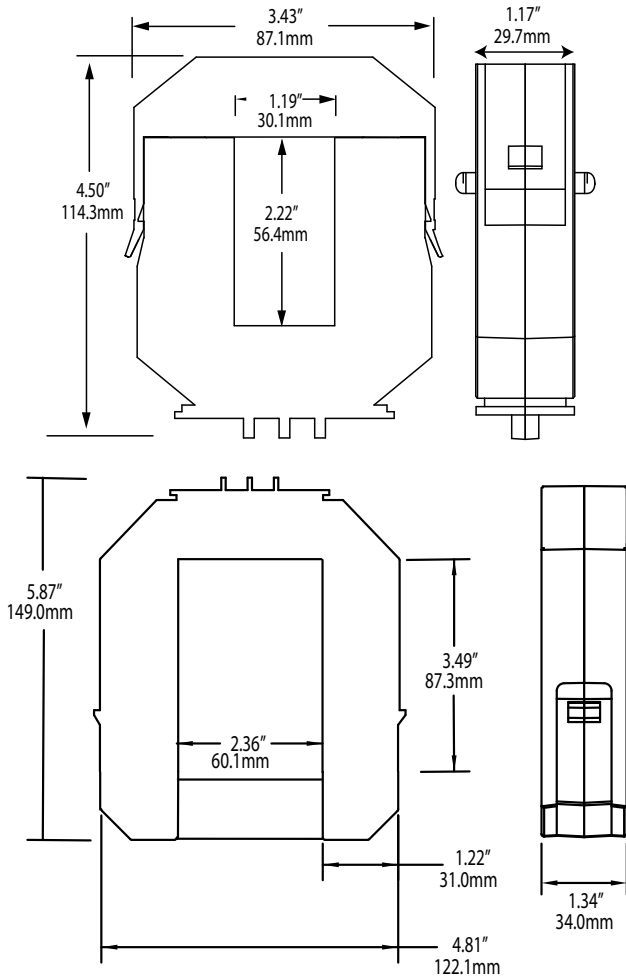

Current Transformer Specifications



Power Supply	None, Self-powered							
Current Range	<ul style="list-style-type: none"> • CT-MS: 0–150 through 0–800 A • CT-LS: 0–800 through 0–1600 A 							
Output Signal	0–1 A or 0–5 A (AC)							
Frequency	50–400 Hz							
Primary Circuit Voltage	600 VAC							
Accuracy	<ul style="list-style-type: none"> • 200–1600 A models: ±1% (10–100% of range) to 50°C • 150 A model: ±1.5% (10–100% of range) to 50°C 							
Linearity	0.5% (10–100% of range)							
Thermal Rating	1.0 @ 30°C							
Listings	UL/cUL Approval							
Weight	CT-MS Series		CT-LS Series					
	150	<0.75 lbs.	800	2.0 lbs.				
	200	<0.75 lbs.	1000	2.2 lbs.				
	300	<0.75 lbs.	1200	2.3 lbs.				
	400	<0.75 lbs.	1400	2.3 lbs.				
	500	<0.75 lbs.	1600	2.4 lbs.				
	600	<0.75 lbs.						
800	<0.75 lbs.							
Allowable Burden	CT-MS Series				CT-LS Series			
	1 A Secondary		5 A Secondary		1 A Secondary		5 A Secondary	
	Ratio	Burden	Ratio	Burden	Ratio	Burden	Ratio	Burden
	150:1	1.0 VA	150:5	1.2 VA	800:1	16.0 VA	800:5	10.0 VA
	200:1	1.0 VA	200:5	1.2 VA	1000:1	16.0 VA	1000:5	10.0 VA
	300:1	1.0 VA	300:5	1.2 VA	1200:1	16.0 VA	1200:5	10.0 VA
	300:5	4.5 VA			1400:1	16.0 VA		
	400:1	1.0 VA	400:5	1.2 VA			1600:5	12.5 VA
	500:1	2.0 VA	500:5	5.0 VA				
	600:1	2.5 VA	600:5	7.5 VA				
800:1	2.0 VA	800:5	7.5 VA					

Current Transformers

Current Transformer Connections

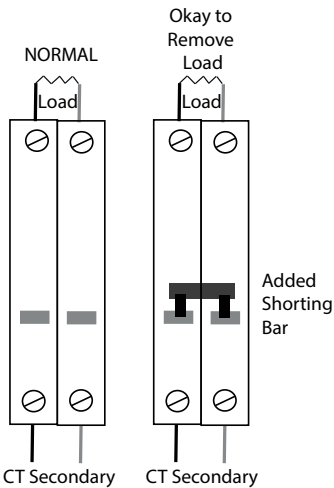

Current Transformer Ordering Information

Sample Model Number: CT-0800-5-LS
 Current transformer with 800:5 ratio allowable burden, 5 A secondary output, and large sensing window.



(1) Model

CT-MS Models	
0150	150 ratio
0200	200 ratio
0300	300 ratio
0400	400 ratio
0500	500 ratio
0600	600 ratio
0800	800 ratio

CT-LS Models	
0800	800 ratio
1000	1000 ratio
1200	1200 ratio
1600	1600 ratio (5 A only)

(2) Output Signal

1	0–1 A secondary
5	0–5 A secondary

(3) Case Style

MS	Medium sensing window
LS	Large sensing window

OEMs Test & Evaluation Units for OEMs
 Free program expedites evaluation process. See page 3 for details.



CURRENT TRANSFORMERS

5 A Secondary

5 A Secondary Current Transformers offer a compact, cost-effective means of measuring primary current and providing 0–5 A secondary output proportional to the primary current being sensed. Available in a solid-core case.

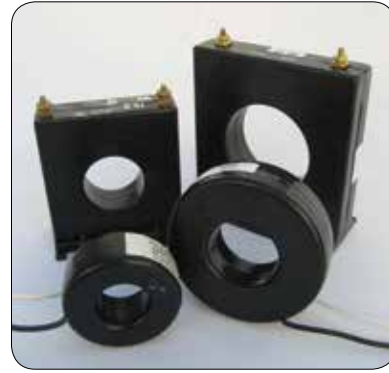

Current Transformer Features

- Solid-core case; choice of round with flying leads or square with terminals and integral feet for panel mounting.
- Aperture diameters from 1.13" to 2.5" ID.
- Agency approved.

Current Transformer Applications

- Serves as current input for use with APT and APN Series KW transducers.
- Save space in control panels by remotely locating CTs closer to load.
- 5 A secondary compatible with standard products offering a 5 A analog input option.
- Broad line accommodates primary currents from 50 A to 1600 A.

Current Transformer Specifications

Power Supply	Self-powered	
Current Range	See Ranges/VA Burdens	
Output Signal	0–5 A (AC)	
Frequency	50–400 Hz	
Insulation Class	0.6 KV BIL, 10 KV full wave	
Accuracy	ANSI rated, (<2.0%)	
Allowable Burden	See Ranges/VA Burdens	
Rating Factor	2.0 @ 30°C amb.	
Aperture Size	Series	Aperture Size
	2	1.13" (28.7 mm)
	5	1.56" (39.6 mm)
	7	2.50" (63.5 mm)

Current Transformer Ranges/VA Burdens (max.)

CT Series			Series Model	CT Ratio:5
2	5	7		
1	0.75	0.5	500	50
1	0.75	0.5	500	50
2	1.25	1	750	75
2.5	2.25	2	101	100
4	5	2.5	151	150
5	5	5	201	200
7.5	10	5	251	250
10	12.5	5	301	300
	12.5	12.5	401	400
	25	15	501	500
	25	25	601	600
	30	35	801	800
	35	35	102	1000
	40	40	122	1200
		50	152	1500
		50	162	1600

Note: For recommended lead length based on allowable burden, see the CT White Paper.

Current Transformer Ordering Information

Sample Model Number: 2RL-501-NK



(1) Series

2, 5, or 7	CT Series
------------	-----------

(2) Case

RL	Round doughnut
----	----------------

SFT	Square, integral mounting feet
-----	--------------------------------

(3) Model

XXX	See Ranges/VA Burdens
-----	-----------------------

OEMs

Test & Evaluation Units for OEMs

Free program expedites evaluation process. See page 3 for details.



CTRC SERIES

AC Current Transformer

ProteCT™ Type 333 mVAC Output

CTRC AC Current Transformers monitor circuits up to 2000 A and produce a safe, low voltage output proportional to the RMS current value. This output is designed as an input to a power monitor or transducer, replicating the AC wave shape with phase angle resolution better than 2 degrees. The flexible coil design allows the sensor to be installed over multiple conductors or bus assemblies easily. The cable requires very little space to fit between adjacent phase conductors. The design eliminates the magnetically permeable core of standard current transformers while providing excellent isolation, sensing only the magnetic field of the phase inside the loop.



Current Transformer Applications

Power Monitoring

- Accurate representation of current without the weight or hazards created by 5 A secondary current transformers.

Individual Machines

- Measure power use for cost allocation.
- Detect voltage sags and spikes.

Monitor Entire Building Power Usage

- Locate unneeded power consumption.

Current Transformer Features

333 mVAC Output

- Specifically designed for connection to power monitors and transducers.
- Safe, with no need for shorting blocks.

24 VAC or DC Powered

- Supply and Output are optically isolated.

Factory Calibrated

- Reduces field calibration errors.
- Coils matched with signal conditioning.

DIN Rail Mounted Case*

- Compact size requiring very little panel space.
- Simple snap fit to standard rails.

UL/cUL Approved

- Accepted worldwide.

*For information on the DIN rail accessories kit, see page 128.

Monitoring Power Usage of a Motor Driven Pump

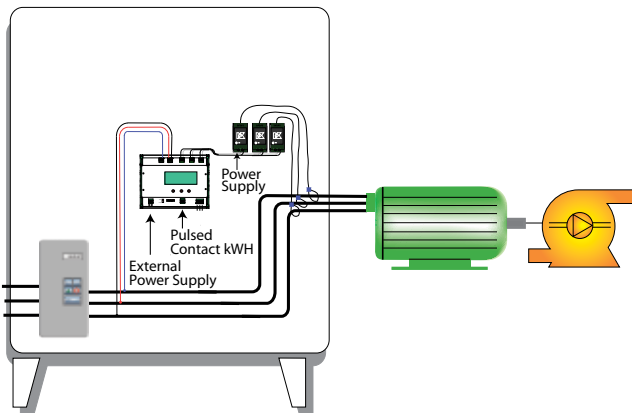

- For additional Application Examples, go to www.nktechnologies.com/applications

OEMs Test & Evaluation Units for OEMs
Free program expedites evaluation process. See page 3 for details.



AC Current Transducer Dimensions

Base

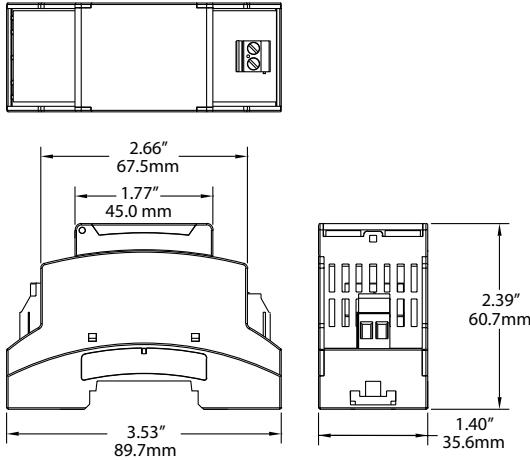

Coil

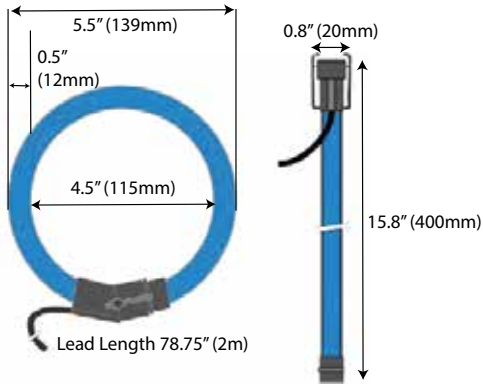

Current Transformer Connections

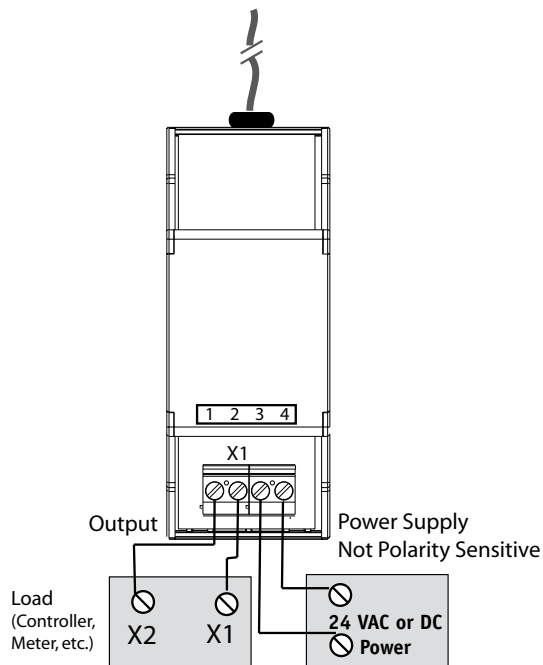

Current Transformer Specifications

Power Supply	24 VAC/DC (12–36 V)
Power Consumption	<2 VA
Output	333 mVAC
Response Time	2 ms
Range	<ul style="list-style-type: none"> • 0–300 • 0–500 • 0–1000 • 0–1500 • 0–2000
Accuracy	±1% FS
Isolation Voltage	Designed for UL 508 1270 VAC, tested to 5000 VAC
Frequency Range	40–400 Hz
Sensing Aperture	4.25" (115 mm) ID
Case	UL94 V-0 Flammability Rated
Environmental	-4 to 122°F (-20 to 50°C) 0–95% RH, non-condensing
Listings	UL/cUL, Designed for CE approval

Current Transformer Ordering Information

Sample Model Number: CTRC-333-500-24U-D
Flexible loop current sensor, 0–500 A AC produces 0–333 mVAC, DIN rail mounting case.

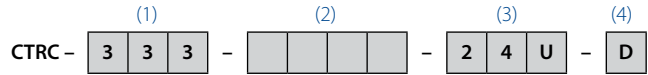

(1) Output Type

333	333 mVAC
-----	----------

(2) Full Scale Range

300	300 A AC
500	500 A AC
1000	1000 A AC
1500	1500 A AC
2000	2000 A AC

(3) Power Supply

24U	24 VAC or DC
-----	--------------

(4) Case Style

D	DIN rail mounting
---	-------------------

Current Transformers



ProteCT™ SERIES

mV Current Transformers

ProteCT™ Series Current Transformers are intended for use with APT and APN Series power transducers. ProtectCT™ low voltage output current transformers provide easy sensing of current on three-phase applications with the added safety of a 333 mV output secondary. Available in split-core case as standard.

Current Transformer Applications

- Tailored for use with AP Series AutoPhase KW/KWH transducers.
- Self-powered design works well in data logger applications.
- Excellent response time for power monitoring applications.

Current Transformer Features

0.333 VAC Output Secondary

- Unique low voltage output allows safe opening of transformer secondary, protecting installers from shock hazards found on traditional 5 A CTs.

Eliminates Need for “Shorting Blocks”

Standard Split-core Case Design

- Snap-close case speeds installation and eases retrofits for existing jobs.
- Eliminates need to power down or disconnect system to install CT, maximizing up time.

High-Impact, UL94 V-0 Rated Polymer Housing

- No exposed metal parts on assembled ProteCT™ devices.

Choose From Three ID's: 0.85", 1.25", 2.0"

Monitor Watts Used by a Pump

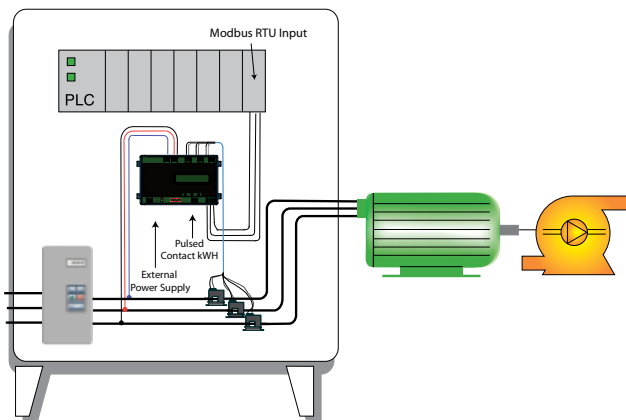

- For additional Application Examples, go to www.nktechnologies.com/applications

OEMs Test & Evaluation Units for OEMs
Free program expedites evaluation process. See page 3 for details.



Current Transformer Dimensions

in (mm)	NKP-075-xxx	CTP-125-xxx-SP	CTP-200-xxx-SP
Width	2.25 (57.2)	3.25 (82.55)	4.75 (120.65)
Height	2.40 (61.0)	3.35 (85.09)	5.00 (122.5)
Depth	1.18 (30.0)	1.00 (25.4)	1.20 (30.48)
Window	0.85 (22.0)	1.25 (31.75)	2.00 (50.80)

Current Transformer Specifications

Power Required	None, self-powered
Accuracy	±1% NKP, ±2% CTP models
Output	0–0.333 VAC
Phase Angle	<1 degree, 2 degrees @ 50% range
Response Time	<1 ms
Isolation Voltage	600 VAC
Max. Primary Voltage	5000 VAC (insulated conductor)
Max. Inrush Current	300% FS (6 sec. duration)
Environmental	-4 to 122°F (-20 to 50°C) 0–95% RH, non-condensing

Current Transformer Ordering Information

Model	Input Range	1.25" (31.75 mm) Window	
0.85" (22 mm) Window		CTP-125-101-SP	0–100 A
NKP-075-005SP	0–5 A	CTP-125-151-SP	0–150 A
NKP-075-015SP	0–15 A	CTP-125-201-SP	0–200 A
NKP-075-030SP	0–30 A	CTP-125-251-SP	0–250 A
NKP-075-050SP	0–50 A	CTP-125-301-SP	0–300 A
NKP-075-070SP	0–70 A	CTP-125-401-SP	0–400 A
NKP-075-101SP	0–100 A	CTP-125-601-SP	0–600 A
NKP-075-151SP	0–150 A	2.0" (50.8 mm) Window	
NKP-075-201SP	0–200 A	CTP-200-601-SP	0–600 A
		CTP-200-801-SP	0–800 A
		CTP-200-102-SP	0–1000 A
		CTP-200-122-SP	0–1200 A
		CTP-200-152-SP	0–1500 A

AMPFlasher™ ACI SERIES

AC Current Indicators

The AMPFlasher™ ACI Series Current Indicator is a compact, inexpensive, easy-to-use LED ring which slips onto a conductor to give a flashing indication of current flow. Ideal for use in control panels, or wherever confirmation of current flow is desired. AMPFlasher™ current indicators are a cost-effective way to detect live conductors and see current flow to fans, heaters, pumps, lighting or other powered devices.

AC Current Indicator Applications

- Quick visual status of electric motor load.
- Identify open heater circuit connection.
- Provide panel mounted indication of current draw on monitored load.
- Confirmation of operation for critical lighting or equipment.

AC Current Indicator Features

Low Sensitivity Turn-on Point

- Detect currents as low as 0.5 A with a single conductor pass, eliminates the need to wrap conductors through multiple times to increase sensitivity.

High Visibility Flashing LED

- Flashing LEDs perform better in daylight conditions and from multiple angles than constant on LEDs.

Choice of Outputs

- LED output standard, optional LED on 24" pigtailed for remote indication.

AC Current Indicator Specifications



Output/Indication	<ul style="list-style-type: none"> • Standard: LED (flashing, red) • Optional: 24" Pigtailed for Remote LED
Indicating Range	0.5 A–100 A
LED On	<500 mA (factory set)
Maximum Primary Circuit Voltage	300 VAC
Dimensions	<ul style="list-style-type: none"> • Overall: 1.15"W x 0.55"D x 1.30"H (29.2 mm W x 14.0 mm D x 33.0 mm H) • Aperture: 0.30" (7.6 mm) ID • Pigtailed: 24" (609.6 mm)
Case	UL94 V-0 Flammability Rated
Mounting	Slides directly onto monitored conductor
Environmental	-4 to 122°F (-20 to 50°C) 0–95% RH, non-condensing
Frequency Response	50–400 Hz
Listings/Certifications	UL/cUL



AC Current Indicator Dimensions

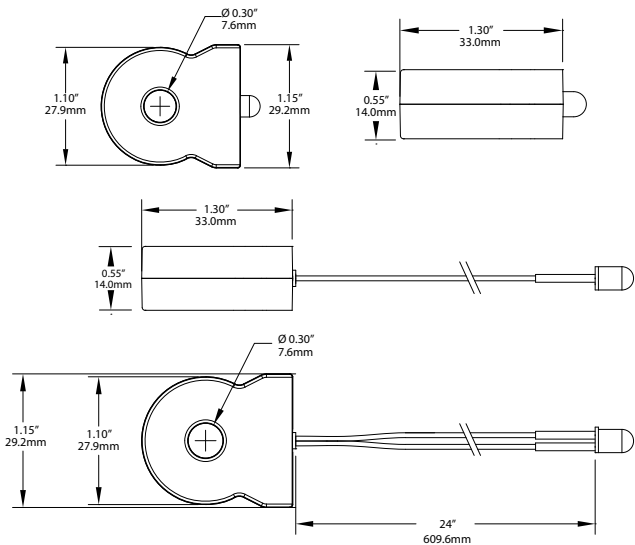

Note: Panel opening should be 0.267 to 0.273", panel thickness 0.32 to 0.125"

AC Current Indicator Ordering Information

Sample Model Number: ACI-0.5-L.
Current Indicator with 0.5 A sensitivity and red flashing LED.

ACI - (1) 0 . 5 - (2)

(1) Sensitivity Level

0.5	500 mA
-----	--------

(2) Indication/Output

L	LED (flashing, red)
P	24" Pigtailed for remote LED



DIN RAIL KITS

DIN Kit or DIN-2 Adapter Kit

DIN Rail Kits provide a convenient method to facilitate the mounting of the ADC, AGL, APN, APT, CTC, VTD, and VTR Series of NK Technologies' sensors. The kits can also be used to mount other products to a panel as needed.

DIN Rail Kit Features

DIN Rail Kit

- Includes two end stops and a bichromated galvanized steel rail.
- High mechanical strength and corrosion resistance.
- Slotted design allows for attachment to most suitable surfaces.
- Rail can be cut in field to desired length.



DIN-2 Adapter Kit

- Includes two plastic brackets and attachment screw to mount the sensor to the rail.
- Compatible with "top hat" or "G" type rail.

"Top Hat" type rail.



"G" type rail.



VTR Voltage Transducer

AGL Ground Fault Sensor



DIN Rail Kit Specifications

DIN Rail Kit

Rail Material	Rail is galvanized steel; 35 mm x 7.5 mm x 175 mm
Rating	Conforms to EN50035, 50022, DIN 46277

DIN-2 Adapter Kit

Rail Compatibility	"Top Hat" Type: 35 x 15 mm, 35 x 7.5 mm "G" Type 32 x 15 mm
Bracket Material	UL 94-V2 Rated Thermoplastic
Temp Range	-40 to 212°F (-40 to 100°C)

DIN Rail Kit Ordering Information

Part Number for DIN Rail Kit: DINKIT

Part Number for DIN-2 Adapter Kit: DIN-2

OEMs Test & Evaluation Units for OEMs
Free program expedites evaluation process. See page 3 for details.

INDEX BY NAME

ADC SERIES	116	ASM SERIES	16	CT-MS & CT-LS SERIES.....	121
AG SERIES	82	ASX SERIES	24	CTC SERIES	118
AGL SERIES	86	ASXP SERIES	28	CTRC SERIES	124
AGLD SERIES	89	ASP-FD SERIES	26	CURRENT TRANSFORMERS.....	123
AGT SERIES	91	ASXP-LS SERIES	32	DG SERIES	92A
AMPFLASHER™		ASXP-MS SERIES	30	DIN RAIL KITS.....	128
ACI SERIES	127	AT SERIES	40	DLT SERIES	78
APN SERIES	105	AT/ATR-FD SERIES	44	DS1 SERIES	34
APN-R SERIES	107	AT/ATR-FL SERIES	46	DS3 SERIES	36
APS SERIES	109	AT/ATR-LS SERIES	50	DT SERIES, 3-WIRE	72
APT SERIES	111	AT/ATR-MS SERIES	48	DT SERIES, 4-WIRE	69
APT-TH SERIES	113	ATCR SERIES	52	DT SERIES, LARGE APERTURE	76
AS0 SERIES	22	ATH SERIES	60	DT SERIES, TEMPERATURE COMPENSATED	74
AS1 SERIES	6	ATP SERIES	54	PROTECT™ SERIES	126
AS1 SERIES COMPACT CASE	13	ATP/ATPR-FL SERIES	58	VTD SERIES	96
AS1 NOR-FT-GO SERIES	8	ATPR VOLTAGE OUTPUT SERIES	56	VTD-BD SERIES	98
AS3 SERIES	10	ATQ SERIES	62	VTR SERIES	94
ASC SERIES	18	ATR SERIES	42	VTU-DIN SERIES	102
ASD SERIES	20	ATS SERIES DIGITAL	64	VTU SERIES	100
ASL SERIES	14	ATS SERIES ROTARY	66		



INDEX BY PRODUCT

Current Sensing Switches4

AS1 SERIES	6
AS1 NOR-FT-GO SERIES	8
AS3 SERIES	10
AS1 SERIES COMPACT CASE	13
ASL SERIES	14
ASM SERIES	16
ASC SERIES	18
ASD SERIES	20
AS0 SERIES	22
ASX SERIES	24
ASP-FD SERIES	26
ASXP SERIES	28
ASXP-MS SERIES	30
ASXP-LS SERIES	32
DS1 SERIES	34
DS3 SERIES	36

AC Current Transducers38

AT SERIES	40
ATR SERIES	42
AT/ATR-FD SERIES	44
AT/ATR-FL SERIES	46
AT/ATR-MS SERIES	48
AT/ATR-LS SERIES	50
ATCR SERIES	52

ATP SERIES	54
ATPR VOLTAGE OUTPUT SERIES	56
ATP/ATPR-FL SERIES	58
ATH SERIES	60
ATQ SERIES	62
ATS SERIES WITH DIGITAL DISPLAY.....	64
ATS SERIES WITH ROTARY DISPLAY.....	66

DC Current Transducers.....68

DT SERIES, 4-WIRE	69
DT SERIES, 3-WIRE	72
DT SERIES, TEMPERATURE COMPENSATED	74
DT SERIES, LARGE APERTURE	76
DLT SERIES	78

Ground Fault Protection80

AG SERIES	82
AGL SERIES	86
AGLD SERIES	89
AGT SERIES	91
DG SERIES	92A

Voltage Transducers.....93

VTR SERIES	94
------------------	----

VTD SERIES	96
VTD-BD SERIES	98
VTU SERIES	100
VTU-DIN SERIES	102

Power Sensing Products.. 104

APN SERIES	105
APN-R SERIES	107
APS SERIES	109
APT SERIES	111
APT-TH SERIES	113

Signal Converters 115

ADC SERIES	116
CTC SERIES	118

Current Transformers 120

CT-MS & CT-LS SERIES.....	121
CURRENT TRANSFORMERS.....	123
CTRC SERIES	124
PROTECT™ SERIES	126

AMPFlasher..... 127

AMPFLASHER™ ACI SERIES	127
---------------------------------	-----

Accessories..... 128

DIN RAIL KITS.....	128
--------------------	-----

RoHS 2 CERTIFICATION OF COMPLIANCE

European Directive 2011/65/EU on the Restriction of Hazardous Substances

The European Community (EC) directive 2002/95/EC, also known as the RoHS 2 Directive, restricts the use of hazardous substances listed below in the manufacture and sale of electrical and electronic equipment.

Based on the information provided to us by the suppliers of raw materials used in the manufacture and delivery of our products and services, NK Technologies maintains a list of specific model numbers and product families designated as RoHS 2 Compliant for orders placed on or after October 1, 2006.

RoHS 2 Compliance shall be taken to mean that,

- With regard to existing designs, RoHS 2 certified substitutions for all materials and components have been specified.
- Components used in the production of compliant parts are certified RoHS 2 compliant and our suppliers have confirmed this compliance status.
- Soldering operations involved in the production of compliant products are performed using lead-free solder.
- Products bear an RoHS 2 compliance logo indicating their status.

Additionally, RoHS 2 Compliance production safeguards assume,

- Where appropriate, process reviews have been performed to ensure the absence of restricted substances.
- Compliant components and materials are segregated from non-compliant components and materials while in inventory.

For purposes of RoHS 2 certification, any Product/Model Number so designated shall contain less than the concentration value of restricted substances by weight in homogenous materials specified as follows:

- Lead0.1%
- Mercury0.1%
- Hexavalent Chromium.....0.1%
- Polybrominated Biphenyls0.1%
- Polybrominated Diphenyl Ethers0.1%
- Cadmium0.01%



2011/65/E

Please contact our factory for information regarding the RoHS 2 compliance status of any NK Technologies product and/or to obtain specific RoHS 2 Compliance Certificates.

ISO 9001 AND ISO 14001 REGISTRATIONS

NK Technologies' commitment to quality and the environment goes beyond compliance to international standards. We have developed and implemented an integrated quality and environmental management system to ensure our business and manufacturing processes provide customer confidence and satisfaction while being good stewards of our environment.

The foundation of our consolidated system is based on the ISO 9001 and ISO 14001 standards. However we go above and beyond basic compliance to continuously improve all of our quality and environmental related operations. Our unwavering goal is to always achieve customer satisfaction with everything we do.

As an ISO registered organization our customers can buy with confidence knowing that NK Technologies designs and manufactures its products within a formal quality assurance system periodically audited by an independent third party auditor. Engaging an appropriately ANAB accredited auditor ensures we do not deviate from documented procedures that provide objective evidence of compliance to the ISO standards.



Please visit our website for more information about our Quality Standards and our ISO 9001 Certification:
www.nktechnologies.com/quality-policy.html

TERMS AND CONDITIONS OF SALE

1. Price and Delivery

All prices are FOB shipping point or our factory, San Jose, CA. Delivery shall be established by mutual agreement and/or defined as acknowledged by NK Technologies. All orders are subject to a \$100 minimum order total. Drop shipments are done on an as needed basis and may incur an additional handling charge.

2. Shipping and Risk of Loss

NK Technologies shall package products for normal shipping considerations. Further NK Technologies may arrange and prepay all transportation charges with the understanding that all costs associated with the delivery beyond the FOB point will be billed to and assumed by the purchaser. All risk of loss or damage to the products pass to the buyer upon delivery to the carrier at the FOB point; the carrier acting as the buyer's agent. No third party freight billing can be permitted.

3. Terms of Payment

Payment shall be made in full within thirty (30) days from the date of product shipment. NK Technologies reserves the right to require full or partial payment in advance of shipment or otherwise change payment terms.

4. Title

Title to the products will pass to the buyer upon delivery to the carrier at the FOB point; provided however, NK Technologies will retain a purchase money security interest in each product until all of its claims arising out of the furnishing of such products have been satisfied in full.

5. Warranty

NK Technologies warrants that all NK Technologies' manufactured products will be free from defects in material and workmanship for the period of five (5) years after receipt by the buyer unless otherwise stated in the product literature. This warranty does not apply to any products or parts not manufactured by NK Technologies; however NK Technologies does agree to assign and transfer to the buyer, insofar as it is permitted by contract or by law, the manufacturer's warranty pertaining to any such products. If any product fails to conform to the warranty applicable to such product, NK Technologies' sole and exclusive liability shall be, at its option, to repair, replace or credit the purchaser's account with an amount equal to the price paid for such products which are returned by the purchaser during the acceptable warranty period with such products' manufacturing date code intact.

THE FOREGOING WARRANTIES ARE IN LIEU OF ALL OTHER WARRANTIES, EXPRESS OR IMPLIED, INCLUDING WITHOUT LIMITATION, ANY WARRANTIES OF MERCHANTABILITY OR FITNESS FOR A PARTICULAR PURPOSE. ALL WARRANTIES (OTHER THAN THOSE EXPRESSLY SET FORTH ABOVE) ARE HEREBY DISCLAIMED AND EXCLUDED BY NK TECHNOLOGIES. NK TECHNOLOGIES NEITHER ASSUMES NOR AUTHORIZES ANY PERSON TO ASSUME ANY OTHER LIABILITIES IN CONNECTION WITH THE SALE OR USE OF ANY PRODUCTS.

6. Returns

Unless agreed to in advance by NK Technologies, all sales are considered final and all merchandise shall be considered the property of the purchaser. At its discretion, NK Technologies may allow for the return of product purchased within the last 180 days in exchange for a restocking charge of twenty-five (25) percent and/or an offsetting order for a value amount equal to or exceeding that of the product returned. Returns of product categorized as "N-R", non-returnable is prohibited. Any merchandise, warranty or other type of product return shall require a Return Material Authorization (RMA) issued by authorized NK Technologies' factory personnel. Unless agreed to in advance by NK Technologies, all products returned shall be shipped at the expense of the purchaser.



For the most current
and up-to-date information...

www.nktechnologies.com

- Up-to-date Product Information
- Data Sheets & Instruction Sheets
- CAD Drawings
- Product Certifications
- Request for Quote
- Support
- Application Examples
- Engineering Resource Articles
- Sign up for Product Updates
- Distributor Information
- ... and so much more!



Visit our website for all the technical,
application and support information that you
could ever want or need!



3511 Charter Park Drive • San Jose, CA 95136
800.959.4014 • sales@nktechnologies.com
www.nktechnologies.com

For expert technical help, contact your local Authorized Representative or
Authorized Distributor.

